

**:seating**  
SOLUTIONS

alea

catalogue

# table of contents

02  
Task

32  
Managerial

56  
Executive

82  
Visitor

92  
Hybrid

100  
Community

# task

**Le sedute “task” o operative assicurano i massimi livelli di durevolezza ed ergonomicità. Comode, funzionali e dallo stile essenziale, queste sono pensate per tutte le figure operative che spendono la maggior parte della loro giornata alla scrivania.**

**Queste sedie sono progettate per garantire una corretta postura del corpo, grazie all’ausilio di supporti lombari e schienali regolabili. Alla postazione di lavoro assicurano stabilità e piena sicurezza.**

“Task” chairs ensure the highest levels of durability and ergonomics. Comfortable, functional and with an essential design, they are intended for professionals who spend most of their day at the desk.

These chairs are designed to ensure correct body posture with the aid of lumbar supports and heightadjustable backrests. They provide stability and complete safety at work.

Les assises “task” ou opérationnelles garantissent les plus hauts niveaux de durabilité et d’ergonomie. Confortables, fonctionnels et au design essentiel, ils sont destinés aux professionnels qui passent la majeure partie de leur journée au bureau.

Ces chaises sont conçues pour assurer une posture correcte du corps grâce à des supports lombaires et des dossiers réglables en hauteur. Au poste de travail assure la stabilité et la sécurité totale.

Las sillas “task” o de trabajo garantizan los más altos niveles de durabilidad y ergonomía. Cómodas, funcionales y con un diseño esencial, están pensadas para los profesionales que pasan la mayor parte del día en el escritorio.

Estas sillas están diseñadas para garantizar una postura corporal correcta con la ayuda de soportes lumbares y respaldos regulables en altura. Garantizan estabilidad y total seguridad en el puesto de trabajo.

04  
T10

10  
T30

16  
T35

20  
T50

26  
T70

# T10



**T10 è una sedia operativa caratterizzata da linee semplici e pulite, perfetta per un utilizzo intensivo e professionale.**

T10 is a task chair with clean and essential lines, perfect for intensive and professional use.

T10 est une chaise opérative caractérisée par des lignes simples et propres, parfaite pour usage intensif et professionnel.

T10 es una silla de trabajo caracterizada por líneas simples y limpias, perfecta para un uso intensivo y profesional.

Il comodo schienale  
in rete presenta  
un supporto lombare  
regolabile di  
colore nero.



The comfortable mesh  
backrest is fitted with an  
adjustable black  
lumbar support.

Le dossier en maille  
confortable est équipé  
d'un support lombaire  
noir réglable.

El cómodo respaldo de  
malla está provisto  
de un soporte lumbar  
negro ajustable.

## Varianti | Variants | Variantes | Variantes

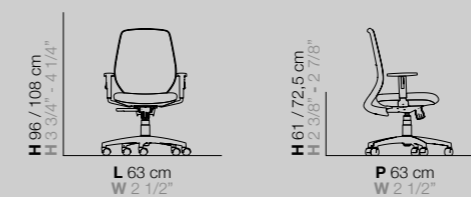

## Finiture | Finishes | Finitions | Acabados

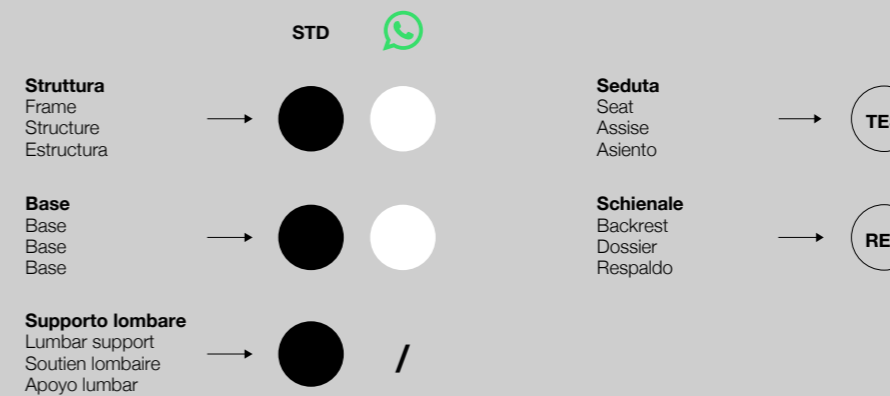

## Mix & match



# T30



**T30 è una sedia operativa che fa della comodità ed dell'ergonomicità i suoi punti di forza. Ideale per un uso quotidiano e prolungato grazie alle numerose possibilità di declinazione disponibili.**

T30 is a task chair that makes comfort and ergonomics its strengths. It is ideal for daily and extended use, thanks to the various declinations available.

T30 est une chaise opérative qui fait du confort et de l'ergonomie sa force. Elle est idéale pour une utilisation quotidienne et prolongée grâce aux plusieurs possibilités de déclinaison.

T30 es una silla de trabajo cuyos puntos fuertes son comodidad y manejo ergonómico. Ideal para el utilizo diario y prolongado, gracias a las numerosas posibilidades de uso.

Lo schienale può essere in rete o rivestito in tessuto, è regolabile in altezza e include un supporto lombare.



The backrest is available in mesh or fabric, is adjustable in height and can be fitted with a lumbar support.

Le dossier est conçu en résille ou en tissu, il est réglable en hauteur et il est équipé d'un support lombaire.

El respaldo, que puede ser en malla o tapizado, es ajustable en altura y cuenta con un apoyo lumbar.



## Varianti | Variants | Variantes | Variantes

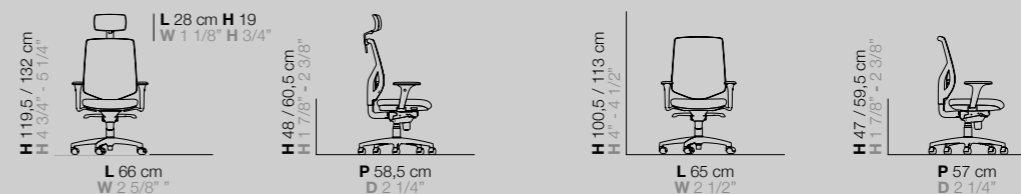

## Finiture | Finishes | Finitions | Acabados

	STD			
<b>Struttura</b> Frame Structure Estructura	→			
<b>Base</b> Base Base Base	→			
<b>Supporto lombare</b> Lumbar support Soutien lombaire Apoyo lumbar	→			
				<b>Seduta</b> Seat Assise Asiento
				→
				<b>Schienale</b> Backrest Dossier Respaldo
				→
				<b>Poggiatesta</b> Headrest Appui-tête Reposacabezas
				→

## Mix & match

<b>Varianti</b> Variants Variantes Variantes	<b>Schienali</b> Backrests Dossier Respaldos	<b>Meccanismi</b> Mechanisms Mécanismes Mecanismos	<b>Braccioli</b> Adjustable Accoudoirs Reposabrazos	<b>Colori struttura</b> Frame colours Couleurs structure Colores estructura	<b>Colori base</b> Base colours Couleurs base Colores base	<b>Rivestimenti seduta</b> Seat upholstery Revêtement de l'assise Revestimiento del asiento



# T35



**T35 è una sedia operativa elegante e moderna, adatta a offrire comfort e relax ai professionisti che trascorrono molte ore alla scrivania.**

T35 is an elegant and modern task chair, perfect for providing comfort and relaxation to professionals who spend many hours at their desks.

T35 est une chaise de travail élégante et moderne, parfaite pour offrir confort et détente aux professionnels qui passent nombreuses heures au bureau.

T35 es una silla de trabajo elegante y moderna, adecuada para ofrecer confort y relax a los profesionales que pasan muchas horas en el escritorio.

È dotata di un supporto lombare regolabile in altezza.

It features a lumbar support adjustable in height.

Le support lombaire est intégré et réglable en hauteur.

El apoyo lumbar está integrado y es ajustable en altura.



**Varianti** | Variants | Variantes | Variantes

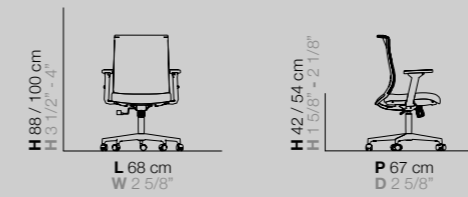

**Finiture** | Finishes | Finitions | Acabados

		<b>STD</b>			
<b>Struttura</b> Frame Structure Estructura	→			<b>Seduta</b> Seat Assise Asiento	→
<b>Base</b> Base Base Base	→			<b>Schienale</b> Backrest Dossier Respaldo	→
<b>Supporto lombare</b> Lumbar support Soutien lombaire Apoyo lumbar	→		/		

**Mix & match**

<b>Varianti</b> Variants Variantes Variantes	<b>Schienali</b> Backrests Dossier Respaldos	<b>Meccanismi</b> Mechanisms Mécanismes Mecanismos	<b>Braccioli</b> Adjustable Accoudoirs Reposabrazos	<b>Colori struttura</b> Frame colours Couleurs structure Colores estructura	<b>Colori base</b> Base colours Couleurs base Colores base	<b>Rivestimenti seduta</b> Seat upholstery Revêtement de l'assise Revestimiento del asiento

T35

T50



# T50

**T50 è una seduta che si distingue per linee arrotondate e morbide, perfetta per ambienti dal carattere dinamico ed innovativo.**

T50 is a chair distinguished by its smooth and soft lines, well suited to environments with a dynamic and innovative character.

T50 est une chaise qui se distingue par des lignes arrondies et douces, parfaite pour les environnements avec un caractère dynamique et innovant.

T50 es una silla que destaca por líneas redondeadas y suaves, perfecta para ambientes de carácter dinámico e innovador.



**La sedia presenta un supporto lombare regolabile in altezza caratterizzato da un'originale forma ovale.**

The chair features a height-adjustable lumbar support characterised by an original oval shape.

Le T50 est doté d'un support lombaire réglable en hauteur et il se caractérise par une forme ovale originale.

T50 ofrece un apoyo lumbar ajustable en altura caracterizado por una original forma oval.



**Varianti** | Variants | Variantes | Variantes

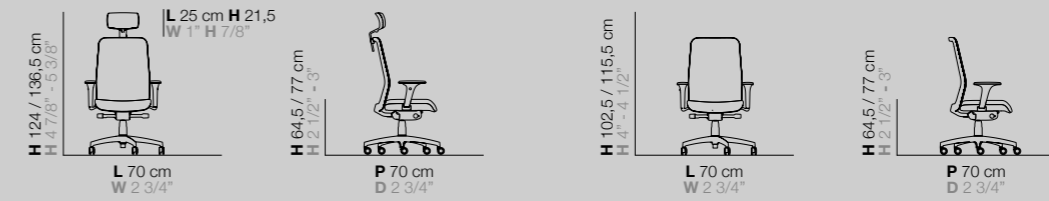

**Finiture** | Finishes | Finitions | Acabados

		<b>STD</b>			
<b>Struttura</b> Frame Structure Estructura	→			<b>Seduta</b> Seat Assise Asiento	→
<b>Base</b> Base Base Base	→			<b>Schienale</b> Backrest Dossier Respaldo	→
<b>Supporto lombare</b> Lumbar support Soutien lombaire Apoyo lumbar	→			<b>Poggiatesta</b> Headrest Appui-tête Reposacabezas	→

**Mix & match**

<b>Varianti</b> Variants Variantes Variantes	<b>Schienali</b> Backrests Dossier Respaldos	<b>Meccanismi</b> Mechanisms Mécanismes Mecanismos	<b>Braccioli</b> Adjustable Accoudoirs Reposabrazos	<b>Colori struttura</b> Frame colours Couleurs structure Colores estructura	<b>Colori base</b> Base colours Couleurs base Colores base	<b>Rivestimenti seduta</b> Seat upholstery Revêtement de l'assise Revestimiento del asiento



# T70



**T70 è una sedia full-mesh che si distingue dalle altre sedute operative per il suo design moderno e ricercato.**

T70 is a full-mesh task chair that stands out from the others for its modern and sophisticated design.

T70 est une chaise entièrement en résille qui se distingue des autres chaises opératives pour son design moderne et recherché.

T70 es una silla totalmente en malla, que destaca para su diseño moderno y sofisticado.



Lo schienale e la  
seduta sono in rete  
autoportante,  
elastica, traspirante  
e resistente.



The backrest and seat  
are in self-supporting,  
breathable and resistant  
technical mesh.

Le dossier et l'assise sont  
en résille autoportante,  
élastique, transpirante  
et résistante.

Respaldo y asiento  
son en malla autoportante,  
elástica, transpirable  
y duradera.





**Varianti** | Variants | Variantes | Variantes

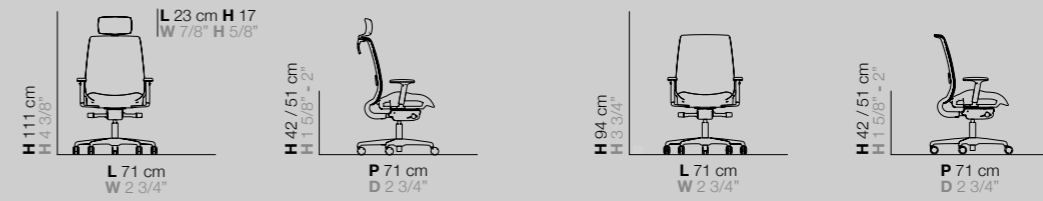

**Finiture** | Finishes | Finitions | Acabados

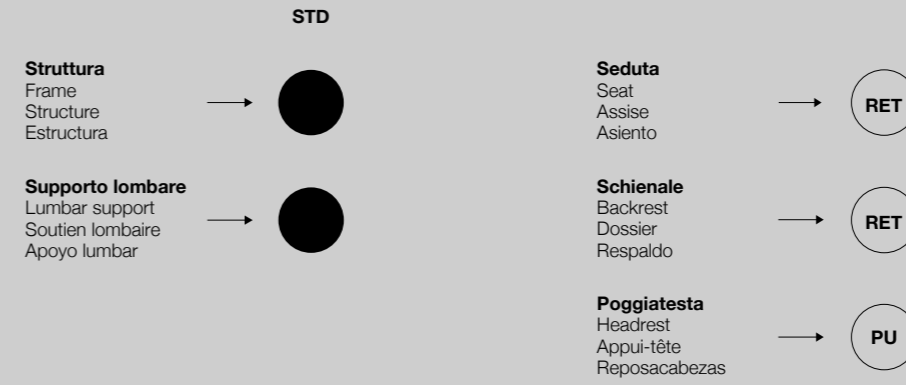

**Mix & match**



# managerial

**Le sedute “managerial” o manageriali sono una linea con una duplice importante valenza: garantire un alto livello di rappresentatività, particolarmente in contesti di incontro con persone esterne all’azienda, e assicurare il comfort per un utilizzo prolungato durante la giornata.**

**Questa linea è pensata per le figure direzionali. Le forme impiegate sono contemporanee ed ergonomiche, mettendo la funzionalità al primo posto senza rinunciare alla qualità e all’attenzione per i dettagli.**

“Managerial” chairs are a line with a dual value. They ensure a high level of representativeness (particularly for meetings with people from outside the company and, at the same time, provide comfort for extended use throughout the day.

This category of seats is intended for management profiles. The lines are comfortable and ergonomic, prioritising functionality without compromising on quality of detail.

Les “managerial” ou de gestion sont une ligne de assises avec un double valeur: garantir un haut niveau de représentativité, en particulier pour réunion avec clients, en même temps, confort pour une utilisation prolongée au cours de la journée.

Cette ligne est conçue pour figures directionnelles. Les lignes sont confortables et ergonomiques, privilégiant la fonctionnalité sans compromettre la qualité des détails.

Las sillas “managerial” o gerenciales son una línea con un doble valor importante: garantizan un alto nivel de representatividad, sobre todo en contextos de reunión con personas ajenas a la empresa, y al mismo tiempo comodidad para un uso prolongado a lo largo del día.

Esta línea está pensada para las figuras directivas. Las líneas son cómodas y ergonómicas, y dan prioridad a la funcionalidad sin renunciar a la calidad de los detalles.

34  
M10

42  
M30

48  
M50

# M10



**M10 è una sedia manageriale dai tratti leggeri ed eleganti, una perfetta fusione tra stile e comfort.**



M10 is a managerial chair with light and elegant features that perfectly combines style and comfort.

M10 est une chaise manageriale avec traits légers et élégants, une parfaite fusion de style et de confort.

M10 es una silla gerencial con características ligeras y elegantes, una fusión perfecta de estilo y comodidad.

Nel sinuoso schienale,  
in rete o rivestito in  
tessuto, è integrato  
un ergonomico  
supporto lombare  
regolabile in altezza.



The sinuous backrest is  
available in mesh or fabric  
and features an ergonomic,  
height-adjustable  
lumbar support.



Le sinueux dossier en  
résille ou en tissu est  
équipé d'un support  
lombaire ergonomique  
réglable en hauteur.

En el sinuoso respaldo,  
en malla o tapizado,  
se incorpora un apoyo  
lumbar ergonómico,  
ajustable en altura.





**Varianti** | Variants | Variantes | Variantes

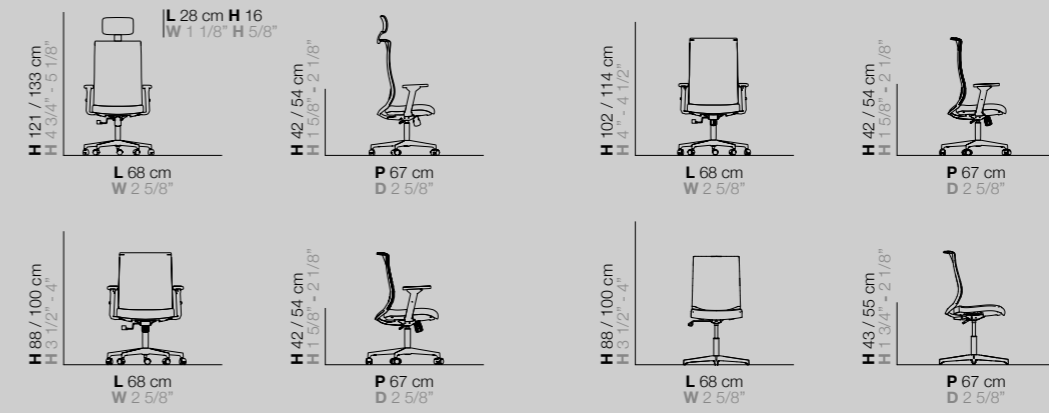

# M10

**Finiture** | Finishes | Finitions | Acabados

	STD	STD			
<b>Struttura</b> Frame Structure Estructura	→ ●	/	●	<b>Seduta</b> Seat Assise Asiento	→ ○ TES
<b>Base</b> Base Base Base	→ ●	●	●	<b>Schienale</b> Backrest Dossier Respaldo	→ ○ RET ○ TES
<b>Supporto lombare</b> Lumbar support Soutien lombaire Apoyo lumbar	→ ●	/	/	<b>Poggiatesta</b> Headrest Appui-tête Reposacabezas	→ ○ TES

**Mix & match**

○ 4	○ 2	○ 4	○ 2	○ 2	○ 3	○ 97
<b>Varianti</b> Variants Variantes Variantes	<b>Schienali</b> Backrests Dossier Respaldos	<b>Meccanismi</b> Mechanisms Mécanismes Mecanismos	<b>Braccioli</b> Adjustable Accoudoirs Reposabrazos	<b>Colori struttura</b> Frame colours Couleurs structure Colores estructura	<b>Colori base</b> Base colours Couleurs base Colores base	<b>Rivestimenti seduta</b> Seat upholstery Revêtement de l'assise Revestimiento del asiento

# M30



**M30 è un'elegante sedia manageriale caratterizzata da forme ergonomiche e morbide, perfetta per un utilizzo prolungato.**

M30 is an elegant executive chair with soft, ergonomic lines, perfect for prolonged use.

M30 est une chaise managériale élégante caractérisée par des formes ergonomiques et douces, parfaite pour une utilisation prolongée.

M30 es una silla gerencial que destaca por sus formas ergonómicas y suaves, idónea para su utilizzo prolongado.



**Il comodo schienale  
in PU schiumato è  
regolabile in altezza  
e può essere  
rivestito in tessuto,  
pelle o similpelle.**

M30



The comfortable PU foam backrest is height-adjustable and can be upholstered in fabric, leather or faux leather.

Le dossier confortable en mousse PU, est réglable en hauteur et il peut être revêtu en tissu, cuir ou faux-cuir.

El cómodo respaldo en espuma de PU es regulable en altura y puede tapizarse en tela, cuero o eco-piel.







**Varianti** | Variants | Variantes | Variantes

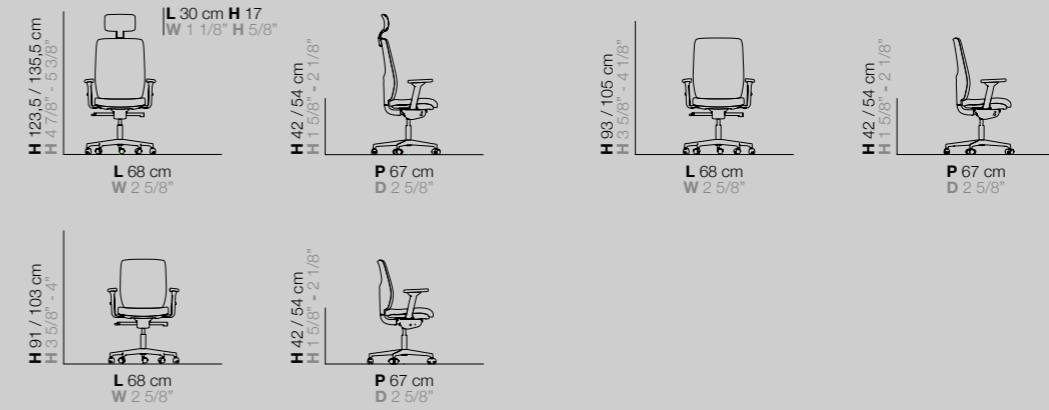

M30

**Finiture** | Finishes | Finitions | Acabados

	STD	STD			
<b>Struttura</b> Frame Structure Estructura	→	/		<b>Seduta</b> Seat Assise Asiento	→
<b>Base</b> Base Base Base	→			<b>Schienale</b> Backrest Dossier Respaldo	→
				<b>Poggiatesta</b> Headrest Appui-tête Reposacabezas	→

**Mix & match**

<b>Varianti</b> Variants Variantes Variantes	<b>Schienali</b> Backrests Dossier Respaldos	<b>Meccanismi</b> Mechanisms Mécanismes Mecanismos	<b>Braccioli</b> Adjustable Accoudoirs Reposabrazos	<b>Colori struttura</b> Frame colours Couleurs structure Colores estructura	<b>Colori base</b> Base colours Couleurs base Colores base	<b>Rivestimenti seduta</b> Seat upholstery Revêtement de l'assise Revestimiento del asiento

# M50



**M50 è una sedia manageriale dal carattere deciso e dalle linee autorevoli, perfetta per ambienti eleganti e sofisticati.**

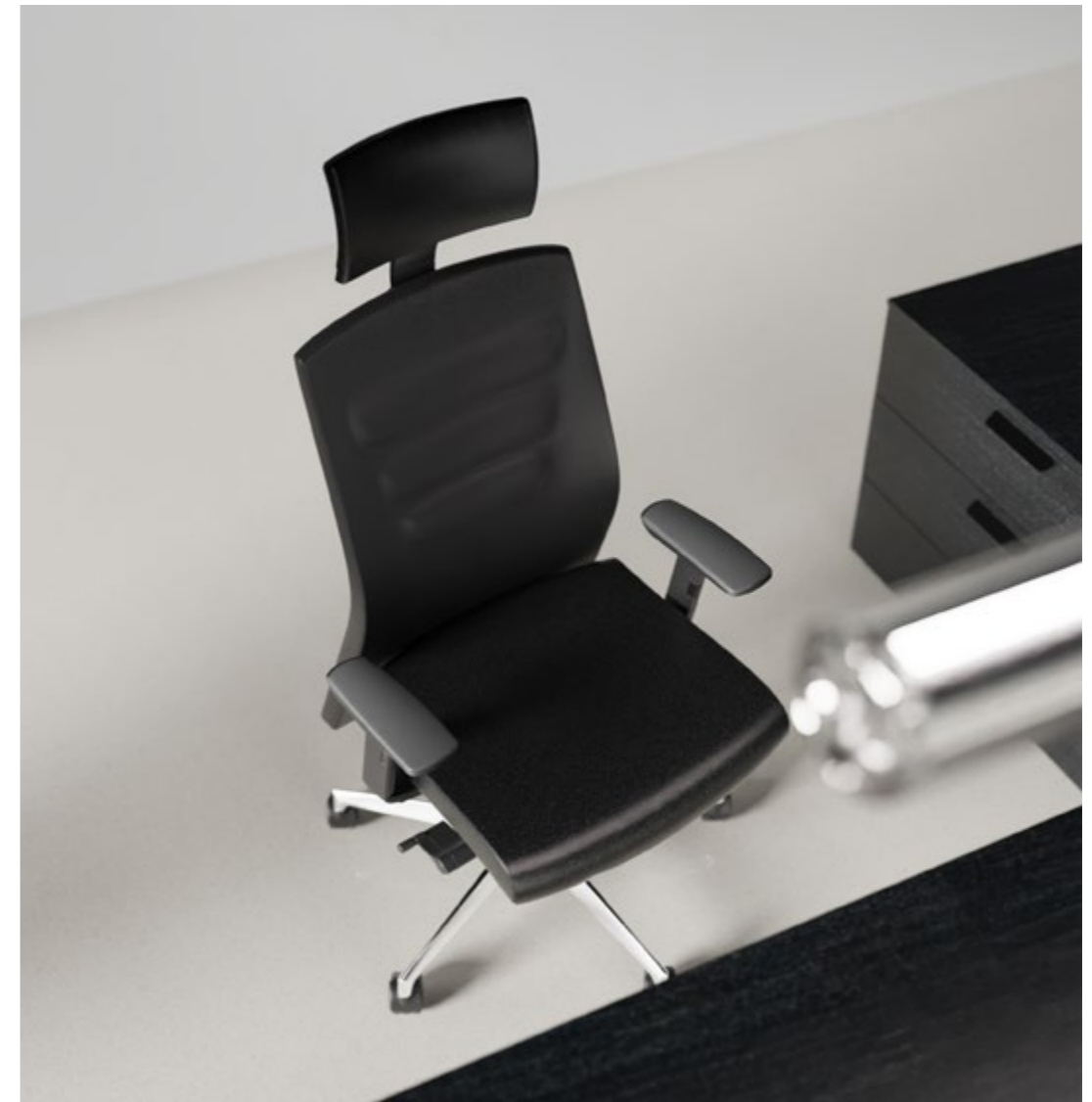

M50 is a managerial chair with a strong character and authoritative lines, perfect for elegant and sophisticated environments.

M50 est une chaise mangériale avec un caractère décidé et des lignes d'autorité, parfaite pour les environnements élégants et sophistiqués.

M50 es una silla gerencial con carácter fuerte y líneas decididas, ideal para ambientes elegantes y sofisticados.



**Le linee raffinate e i  
dettagli tecnici  
rendono la poltrona  
ergonomica, comoda  
e dallo stile ricercato.**



Its refined lines and  
technical details make it an  
ergonomic, comfortable,  
and sophisticated armchair.

Les lignes raffinées et les  
détails techniques rendent  
cette chaise ergonomique,  
confortable et avec une  
style recherché.

Las líneas refinadas y  
los detalles técnicos, la  
convierten en un sillón  
ergonómico, cómodo y con  
un estilo sofisticado.





**Varianti** | Variants | Variantes | Variantes

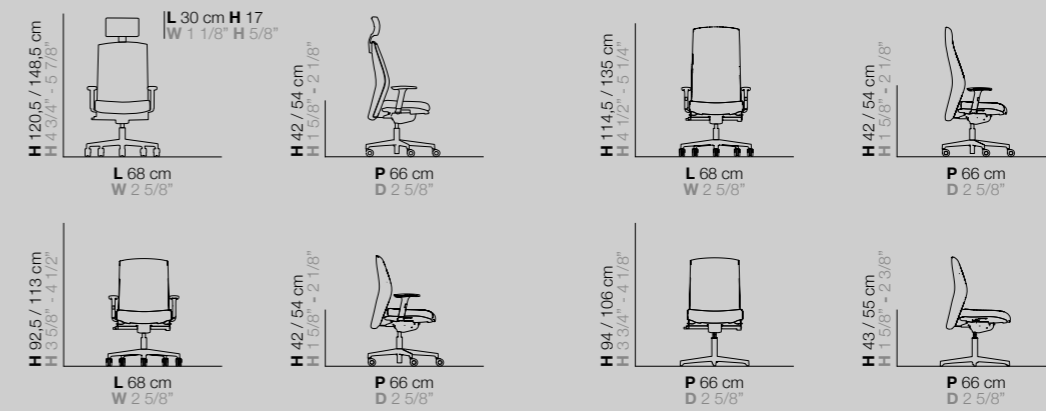

# M50

**Finiture** | Finishes | Finitions | Acabados

	<b>STD</b>	<b>STD</b>		
<b>Struttura</b> Frame Structure Estructura	→ ●	/	<b>Seduta</b> Seat Assise Asiento	→ ○ <b>TES</b> ○ <b>PEL</b>
<b>Base</b> Base Base Base	→ ●	○	<b>Schienale</b> Backrest Dossier Respaldo	→ ○ <b>TES</b> ○ <b>PEL</b>
			<b>Poggiatesta</b> Headrest Appui-tête Reposacabezas	→ ○ <b>TES</b> ○ <b>PEL</b>

**Mix & match**

4	2	3	3	1	2	106
<b>Varianti</b> Variants Variantes Variantes	<b>Schienali</b> Backrests Dossier Respaldos	<b>Meccanismi</b> Mechanisms Mécanismes Mecanismos	<b>Braccioli</b> Adjustable Accoudoirs Reposabrazos	<b>Colori struttura</b> Frame colours Couleurs structure Colores estructura	<b>Colori base</b> Base colours Couleurs base Colores base	<b>Rivestimenti seduta</b> Seat upholstery Revêtement de l'assise Revestimiento del asiento

# executive

**Le sedute “executive” o direzionali esprimono in modo chiaro e immediato lo stile rappresentativo e unico di un’azienda e del suo management.**

**Attraverso un’attenta ricerca progettuale, la qualità dei materiali utilizzati (es. pelle ed simil-pelle) e la cura di ogni minimo dettaglio, coniugano prestigio e autorevolezza, design ed efficienza, funzionalità ed ergonomia.**

“Executive” chairs clearly and immediately express the representative and unique style of a company and its management.

Thanks to careful design research, quality of the materials used (e.g. leather and faux leather) and attention to even the smallest detail, they combine prestige and authority, design and efficiency, functionality and ergonomics.

Les chaises “executive” ou de direction expriment avec instantanéité et clarté la représentativité et un style distinctif d’une entreprise et ses dirigeants.

Grâce à une recherche attentive relative aux projets, la qualité des matériaux utilisés (par ex. cuir et faux-cuir) et le soin de chaque détail, allient prestige et autorité, design et efficacité, fonctionnalité et ergonomie.

Los asientos “executive” o ejecutivos expresan con inmediatez y claridad la representatividad y el estilo distintivo de una empresa y, en particular, de sus dirigentes.

La cuidadosa investigación de diseño, la calidad de los materiales utilizados, como cuero y ecopiel, y la atención a cada detalle combinan prestigio y autoridad, estética y eficiencia, funcionalidad y ergonomía.

58  
E10

66  
E30

74  
E50

# E10



**E10 è una collezione di poltrone direzionali caratterizzate da linee pulite e sofisticate, perfette per uffici moderni e classici.**

E10 is a collection of executive chairs characterised by clean and sophisticated lines, perfect for both modern and classic offices.

E10 est une collection de chaises qui est caractérisée par des lignes claires et sophistiquées, qui la rend polyvalente pour bureaux modernes que classiques.

E10 es una colección de asientos que se caracteriza por líneas limpias y sofisticadas, que la hacen versátil tanto para oficinas modernas como clásicas.



# E10

**Lo schienale può essere in rete autoportante, tessuto o in pelle. La struttura può essere cromata o verniciata su richiesta.**

The backrest is available in mesh or upholstered fabric, leather or faux leather. The frame can be chrome-plated or powder-coated in a matching colour.

Le dossier est disponible en résille autoportante, ou en tissu ou en cuir. La structure peut être chromée ou vernie sur demande.

El respaldo está fabricado en malla autoportante, tela o cuero. La estructura puede cromarse o pintarse bajo pedido.







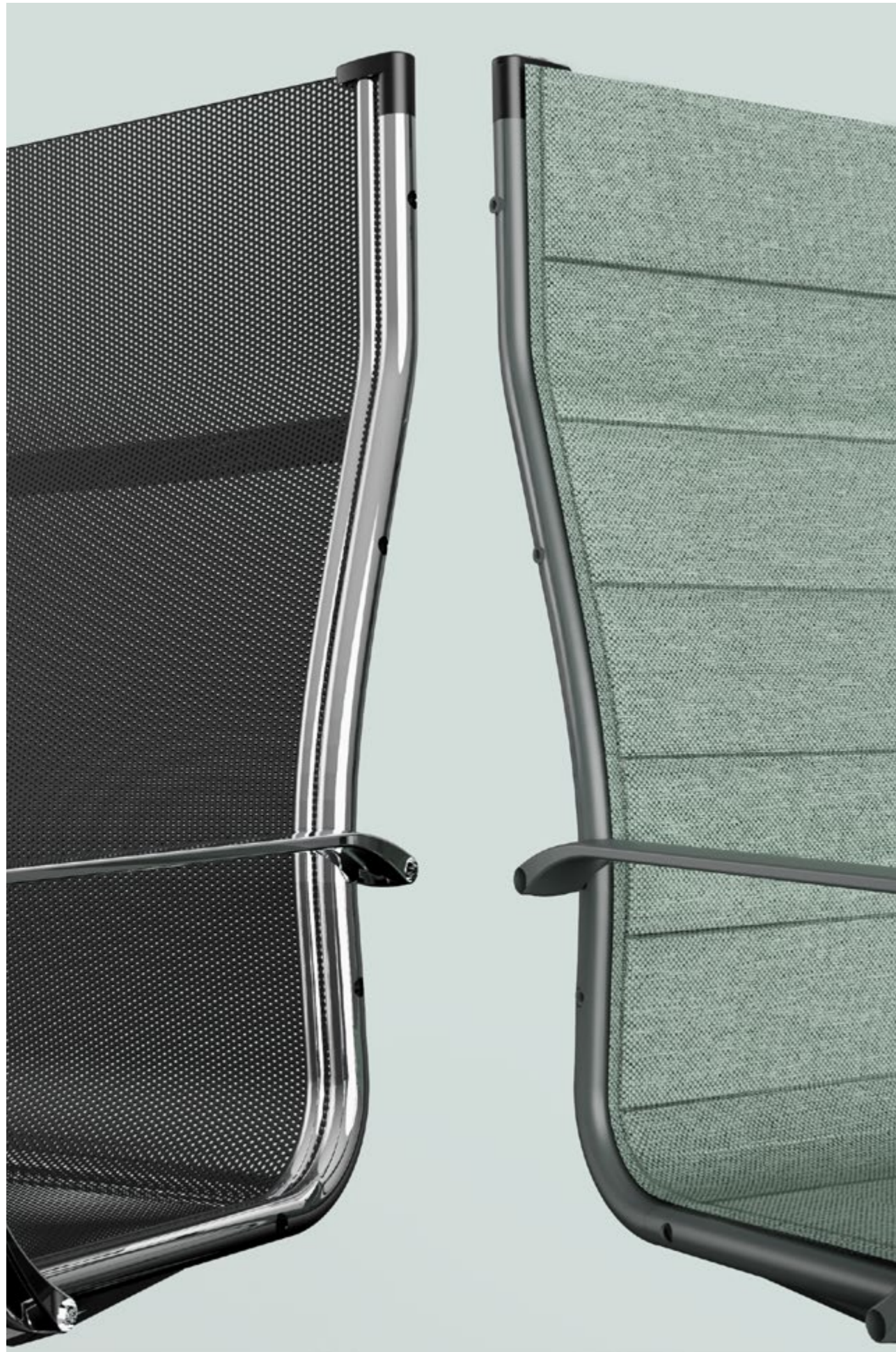

**Varianti** | Variants | Variantes | Variantes

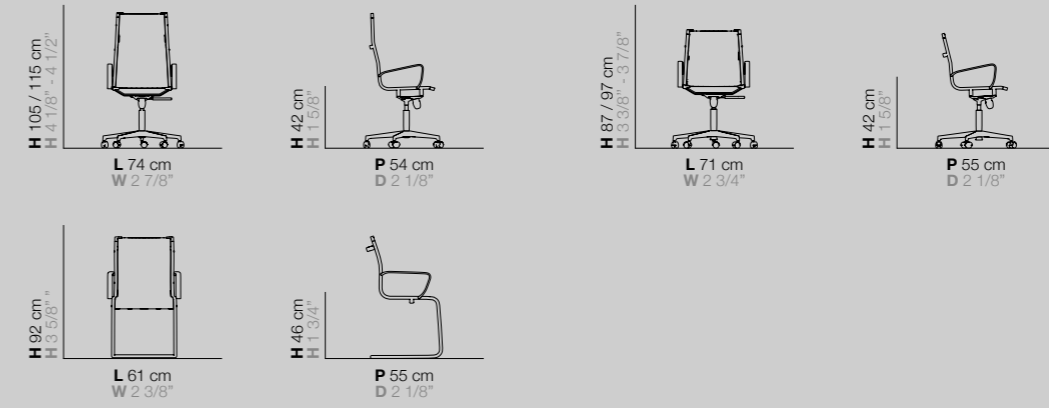

E10

**Finiture** | Finishes | Finitions | Acabados

	STD	STD			
<b>Struttura</b> Frame Structure Estructura	→	→	→	<b>Seduta</b> Seat Assise Asiento	→
<b>Base</b> Base Base Base	→	→	→	<b>Schienale</b> Backrest Dossier Respaldo	→

**Mix & match**

<b>Varianti</b> Variants Variantes Variantes	<b>Schienali</b> Backrests Dossier Respaldos	<b>Meccanismi</b> Mechanisms Mécanismes Mecanismos	<b>Braccioli</b> Adjustable Accoudoirs Reposabrazos	<b>Colori struttura</b> Frame colours Couleurs structure Colores estructura	<b>Colori base</b> Base colours Couleurs base Colores base	<b>Rivestimenti seduta</b> Seat upholstery Revêtement de l'assise Revestimiento del asiento

# E30

**E30 si caratterizza per le linee morbide ed avvolgenti, per un design classico che dona importanza all'ambiente ufficio.**



E30 is characterised by soft, enveloping lines and a classic design that enhances the office environment.

E30 se caractérise par des lignes douces et enveloppantes, pour un design classique qui donne importance à l'environnement du bureau.

E30 se caracteriza por sus líneas suaves y envolventes, para un diseño clásico que confiere importancia al entorno de oficina.

Può essere rivestita  
sia in tessuto che  
in pelle in base alle  
esigenze del cliente.



Depending on the  
customer's requirements,  
it can be upholstered  
in fabric, leather  
or faux leather.

Elle peut être revêtue en  
tissu mais aussi en  
cuir selon les  
exigences du client.

Puede tapizarse en  
tela o cuero, según  
las necesidades del cliente.





**Varianti** | Variants | Variantes | Variantes

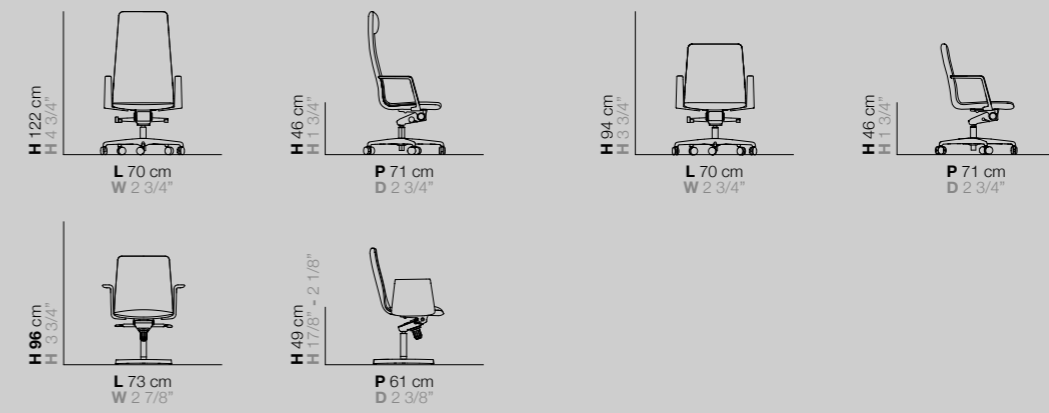

E30

**Finiture** | Finishes | Finitions | Acabados

**STD**

<b>Struttura</b> Frame Structure Estructura	→		<b>Seduta</b> Seat Assise Asiento	→	
<b>Base</b> Base Base Base	→		<b>Schienale</b> Backrest Dossier Respaldo	→	

**Mix & match**

<b>Varianti</b> Variants Variantes Variantes	<b>Schienali</b> Backrests Dossier Respaldos	<b>Meccanismi</b> Mechanisms Mécanismes Mecanismos	<b>Braccioli</b> Adjustable Accoudoirs Reposabrazos	<b>Colori struttura</b> Frame colours Couleurs structure Colores estructura	<b>Colori base</b> Base colours Couleurs base Colores base	<b>Rivestimenti seduta</b> Seat upholstery Revêtement de l'assise Revestimiento del asiento

E50



# E50

**E50 è una seduta dal carattere deciso e importante. Un design forte che connota l'ambiente di lavoro.**



E50 is a chair with a strong character and a distinctive design, which plays a leading role in the environment in which it is placed.

E50 est une chaise avec un caractère décisif et important. Un design fort qui donne une importance à l'environnement de travail.

E50 es un asiento con un carácter decidido e importante. Se presenta con un diseño fuerte, que caracteriza el entorno de trabajo.

**La forma particolare della seduta rende questa poltrona direzionale un must di accoglienza.**

The unusual shape of the seat makes this executive chair an inviting must-have.

La forme particulière de la chaise rend ce fauteuil de direction un must de l'accueil.

La forma particular del asiento hace que este sillón gerencial sea imprescindible en cada recepción.









**Varianti** | Variants | Variantes | Variantes

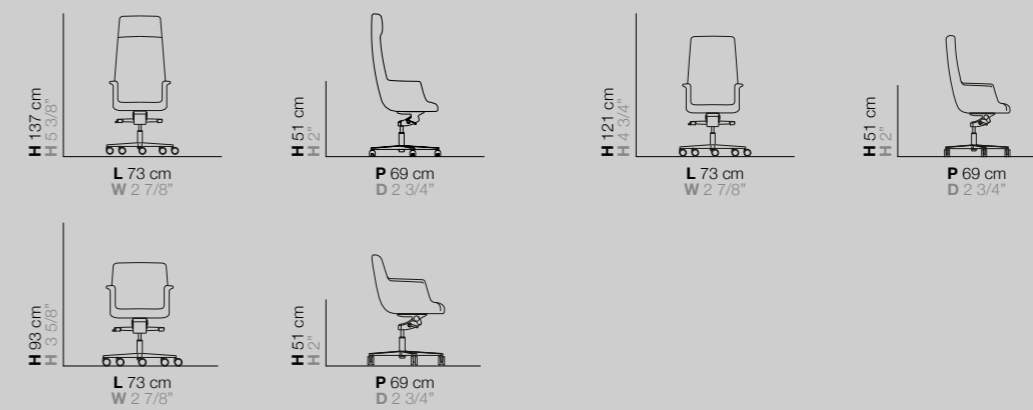

E50

**Finiture** | Finishes | Finitions | Acabados

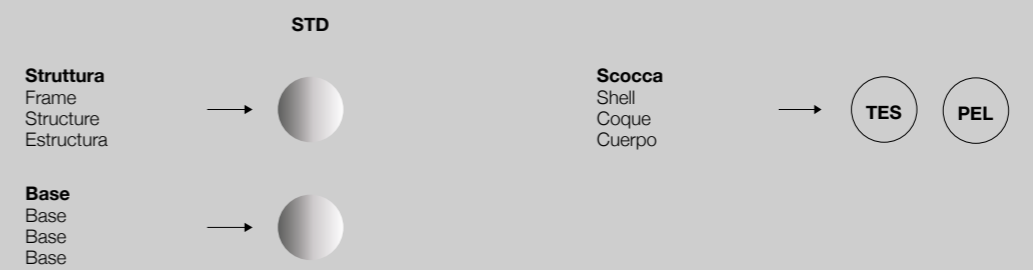

**Mix & match**



# visitor

**Le sedute “visitor” o visitatore sono ideali per un utilizzo non prolungato, progetti contract, allestimento di sale d’attesa di studi professionali oppure per sale riunioni, conferenze aziendali o d’ufficio, oltre che per funzioni di servizio in ambiti domestici.**

**Si tratta di sedie che si caratterizzano per la massima versatilità, pensate per garantire il miglior equilibrio possibile fra necessità di comfort, praticità e distintiva eleganza.**

“Visitor” chairs are designed for short-term use, ideal for contract projects, for furnishing waiting rooms in professional and medical environments, for business or office meetings and conferences, and for service functions in domestic environments.

These chairs are characterised by maximum versatility in order to guarantee the best possible balance between the need for comfort and prestige. They are of remarkable practicality and at the same time of unmistakable elegance.

Les assises “visitor” ou visiteurs sont parfaites pour une utilisation pas prolongée, idéales pour projets contract, la mise en place pour les salles d’attente de bureaux professionnels, réunions, conférences, ainsi que pour fonctions de service domestique.

Il s’agit de chaises très polyvalentes, pensées pour assurer le meilleur équilibre entre nécessité de confort, grande praticité et d’une élégance distinctive.

Las sillas “visitor” o de visita son adecuadas para un uso no prolongado, ideales para proyectos contract, la decoración de salas de espera en despachos profesionales y médicos, reuniones y conferencias en empresas u oficinas, así como para funciones de servicio en entornos domésticos.

Estas sillas se caracterizan por su máxima versatilidad, diseñadas para garantizar el mejor equilibrio posible entre comodidad, practicidad y una elegancia distintiva.

84  
V20

# V20



**V20 è una seduta versatile, che si adatta a diverse tipologie di ambiente. Presenta linee eleganti e semplici che le danno un tocco moderno.**

V20 is a versatile chair that adapts to different types of environments. It has elegant and simple lines that give it a modern touch.

V20 est une chaise polyvalente, qui s'adapte aux différents types d'environnement. Elle est équipée de lignes élégantes et simples que lui donnent une touche moderne.

V20 es un asiento inteligente, que se adapta a diferentes tipos de entorno. Presenta unas líneas elegantes y sencillas que le confieren un toque moderno.



La struttura è disponibile nelle varianti bianco e nero e la seduta può essere rivestita con la vasta gamma di tessuti disponibili.



The frame is available in white or black and the seat can be upholstered in a wide range of fabrics.

La structure est disponible en blanc et en noir et l'assise peut être revêtue en toutes finitions disponibles.

La estructura está disponible en blanco y negro, colores acompañados por una amplia gama de tejidos ecosostenibles.





Varianti | Variants | Variantes | Variantes

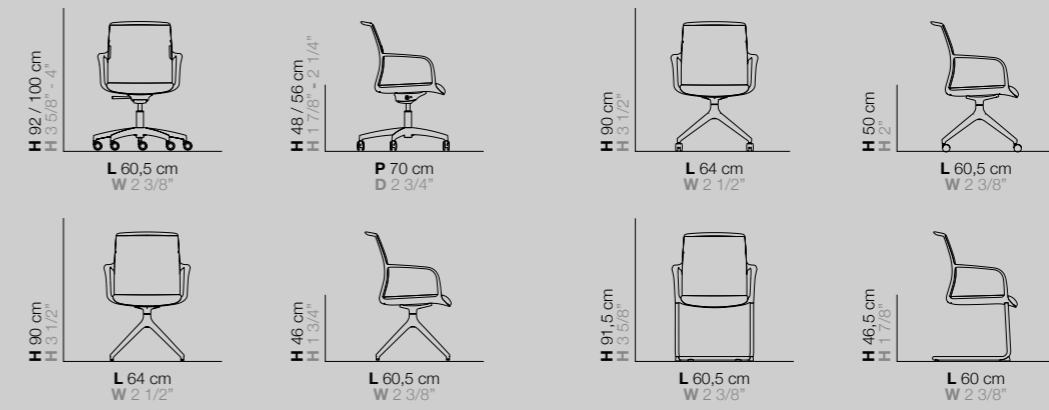

V20

Finiture | Finishes | Finitions | Acabados

	<p>STD </p>	
<p><b>Struttura</b> Frame Structure Estructura</p>	<p>→ ● ●</p>	<p><b>Seduta</b> Seat Siège Asiento</p>
<p><b>Base</b> Base Base Base</p>	<p>→ ● ●</p>	<p>→ ● ●</p> <p>TES PEL</p>
		<p><b>Schienale</b> Backrest Dossier Respaldo</p>
		<p>→ ●</p> <p>RET</p>

Mix & match

4	1	2	2	2	106
<p><b>Varianti</b> Variants Variantes Variantes</p>	<p><b>Schienali</b> Backrests Dossier Respaldos</p>	<p><b>Meccanismi</b> Mechanisms Mécanismes Mecanismos</p>	<p><b>Colori struttura</b> Frame colours Couleurs structure Colores estructura</p>	<p><b>Colori base</b> Base colours Couleurs base Colores base</p>	<p><b>Rivestimenti seduta</b> Seat upholstery Revêtement de l'assise Revestimiento del asiento</p>

# hybrid

**La categoria “hybrid” o ibrida vuole soddisfare particolari esigenze che non trovano piena risposta dalle altre linee più specifiche.**

**Le sedute sono versatili e si adattano facilmente a diverse tipologie di ambienti.**

**Sono prodotti dalle linee più semplici, che non presentano particolari rivestimenti e finiture. Conseguentemente, sono ideali ad accompagnare tavoli hot-desking o riunione.**

The ‘Hybrid’ category is designed to meet specific needs that are not fully met by other, more specific lines.

The chairs are versatile and easily adaptable to different types of environments.

These chairs have clean and essential lines and do not have special upholstery and finishes. This makes them ideal for hot-desking or meeting tables.

La catégorie “hybride” ou hybride est destinée à répondre à des besoins particuliers qui ne sont pas entièrement satisfaits par les autres lignes plus spécifiques.

Les chaises sont polyvalentes et s’adaptent facilement à différents types d’environnements.

Il s’agit de produits aux lignes plus simples, sans rembourrage ni finitions particulières. Par conséquent, elles sont idéales pour accompagner les tables de hot-desking ou de réunion.

La categoría “híbrida” o híbrida está pensada para satisfacer necesidades particulares que no quedan totalmente cubiertas por las otras líneas más específicas. Son asientos versátiles que se adaptan fácilmente a distintos tipos de entornos.

Son productos de líneas más sencillas que no presentan tapizados ni acabados especiales.

En consecuencia, son ideales para acompañar mesas de hot-desking o de reuniones.

94  
H10



# H10



**H10 è una collezione di sedute ibride dal design tecnico ed essenziale. La sua versatilità la rende perfettamente collocabile in diversi ambiti e contesti.**

H10 is a collection of hybrid chairs with an essential and technical design. Its versatility makes it perfectly adaptable to different spaces and contexts.

H10 est une collection de chaises hybrides avec un design technique et essentiel. Elle trouve une parfaite collocation dans nombreux domaines et espaces.

H10 es una colección de asientos híbridos con un diseño técnico y esencial. Su versatilidad la hace perfectamente ubicable en múltiples ámbitos y espacios.





La seduta è interamente in rete e nel basamento dello sgabello è presente un poggiapiedi ad anello in acciaio.



The seat is made entirely of mesh and the stool base is fitted with an aluminium ring footrest.

La chaise est entièrement en résille et la structure du tabouret est équipée d'un repose-pieds en anneau d'acier.

El asiento es totalmente de malla y en la base del taburete hay un reposapiés de aro de acero.



**Varianti** | Variants | Variantes | Variantes

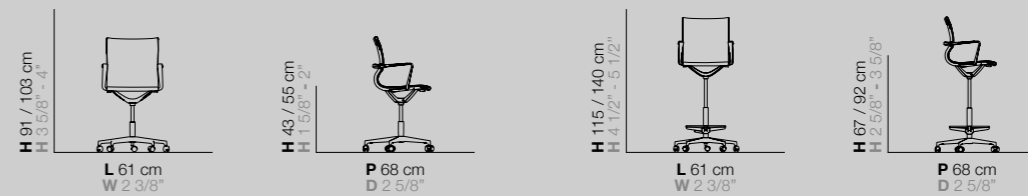

H10

**Finiture** | Finishes | Finitions | Acabados

	STD	STD		
<b>Struttura</b> Frame Structure Estructura	→ ●	/	<b>Seduta</b> Seat Assise Asiento	→ ○ RET
<b>Base</b> Base Base Base	→ ●	○	<b>Schienale</b> Backrest Dossier Respaldo	→ ○ RET

**Mix & match**

○ 2	○ 1	○ 2	○ 1	○ 2
<b>Varianti</b> Variants Variantes Variantes	<b>Schienali</b> Backrests Dossier Respaldos	<b>Meccanismi</b> Mechanisms Mécanismes Mecanismos	<b>Colori struttura</b> Frame colours Couleurs structure Colores estructura	<b>Colori base</b> Base colours Couleurs base Colores base

# community

**Le sedute “community” o per la collettività soddisfano le esigenze di platee numerose o luoghi con cambio frequente di fruitori (locali pubblici, sia al chiuso che all’aperto).**

**Sono estremamente leggere e maneggevoli, per favorirne gli spostamenti durante gli allestimenti. La loro impilabilità conferisce un valore aggiunto, che ne facilita lo stoccaggio.**

“Community” chairs are great for accommodating large groups of people and for places with a high turnover rate. They can be found indoors and outdoors and are ideal for public spaces.

They are incredibly lightweight and manoeuvrable, making them easy to move around when setting up. Their stackability adds value by making them easier to store.

Les assises “Community” ou pour la communauté sont idéales pour accueillir de grands groupes de personnes ou pour les lieux où le taux de rotation est élevé. On les trouve à l’intérieur et à l’extérieur et elles sont idéales pour les espaces publics.

Elles sont incroyablement légères et maniables, ce qui permet de les déplacer facilement lors de l’installation. Leur empilabilité confère une valeur ajoutée en facilitant leur stockage.

Las sillas “Community” o para colectividades son ideales para acomodar a grandes grupos de personas y para lugares con un alto índice de rotación. Se pueden encontrar en interiores y exteriores y son ideales para espacios públicos.

Son increíblemente ligeras y maniobrables, lo que facilita su desplazamiento durante el montaje. Además, son apilables, lo que facilita su almacenamiento.

**102**  
**C10**

**108**  
**C20**

# C10



**C10 è una sedia dalle linee minimal ed essenziali, perfetta per gli ambienti outdoor.**

C10 is a community chair with minimal and essential lines, perfect for outdoor environments.

C10 est une chaise communautaire aux lignes minimales et essentielles, parfaite pour les environnements extérieurs.

C10 es una silla comunitaria de líneas minimalistas y esenciales, perfecta para entornos exteriores.

La sua struttura a monoblocco in polipropilene garantisce notevole durabilità nel tempo e resistenza agli agenti atmosferici.

# C10



Its one-piece polypropylene frame guarantees remarkable durability and weather resistance.

Sa structure en monobloc de polypropylène garantit une considérable durabilité dans le temps et résistance aux agents atmosphériques.

Su estructura en monobloque de polipropileno garantiza una notable durabilidad en el tiempo y resistencia a los agentes atmosféricos.



**Tra le declinazioni possibili per C10 troviamo @Rinasco, la versione totalmente riciclata.**

Possible declinations for C10 include @Rinasco, the fully recycled version.

Parmi les déclinaisons possibles pour C10 on trouve @Rinasco, la version totalement recyclée.

Entre las posibles declinaciones para C10 encontramos @Rinasco, la versión totalmente reciclada.



**Impilabilità**  
Stackability  
Empilabilité  
Apilabilidad

**POL**  
**MAX 5 PZ**  
PCS PCS PIEZAS



**Impilabilità**  
Stackability  
Empilabilité  
Apilabilidad

**POL**  
**MAX 5 PZ**  
PCS PCS PIEZAS



2024  
COMING  
SOON

2024  
COMING  
SOON

**Varianti** | Variants | Variantes | Variantes

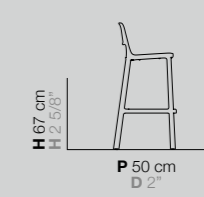
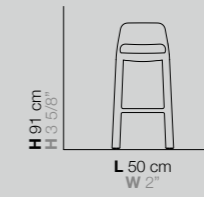
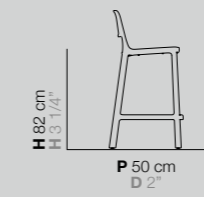
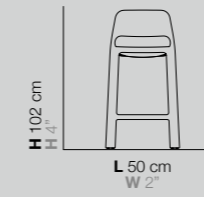
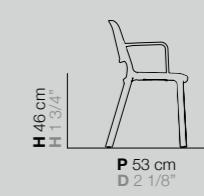
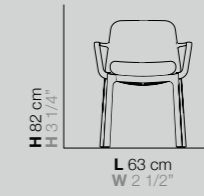
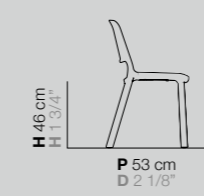
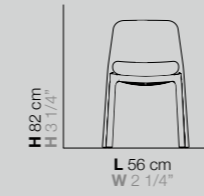

**Finiture** | Finishes | Finitions | Acabados

**STD**

**Struttura polipropilene**  
Polypropylene structure  
Structure en polypropylène  
Estructura de polipropileno

**100% riciclato - Rinasco®**  
100% recycled - Rinasco®  
100% recyclé - Rinasco®  
100% reciclado - Rinasco®

**Mix & match**



**Varianti**  
Variants  
Variantes  
Variantes



**Colori struttura**  
Frame colours  
Couleurs structure  
Colores estructura

**C10**

# C20

**C20 è la soluzione perfetta per ogni tipo di platea. La collezione si declina in otto differenti tipologie di sedute per rispondere a tutte le esigenze del cliente.**



C20 is the perfect solution for every type of audience. The collection is available in eight different types of seating to meet all customer requirements.

C20 est une solution parfaite pour tout type de public. La collection se décline en huit différents types de chaises pour répondre à tous besoins des clients.

C20 es la solución perfecta para todo tipo de público. La colección está disponible en ocho tipos de asientos para satisfacer todas las necesidades de los clientes.



La scocca è  
disponibile anche  
nella versione  
con rivestimento  
anteriore, che ne  
esalta la versatilità di  
utilizzo ed il comfort.



The chair is also available  
with front upholstery  
for added versatility  
and comfort.

La coque est également  
disponible dans une version  
recouverte sur le devant, ce  
qui améliore sa polyvalence  
d'utilisation et son confort.

La carcasa también está  
disponible en una versión  
cubierta por delante, lo que  
aumenta su versatilidad de  
uso y comodidad.





**Impilabilità**  
Stackability  
Empilabilité  
Apilabilidad

POL  
**MAX 15 PZ**  
PCS PCS PIEZAS



**Impilabilità**  
Stackability  
Empilabilité  
Apilabilidad

POL  
**MAX 20 PZ**  
PCS PCS PIEZAS

TES  
**MAX 15 PZ**  
PCS PCS PIEZAS



**Impilabilità**  
Stackability  
Empilabilité  
Apilabilidad

TES  
**MAX 10 PZ**  
PCS PCS PIEZAS



**Impilabilità**  
Stackability  
Empilabilité  
Apilabilidad

POL  
**MAX 15 PZ**  
PCS PCS PIEZAS

TES  
**MAX 10 PZ**  
PCS PCS PIEZAS



**Impilabilità**  
Stackability  
Empilabilité  
Apilabilidad

POL  
**MAX 20 PZ**  
PCS PCS PIEZAS

TES  
**MAX 15 PZ**  
PCS PCS PIEZAS



**Impilabilità**  
Stackability  
Empilabilité  
Apilabilidad

POL  
**MAX 15 PZ**  
PCS PCS PIEZAS

TES  
**MAX 10 PZ**  
PCS PCS PIEZAS





# C20

## Varianti | Variants | Variantes | Variantes

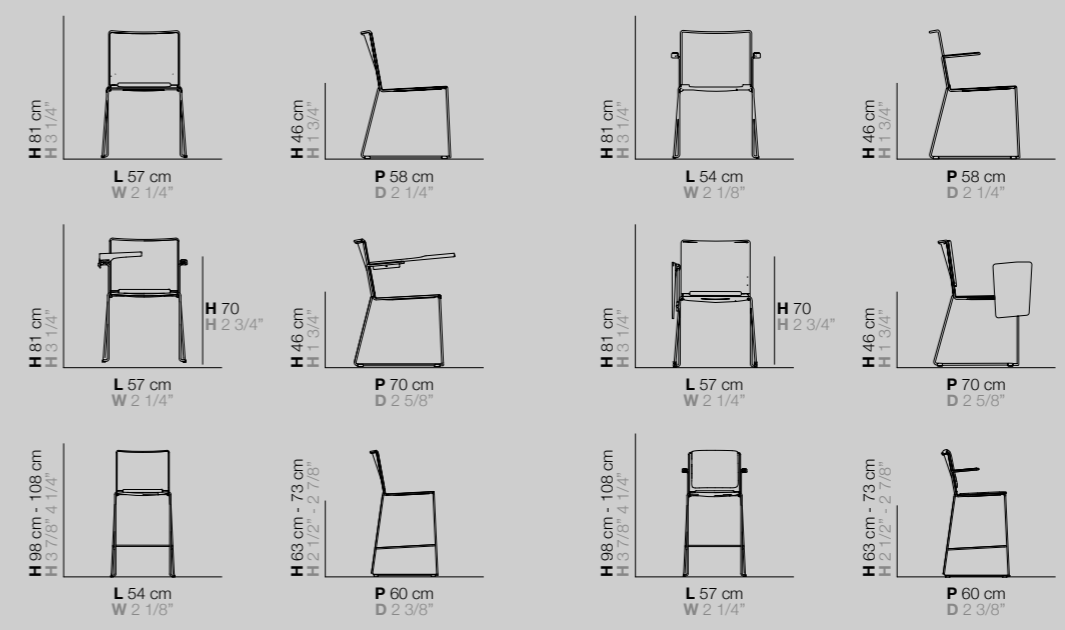



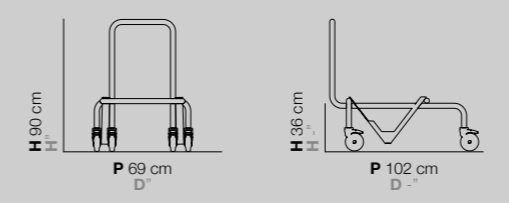



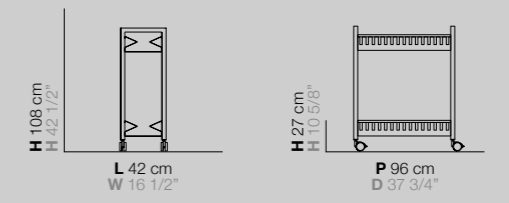



## Carrello | Trolley | Chariot | Carrito







## Carrello | Trolley | Chariot | Carrito



## Finiture | Finishes | Finitions | Acabados

	STD	STD	STD			
<b>Scocca</b> Shell Coque Concha			/			<b>Seduta</b> Seat Assise Asiento → <b>TES</b>
<b>Struttura senza scrittoio</b> Frame without writing table Structure sans tablette écrioire Estructura sin escritorio						<b>Schienale</b> Backrest Dossier Respaldo → <b>TES</b>
<b>Struttura con scrittoio</b> Frame with writing table Structure avec tablette écrioire Estructura con escritorio	/	/				

## Mix & match

				
<b>Varianti</b> Variants Variantes	<b>Scocca</b> Shell Coque Concha	<b>Struttura senza tavoletta</b> Frame without writing table Structure sans tablette écrioire Estructura sin escritorio	<b>Struttura con tavoletta</b> Frame with writing table Structure avec tablette écrioire Estructura con escritorio	<b>Tessuti</b> Fabrics Tissus Tejidos

# materials and finishes

## **POL** **POLIPROPILENE**

Polypropylene | Polypropylène | Polipropileno

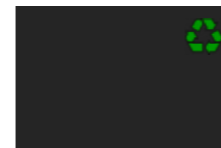

**Carbone - Mod. C10**  
Charcoal  
Charbon  
Carbón



**Roccia - Mod. C10**  
Rock  
Roche  
Roca



**Neve - Mod. C10**  
Snow  
Neige  
Nieve



**Cielo - Mod. C10**  
Sky  
Ciel  
Cielo



**Tè verde - Mod. C10**  
Green tea  
Thé vert  
Té verde

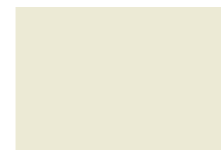

**Crema - Mod. C10**  
Cream  
Crème  
Crema



**Zucca - Mod. C10**  
Pumpkin  
Citrouille  
Calabaza

## **POL** **POLIPROPILENE**

Polypropylene | Polypropylène | Polipropileno

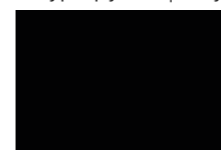

**Grafite - Mod. C20**  
Graphite  
Graphite  
Grafito



**Cenere - Mod. C20**  
Ash  
Cendre  
Ceniza



**Ghiaccio - Mod. C20**  
Ice white  
Glace  
Hielo



**Nocciola - Mod. C20**  
Hazelnut  
Noisette  
Avellana

## RET

### RETE MEGA

Mega mesh | Résille Mega | Malla Mega



001 -  
Mod. T10, T30, T50, M10

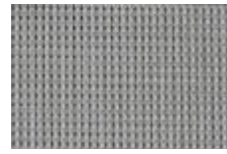

003 -  
Mod. T10, T30, T50, M10

### RETE PORTANTE

Supporting mesh | Résille de soutien | Malla reforzada

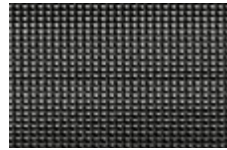

N00 - Mod. E10



N09 - Mod. E10



BL - Mod. T70, V20

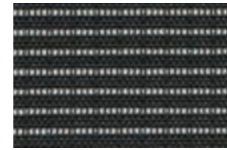

NK00 - Mod. H10



NK09 - Mod. H10

## TES

### BRAVO - Fidivi (CAT. S)

Tessuto | Fabric | Tissu | Tejido



8033



8009

## SECRET - Flukso (CAT. A)

Similpelle | Faux leather | Faux-cuir | Semipiel

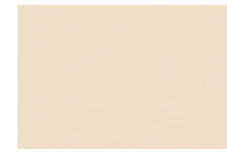

1003



1024



1006



1026



1019



1033



1012



1014



1017

## ONE - Fidivi (CAT. A)

Tessuto | Fabric | Tissu | Tejido



8504



1506



4037



4503



3530



7521



7526



6555

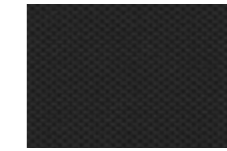

8033

**CURA - Gabriel (CAT. A)**

Tessuto | Fabric | Tissu | Tejido

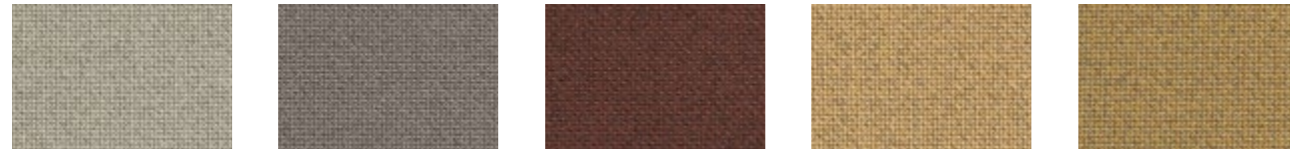

61168 60110 61258 61233 62083

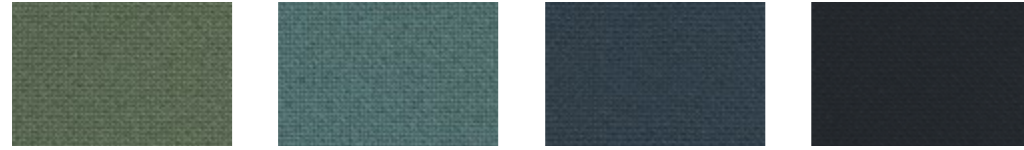

68182 66167 66170 60111

**JET - Fidivi (CAT. A)**

Tessuto | Fabric | Tissu | Tejido



9110 9804 9108 9402 9301



9305 9703 9702 7014 9608

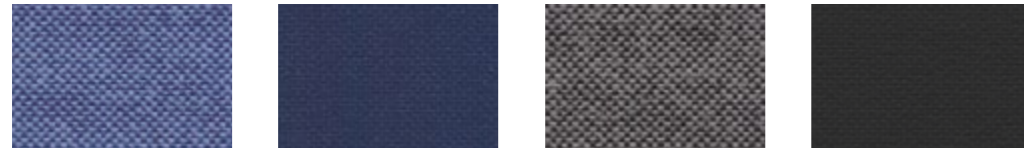

9601 6098 9294 8033

**GO UNI - Gabriel (CAT. B)**

Tessuto | Fabric | Tissu | Tejido



66138 60093 60083 66139 61145



61144 67071 68149 60999

**GO CHECK - Gabriel (CAT. B)**

Tessuto | Fabric | Tissu | Tejido



60093 60083 60084 61145 61141



61139 68149 66139 66138

**ACTON - Vescom (CAT. C)**

Tessuto | Fabric | Tissu | Tejido



7062.20 7062.06 7062.05 7062.11 7062.29



7062.31 7062.32 7062.19 7062.18

**PASSION - Gabriel (CAT. D)**

Tessuto | Fabric | Tissu | Tejido



13101 1101 4101 16101 2101

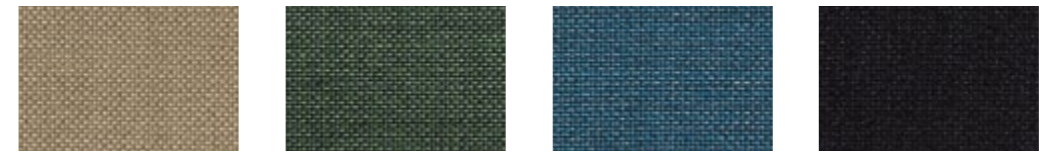

8101 24101 20101 12101

**WOLIN - Vescom (CAT. D)**

Tessuto | Fabric | Tissu | Tejido



7050.17



7050.03



7050.26



7050.47

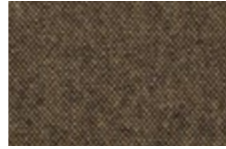

7050.19



7050.37



7050.42



7050.09



7050.10

**CRISP - Gabriel (CAT. D)**

Tessuto | Fabric | Tissu | Tejido



4032



4033



4021



4603



4731



4721



4752



4013



4125

**PEL**

**POLO - Anica (CAT. D)**

Pelle | Leather | Cuir | Cuero



0947



0826



0822



0845



0838

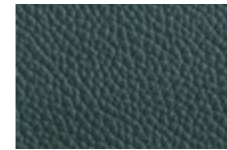

0832

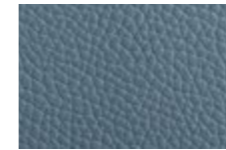

0878

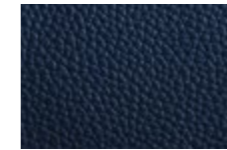

0856



0860

**EPX**

**Epossidico Mod. E10**

Epoxy | Époxy | Epoxi

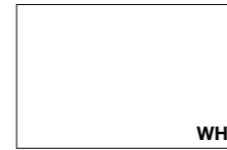

WHITE



SAND ROSE



WINE RED



NIGHT BLUE



ANTHRACITE



DEEP GREEN



BLACK

## Legenda simboli

Symbols key | Légende symboles | Leyenda signos

### STD

Standard  
Standard  
Standard  
Estandard



Su richiesta  
On request  
Sur demande  
A petición



Impilabilità  
Stackability  
Empilabilité  
Apilabilidad



Impilabilità su carrello porta sedie  
Stackability on chair trolley  
Empilabilité sur chariot porte-chaises  
Apilabilidad en carrito de sillas



100% riciclato  
100% recycled  
100% recyclé  
100% reciclado

### POL

Polipropilene  
Polypropylene  
Polypropylène  
Polipropileno

### RET

Rete  
Mesh  
Réseille  
Malla

### TES

Tessuto  
Fabric  
Tissu  
Tejido

### PEL

Pelle  
Leather  
Cuir  
Cuero

### EPX

Epossidico  
Epoxy  
Époxy  
Epoxi

**Le finiture contenute nella stampa sono puramente indicative e non sono di riferimento per le forniture del prodotto**  
Due to the printing process, finishes shown in this document are for illustration only. The finish on the final item may differ slightly from the printed illustration  
Les finitions contenues dans l'impression sont purement indicatives et ne sont pas pertinentes pour les fournitures du produit  
Los acabados contenidos en la impresión son puramente indicativos y no son de referencia para los suministros del producto

**Visual & graphic design**

Alea marketing + communication

AL/CACD/CG



alea  
aleaoffice.com



**GLOBAL HEADQUARTERS AND SHOWROOM** : Via Col de Rust, 19 - 33070 Sarone (PN) - Italia : Tel ++39 0434 777 333  
email: info@aleaoffice.com **PARIS SHOWROOM** : 176 Avenue Charles de Gaulle 92200, Neuilly-sur-Seine - France **NORTH AMERICAN  
HEADQUARTERS** : Midtown 2, 3449 NE 1st Avenue L-32, Miami, FL 33137 - USA : Tel ++1 305 470 1200 - email: info@alea-usa.com  
**ALEA UK OFFICE AND SHOWROOM** : 50-54 Clerkenwell Road, London EC1M 5PS - email: info@aleaoffice.com