

alea

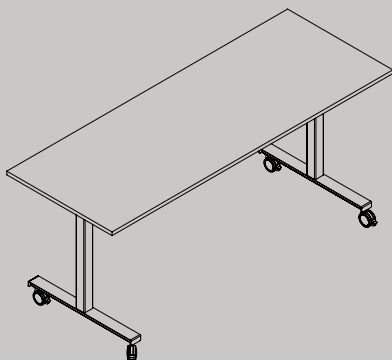

CLUB

complementi | complements | compléments | complementos

“ Vi presentiamo Club:
il nostro tavolo ribaltabile
multifunzionale ”

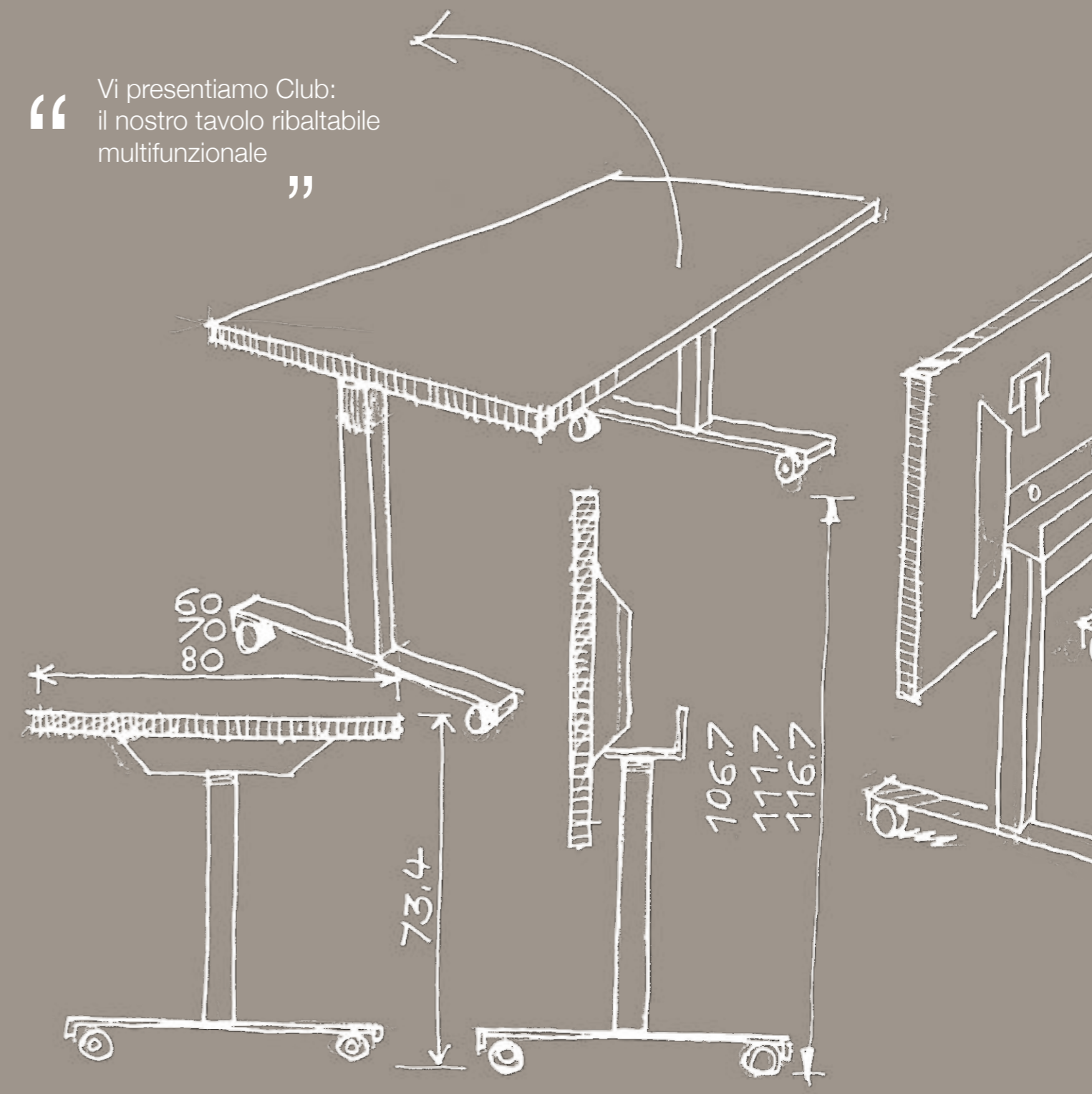

*Introducing Club:
our multifunctional folding table*

*Nous vous présentons Club:
la table rabattable multifonctionnelle*

*Les presentamos Club:
nuestra mesa plegable multifuncional*



Il tavolo Club con piano ribaltabile e struttura su ruote, è adatto ad arredare sale polifunzionali. Si compone di una struttura in alluminio estruso a sezione quadrata e piedi in lamiera d'acciaio, entrambi verniciati a polveri epossidiche in molteplici colori, e un top realizzato in melaminico spessore 30 mm. I tavoli possono essere facilmente spostati, piegati e stoccati quando necessario.

Club is a folding table on casters with many applications. It consists of an extruded aluminium structure with square section and steel feet, both painted with epoxy powder in many colours, and a top made of 30 mm (1 3/16") thick Italian melamine panel. Tables can be easily moved, folded and stored when needed.

La table Club avec plateau rabattable et mobile, s'adapte a' plusieurs configurations et solutions et convient aux salles polyvalentes. Sa structure en aluminium extrudé avec une section carrée et les pieds en tôle d'acier sont disponibles en finition époxy laqué en plusieurs couleurs. Son plateau en mélamine de 30 mm d'épaisseur a autant de finitions possibles. Ces table peuvent être facilement déplacés, pliées et stockées au besoin.

La mesa Club con el sobre plegable y la estructura sobre ruedas, es adecuada para salas polivalentes. Se compone de una estructura en aluminio extruido de sección cuadrada y pies en chapa de acero, ambos barnizados con polvos epoxi en varios colores, y un sobre superior realizado en melamina de 30 mm de espesor. Las mesas se pueden mover fácilmente, plegar y almacenar cuando sea necesario.

La parte delle ruote a contatto con il pavimento è in gomma. L'appoggio a terra consente un'ottima stabilità, adatta a qualsiasi tipo di pavimentazione, anche in tessuto, rispettando interamente le superfici. Le ruote montate dal lato operatore sono provviste di freno.



The part of the wheel in contact with the floor is made of rubber. The part that leans on the ground allows for excellent stability, suitable for any type of flooring including carpet, without ruining the floor. The wheels mounted on the operator side have a brake.

Les roulettes sont revêtus en caoutchouc. L'appui au sol permet une excellente stabilité, adapté à tout type de revêtement de sol, même en tissu, en respectant entièrement les surfaces. Les roues cote' operateur sont munies de frein.

La parte de las ruedas que lleva en contacto con el suelo está hecho de caucho. La parte que apoya en el suelo permite una excelente estabilidad, adecuado para cualquier tipo de suelo, incluso textil, respetando por completo las superficies. Las ruedas montadas en el lado del operador están equipadas con un freno.



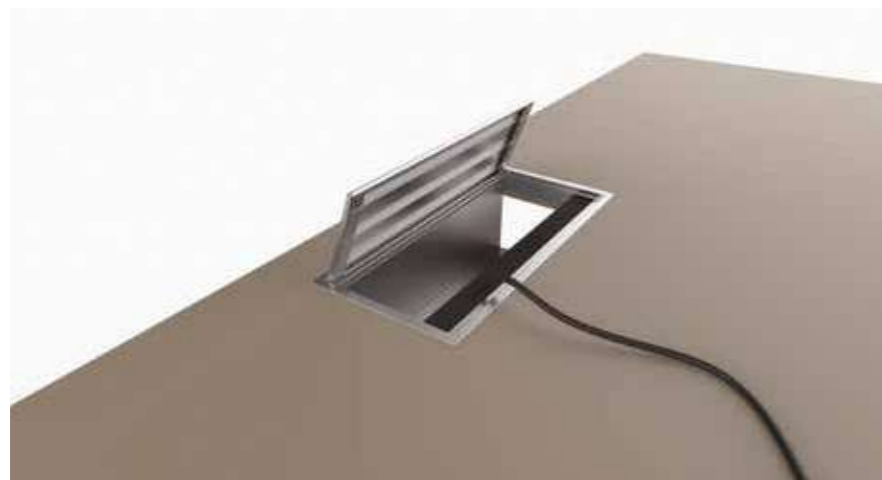

Ganging devices are used to connect the tables. The kit consists of two pairs of plastic parts installed below the worksurface with metric screws. Club tables can be equipped with PVC grommets of different sizes. When the table has a flip top, the door is in aluminum and carries a magnet to prevent it from opening when the table is placed in "parking" position.

For the electrification it is possible to use the structural beam which also acts as a cable carrier. Vertical electrification can be made with translucent polycarbonate vertebrae secured to the desk top or to the beam.

Pour connecter les tables en ligne les uns avec les autres des crochets en plastique sont appliqués à la partie supérieure; ceux-ci sont fixés sous la table de travail avec de vis métriques.

Les tables Club peuvent être équipées des passe câbles en PVC de différentes tailles et des tops accès modulaires en aluminium avec aimant pour éviter que ceux-ci ouvrent lorsque la table est placée en position "park".

Pour l'électrification, il est possible d'utiliser la poutre structurelle qui agit également comme passage des câbles en horizontal. L'électrification verticale peut être réalisée avec les vertèbres en polycarbonate translucide fixées au sol et à la poutre.

Per collegare in linea i tavoli tra loro vengono applicati al top degli appositi ganci realizzati in plastica che si fissano sotto al piano di lavoro tramite viti metriche. I tavoli Club possono essere dotati di passacavi in PVC di varie dimensioni e di top access modulari realizzati in alluminio con magnete di chiusura applicato allo sportello per evitare che questo si apra quando il tavolo viene posto in posizione di "parcheggio". Per l'elettrificazione è possibile sfruttare la trave strutturale che funge anche da portacavi. L'elettrificazione verticale può essere invece realizzata con vertebre in polycarbonato traslucido fissate ai piani o alla trave.

Para unir las mesas entre ellas en línea, se utilizan un par de ganchos de plástico que se fijan debajo de la mesa de trabajo a través de tornillos métricos. Todas las mesas Club pueden equiparse con pasacables en PVC de varios tamaños y de top access modulares realizados en aluminio con cierre magnético aplicado a la tapeta abatible para evitar que esta se abra cuando la mesa se coloca en la posición "aparcamiento". Para la electrificación es posible utilizar la viga estructural que permite también el pasaje de los cables. En cambio, la electrificación vertical puede realizarse con vértebras de polycarbonato translúcido fijadas al sobre de mesa o a la viga.



La struttura della scrivania è composta da due colonne verticali in alluminio estruso a sezione quadrata 50x50 mm, spessore 2 mm, con piedi in lamiera d'acciaio presso-piegata dello spessore 3 mm e trave strutturale in lamiera d'acciaio spessore 1,5 mm. La trave, che serve anche da canale portacavi, viene fissata alle colonne tramite dei giunti realizzati in pressofusione di zama mentre il piano è fissato alla struttura tramite staffe in lamiera d'acciaio presso-piegata dello spessore di 3 mm. La struttura è disponibile in vari colori epossidici. Le ruote, fissate ai piedi del tavolo, hanno un diametro di 60 mm ed una portata di 35 Kg ognuna.

The desk structure consists of two vertical extruded aluminum columns with a square section of 50x50 mm (2"x2"), 2 mm (1/16") thick, with steel feet 3 mm (2/16") thick and 1,5 mm (3/32") thick steel structure. The beam, which also serves as a wire channel, is secured to the columns via zamac die-casting joints while the desk top is fastened to the structure with 3 mm (2/16") thick steel brackets. The structure is available in various epoxy colors. The wheels have a diameter of 60 mm (2 6/16") and a weight limit of 35 Kg (77 lbs) each.



La structure de la table se compose de deux colonnes verticales d'aluminium extrudé avec une section carrée 50x50 mm, épaisseur 2 mm, avec des pieds en tôle d'acier pliée d'une épaisseur de 3 mm et une poutre de structure de tôle d'acier de 1,5 mm d'épaisseur. La poutre, qui sert aussi de passage des câbles, est fixé sur les pieds par de joints en zamak. Le plateau en revanche est fixé à la structure par des équerres en tôle d'acier, épaisseur de 3 mm. La structure est disponible en différentes couleurs époxy. Les roues, fixées au pied de la table, ont un diamètre de 60 mm et une capacité de 35 kg chacune.

La estructura de la mesa está compuesta por dos columnas verticales en aluminio extruido de sección cuadrada de 50x50 mm, espesor 2 mm, con los pies en chapa de acero plegada de 3 mm de espesor y una viga estructural en chapa de acero de 1,5 mm de espesor. La viga estructural que permite también el pasaje de los cables, se fija a las columnas por medio de articulaciones hechas de zinc, mientras que el sobre de mesa se fija a la estructura por medio de soportes en chapa de acero plegada de 3 mm de espesor. El marco está disponible en diferentes colores epoxi. Las ruedas, fijadas a los pies de la mesa, tienen un diámetro de 60 mm y una capacidad de 35 kg cada una.



Il modesty è realizzato in agglomerato ligneo spessore 18 mm nobilitato melaminico, con bordi perimetrali in ABS spessore 1 mm. Le staffe di supporto sono realizzate in lamiera d'acciaio e verniciate dello stesso colore della struttura e permettono la rotazione del modesty stesso quando il piano viene messo in posizione di "parcheggio".

Modesty panel is made of 18 mm (11/16") thick melamine-faced particle board, edged in 1 mm (1/32") ABS. The support brackets are made of steel and painted with the same finish as the structure and allow the modesty rotation when the desk top is in "parking" position.

Le voile de fond est réalisé en mélaminé épaisseur 18 mm, avec un chant en pvc épaisseur 1 mm. Les équerres sont en tôle d'acier, peint de la même couleur de la structure et permettent la rotation du voile de fond lorsque le plan est mis en position "park".

Faldón realizado en aglomerado de madera de 18 mm de espesor, con borde en ABS de 1 mm. Los soportes están hechos en chapa de acero y pintadas del mismo color de la estructura y permiten la rotación del faldón cuando el sobre de mesa se pone en posición de "aparcamiento".





/configurazione a U | U configuration
configuration U | configuración de U



/configurazione a V | V configuration
configuration V | configuración de V

Modulo elettrificato sul piano
Top power module
Module électrifié sur le plan de travail
Módulo electrificado en sobre mesa

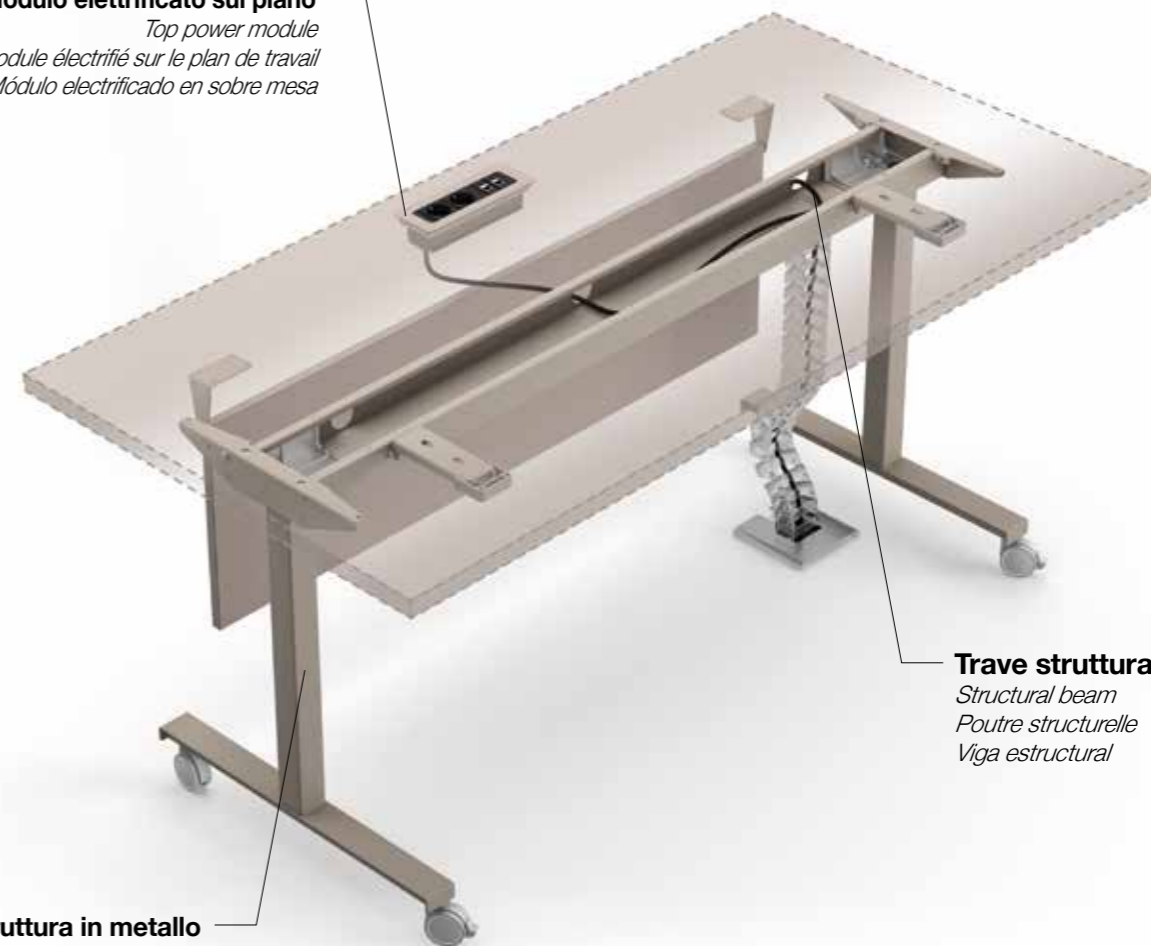

Trave strutturale
Structural beam
Poutre structurelle
Viga estructural

Struttura in metallo
Metal structure
Structure en métal
Estructura metálica



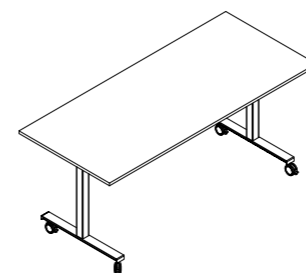













Scrivania singola | *single desk* | *bureau individuel* | *mesa individual*



	L 1200 47 4/16"	L 1400 55 2/16"	L 1600 63"	L 1800 70 14/16"		
P 600 23 10/16"	•	•	•	•		
P 700 27 9/16"	•	•	•	•		
P 800 31 8/16"	•	•	•	•		

MEL







Melaminico Italian melamine Melaminé Melaminico

 Bianco rigato Rippled effect white Blanc avec rayures Blanco rayado	 Grigio rigato Rippled effect grey Gris avec rayures Gris rayado	 Nichel Nickel Nickel Niquel	 Cacao Cocoa Cacao Cacao	 Bianco White Blanc Blanco	 Talco Talco Talco Talco
 Ocre Ochre Ocre Ocre	 Safari Safari Safari Safari	 Noisette Noisette Noisette Noisette	 Ardesia Ardesia Ardesia Pizarra	 Nero Black Noir Negro	 Rovere chiaro Light oak Chêne clair Roble claro
 Rovere americano American oak Chêne américain Roble americano	 Rovere grigio Grey oak Chêne gris Roble gris	 Rovere moro Dark oak Chêne foncé Roble oscuro	 Noce Canaletto Canaletto Walnut Noyer Canaletto Nogal Canaletto	 Noce scuro Dark walnut Noyer foncé Nogal oscuro	

Piano
Top
Plateau
Sobre



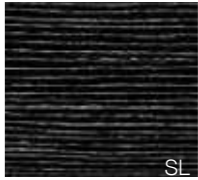

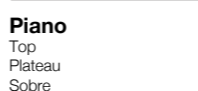





LGN

Legno Wood Bois Madera

 Rovere chiaro Light oak Chêne clair Roble claro	 Rovere grigio fumo Smoke grey oak Chêne gris de fumée Roble gris humo	 Rovere moro Dark oak Chêne foncé Roble oscuro	 Noce Canaletto Canaletto walnut Noyer Canaletto Nogal Canaletto	 Ebano silver Silver ebony Ebony silver Ebano plata	 Ebano Makassar Makassar ebony Ebony Makassar Ebano Makassar
 Noce termocotto Heat-treated walnut Noyer thermo traité Nogal termotratado					
 Piano Top Plateau Sobre					

EPX

Epossidico Epoxy Epoxyde Epoxídico

 Bianco White Blanc Blanco	 Talco Talco Talco Talco	 Grigio Grey Gris Gris	 Sabbia Cream Sable Arena	 Noisette Noisette Noisette Noisette	 Ardesia Ardesia Ardesia Pizarra
 Verde Oliva Olive green Olive vert verde oliva	 Oro Gold Or Oro	 Rame Copper Cuivre Cobre	 Bronzo Bronze Bronze Bronce	 Nero Black Noir Negro	

Struttura
Structure
Structure
Estructura

- Le finiture contenute nel presente catalogo sono puramente indicative e non sono di riferimento per le forniture del prodotto.
- The finishes shown in this catalogue are for illustration purpose only. The finishes on the physical product may slightly differ from the printed illustration.
- Les finitions contenues dans ce catalogue ne sont pas contractuelles - les photos ne pouvant rendre la parfaite réalité.
- Los acabados contenidos en este catálogo son puramente indicativos y no son de referencia para los suministros del producto.

ecologia

Alea utilizza per i suoi prodotti e i suoi imballi materiali facilmente separabili e riciclabili.

attestazione di prodotto

I prodotti Alea sono stati sottoposti a prove prestazionali presso laboratori di prova accreditati. Copia dei rapporti di prova o delle attestazioni di conformità sono disponibili su richiesta. I prodotti Alea soddisfano i requisiti LEED per il credito IEQ4.5 per i materiali a bassa emissione ed i requisiti ANSI/BIFMA X7.1-2011. Alea dichiara di utilizzare pannelli a base di legno aventi un rilascio di formaldeide conforme alla classe E1 secondo il DM 10/10/2008. Alea si impegna inoltre ad utilizzare materiali legnosi FSC e pannelli a base di legno con certificazione CARB2.

environment

Alea products and packaging are made of recyclable materials.

product certification

Alea products have been subjected to performance tests at accredited testing laboratories. Copies of test reports or certificates of conformity are available on request. Alea products meet the LEED requirements for IEQ4.5 credit for low emission materials and the ANSI/BIFMA X7.1-2011 requirements. Alea declares to use wood-based panels with a formaldehyde release according to class E1 according to DM 10/10/2008. Alea also undertakes to use FSC wood-based materials and CARB2-certified wood-based panels.

environnement

Alea utilise des matériaux facilement séparables et recyclables pour ses produits et ses emballages.

certification de produits

Les produits Alea ont été soumis à des tests de performance dans des laboratoires accrédités. Des copies des rapports d'essais ou des certificats de conformité sont disponibles sur demande. Les produits Alea répondent aux exigences LEED pour le crédit IEQ4.5 pour les matériaux à faibles émissions et aux exigences ANSI/BIFMA X7.1-2011. Alea déclare utiliser des panneaux à base de bois avec un dégagement de formaldéhyde selon la classe E1 selon DM 10/10/2008. Alea s'engage également à utiliser des matériaux à base de bois FSC et des panneaux à base de bois certifiés CARB2.

ecología

Alea utiliza productos y embalajes en materiales fácilmente separables y reciclables.

certificación de producto

Los productos Alea han sido sometidos a pruebas de rendimiento en laboratorios de pruebas acreditados. Copias de los informes de las pruebas o certificados de conformidad están disponibles bajo petición. Los productos Alea cumplen con los requisitos LEED para el crédito IEQ4.5 para materiales de baja emisión y los requisitos ANSI/BIFMA X7.1-2011. Alea declara utilizar paneles de madera con una emisión de formaldehído según la clase E1 según DM 10/10/2008. Alea también se compromete a utilizar materiales a base de madera FSC y paneles a base de madera certificados por CARB2.

concept & design

Alea marketing + communication

design

Filippon

art direction

Mirto Antonel

AI/CABL/AD



GLOBAL HEADQUARTERS AND SHOWROOM : Via Col de Rust, 19 - 33070 Sarone (PN) - Italia : Tel ++39 0434 777 333
email: info@aleaoffice.com **PARIS SHOWROOM** : 176 Avenue Charles de Gaulle 92200, Neuilly-sur-Seine - France **NORTH AMERICAN**
HEADQUARTERS : Midtown 2, 3449 NE 1st Avenue L-32, Miami, FL 33137 - USA : Tel ++1 305 470 1200 - email: info@alea-usa.com
ALEA UK OFFICE AND SHOWROOM : 50-54 Clerkenwell Road, London EC1M 5PS - email: info@aleaoffice.com