



100%
MADE
IN
ITALY

complementi
→ complemets

TAGLIOSESSANTA
by MARONESE ACF



^{IT} I complementi completano l'arredamento e gli ambienti della casa. Madie, librerie, tavoli, sedie e poltrone, ma anche mensole, specchiere e carte da parati: ogni elemento contribuisce allo stile e alla funzionalità degli spazi in cui viviamo. Dal living alla camera da letto, arredi e oggetti comunicano tra di loro e danno personalità alla casa.

^{EN} Design accessories are the finishing touches of home interiors. Sideboards, bookcases, tables, chairs and armchairs..., but also shelves, mirrors and wallpaper: every element adds to the style and functionality of the spaces where we live. From the living room to the bedroom, objects and accessories communicate with each other and add character to the home.

Complements

2020

Madie | Sideboards → 05

Librerie | Bookcases → 101 Tavoli | Tables → 113

Sedie | Chairs → 255 Poltrone & Pouf | Armchairs & Poufs → 291

Tavolini | Coffee tables → 313 Accessories | Accessories → 345

i Classici | the Classics → 397 Wallpaper → 407

Finiture & Maniglie | Finishes & Handles → 413

Sideboards
↓

UN MOBILE
DEL PASSATO
CHE ARREDA
SPAZI
MODERNI.

A history of complementing modern spaces.

Madie

Tanti modelli per dare stile
ad ogni ambiente.
A choice of models to bring
style to any room.

index

07	→	Setaplus / Seta
35	→	Laila
49	→	Cover
57	→	Aura Line
61	→	Aura Glass
65	→	Frida
71	→	Tai
73	→	Gilda
79	→	Monic
87	→	Olimpia
89	→	Giava
91	→	Fanny
95	→	Scuderia

Sideboard **Setapuls**



MADIA SETAPULS ↑

→
Setapuls SA2017
 L 2114 x H 962 x P 390 mm

Laccato opaco / Matt lacquered
 Grafite

Melaminico Marmo / Marble Melamine
 Nero Marquinia

Mensola a "ELLE"
 Melaminico Marmo / Marble Melamine
 Nero Marquinia



EFFETTO MARMO

IT La trasparenza del vetro, le venature del marmo e le luci interne danno forma ad una madia elegante e scenografica.

EN Transparent glass, marble markings and interior lights give form to an elegant and eye-catching sideboard..

Marble effect ↑



Setaplus SA2017
L 2114 x H 786 x P 398 mm

Melaminico Colore / Colour Melamine
Grafite

Telaio brunito con vetro fumè /
Burnished frame with fumè glass



**Seta SA1621**

L 2114 x H 1056 x P 398 mm

Melaminico Colore / Colour Melamine

Grafite

Telaio brunito con vetro fumè /

Burnished frame with fumè glass

**ANTA TELAIIO VETRO**

IT Il tutto vetro caratterizza la madia sospesa: l'effetto fumè è raffinato e, anche se i volumi sono importanti, l'arredo è leggero.

EN Glass is the name of the game with this floating sideboard: the smoky effect is refined and, despite its large dimensions, provides a sense of lightness.

Glass framed door
↑



Setaplus SA2018
L 2114 x H 892 x P 492 mm

Melaminico Rovere / Oak Melamine
Thea

Laccato opaco / Matt lacquered
Nichel





VASSOIO IN METALLO

IT Nella parte superiore, un elemento valorizza il design della sedia: il vassoio con mensola integrata e finitura a contrasto.

EN The upper section features an element that enhances the sideboard's design: a tray with built-in shelf and contrasting finish.

Metal tray ↑



Setaplus SA2021
L 1762 x H 892 x P 492 mm

Melaminico Colore / Colour Melamine
Bianco - Ghiaccio - Titanio

Melaminico Marmo / Marble Melamine
Calcata



MADIA SETAPLUS
↑

VARIETÀ DI FINITURE E COLORI

^{IT} L'effetto marmo è abbinato a tonalità chiare in gradazione per una madia dall'aspetto variegato, ma non troppo.

^{EN} The marble effect is matched with light tones for a sideboard that is multi-coloured, but only just.

Variety of finishes and colours
↑



MADIA SETAPLUS
↑



YANO A GIORNO

IT Con l'inserimento di un vano a giorno, la madia apre un piccolo spazio al suo interno e aggiunge un tocco di colore.

EN The inclusion of an open compartment provides a small aperture into the interior and adds a touch of colour.

Open compartment ↑



Seta SA1612
L 1762 x H 892 x P 492 mm

Melaminico Frassino / Ash Melamine
Juta

Rovere Nodato / Knotted Oak

Laccato opaco / Matt lacquered
Geranio



MADIA SETA ↑



Setaplus SA1601
L 2114 x H 892 x P 492 mm

Laccato opaco / Matt lacquered
Porpora

Melaminico Olmo / Elm Melamine
Grigio



MADIA SETAPLUS
↑

DOPPIO SPESSORE

^{IT} I frontali sono caratterizzati da un doppio spessore che dà dinamismo e ritmo alla madia monocromatica.

^{EN} The front panels have double thickness to bring dynamism and rhythm to this monochromatic sideboard.

Double thickness ↑



MADIA SETAPLUS ↑



Setaplus SA2014
L 2114 x H 716 x P 492 mm

Laccato lucido / Glossy lacquered
Ghiaccio

Melaminico Rovere / Oak Melamine
Thea

Laccato opaco / Matt lacquered
Bronzo

MADIA SETAPLUS ↑



Setaplus SA2020
L 1762 x H 716 x P 500 mm

Laccato opaco / Matt lacquered
Agata



→

^{IT} Nel design di una madia, gli spazi pieni e gli spazi vuoti si alternano per alleggerire i volumi importanti o semplicemente per movimentare l'estetica dell'arredo. I vani a giorno non hanno ante e quindi sono aperti per contenere e, allo stesso tempo, esporre libri o altri oggetti decorativi.

^{EN} In the design of a sideboard, there is an alternation of full spaces and empty spaces which add lightness to large dimensions or, simply, create excitement. Compartments are left open to display books or other decorative items.



↑ **Laccato opaco / Matt lacquered**
Agata

→

SA1616 (sx)
L 1058 x H 1244 x P 401 mm

Laccato opaco / Matt lacquered
Grigio Pietra - Ghiaccio

SA1617 (dx)
L 1058 x H 1244 x P 401 mm

Laccato opaco / Matt lacquered
Ghiaccio - Verde Oliva



MADIA SETA ↑

→
Laila LA001
L 2136 x H 766 x P 537 mm

Laccato opaco / Matt lacquered
Bianco

Melaminico Rovere / Oak Melamine
Avena

Melaminico Marmo / Marble Melamine
Calacatta



Sideboard **Laila**



MADIA LAILA ↑



IT La madia è un vero e proprio arredo, che all'interno di un living può fare la differenza. Gli abbinamenti di materiali diversi creano combinazioni uniche e originali. Le possibilità di personalizzazione sono tante: venature, effetti marmo e colori si mixano, così madia mostra la sua personalità.

EN Sideboards are items of furniture that can make a huge difference to living spaces. Combinations of different materials create unique and original compositions. There are numerous ways to personalise them: grains, marble effects and colours blend to give each sideboard its own personality.



MADIA LAILA ↑

↑ **Melaminico Marmo / Marble Melamine**
Calacatta

Laila LA003 (sx)
L 904 x H 1374 x P 435 mm

Laila LA004 (dx)
L 1080 x H 1374 x P 435 mm

Melaminico Rovere / Oak Melamine
Avena

Melaminico Colore / Colour Melamine
Grafite

Laccato opaco / Matt lacquered
Magma



MADIA LAILA



Laila LA006
L 2136 x H 836 x P 537 mm

Melaminico Rovere / Oak Melamine
Thea

Melaminico Marmo / Marble Melamine
Ash Stone



MADIA LAILA ↑



SCOCCA SPORGENTE

IT I frontali rientrano leggermente rispetto alla base e ai fianchi: la struttura crea una cornice che racchiude l'estetica della madia.

EN The fronts are slightly further back than the base and sides: the structure frames the sideboard's aesthetic.

Protruding structure
↑

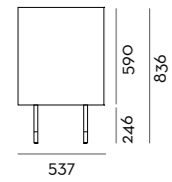

Laila LA005

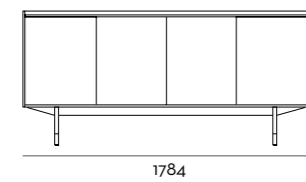

Laila LA006

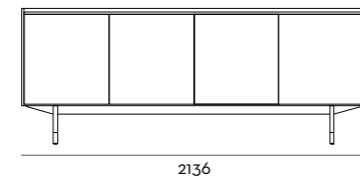

MADIA LAILA
↑



Laila LA007
L 1784 x H 942 x P 537 mm

Melaminico Colore / Colour Melamine
Titanio

Melaminico Marmo / Marble Melamine
Nero Marquinia



MADIA LAILA
↑



BASAMENTO CON PIEDINI

^{IT} I piedini sottili sostengono la madia e, allo stesso tempo, con il loro design contribuiscono all'eleganza d'insieme dell'arredo.

^{EN} The slim feet support the sideboard, while their design contributes to the overall elegance of the piece.

Base unit with feet ↑

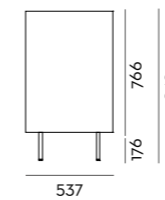

Laila LA007

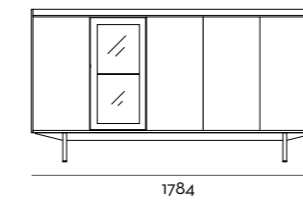

Laila LA008

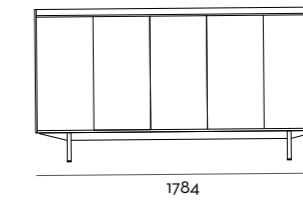

Sideboard **Cover**



Cover CV002
L 2216 x H 788 x P 492 mm

Laccato opaco / Matt lacquered
Verde Palude



MADIA COVER
↑



ANGOLI ARROTONDATI

IT Con le sue forme morbide, il colore tenue e i piedini dorati la madia rievoca il design degli anni Settanta per uno stile retrò.

EN With its gentle contours, soft tones and gold feet this sideboard evokes 1970s design for vintage style.

Rounded corners ↑

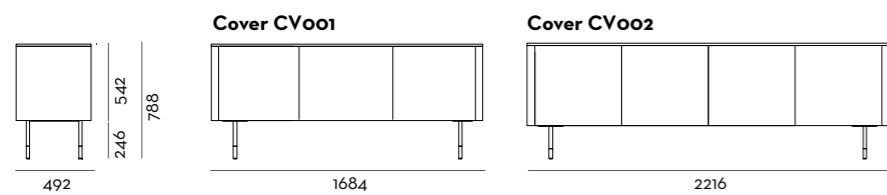

MADIA COVER ↑



Cover CV002
L 2216 x H 788 x P 492 mm

Frassino Laccato / Lacquered Ash
Juta

Top Ecopelle / Eco-leather top
Gold 04

MADIA COVER
↑



MANIGLIA DECORATIVA

IT La maniglia è suddivisa in due parti e diventa pezzo unico quando le ante sono chiuse. Un dettaglio che impreziosisce la madia.

EN The handle is divided into two parts which join to become one when the doors are closed. A detail that lifts the aesthetic of the sideboard.

Decorative handle
↑



MADIA C OVER
↑



Aura Line ALOO1
L 1760 x H 812 x P 488 mm

Melaminico Rovere / Oak Melamine
Thea

Melaminico Marmo / Marble Melamine
Calacatta



Sideboard **Aura Line**





RIPIANO IN VETRO

IT Quando è chiusa, l'anta lascia aperto uno spazio e mette in luce gli oggetti che contiene. Il ripiano in vetro dà eleganza.

EN When it is closed, the door leaves open space and shows off the objects inside it. The glass shelf provides elegance.

Glass shelf ↑

Aura Line ALO01

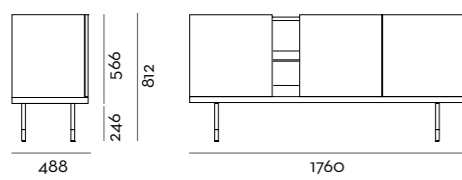

Aura Line ALO02

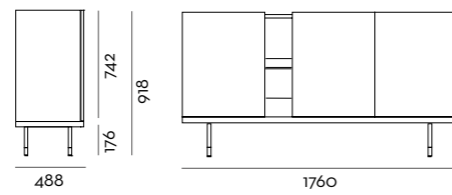

MADIA AURA LINE ↑



Aura Glass AG001
L 1760 x H 812 x P 488 mm

Laccato opaco / Matt lacquered
Verde Palude

Vetro satinato laccato / Lacquered satin glass
Verde Palude

Sideboard **Aura Glass**



INSERTI IN VETRO COLORATO

^{IT} Con la sua texture tridimensionale, gli inserti in vetro satinato, colorato e "millerighe" decorano i frontali della madia.

^{EN} With its three-dimensional texture, satin-finish glass inserts, colourful and with a rib effect, grace the fronts of these sideboards.

Coloured glass inserts ↑

Aura Glass AG001

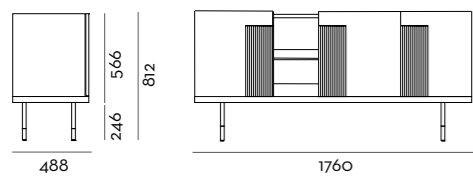

Aura Glass AG002

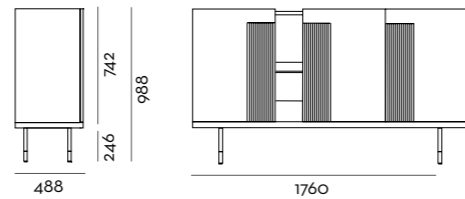

MADIA AURA GLASS ↑



Frida FGo03
L 2112 x H 774 x P 487 mm

Laccato opaco / Matt lacquered
Cipria

Vetro satinato laccato / Lacquered satin glass
Cipria

Sideboard **Frida**





MANIGLIA APPLICATA

IT La maniglia tono su tono è un elemento funzionale, che crea delle linee sottili e decorative sull'arredo.

EN The tone-on-tone handle is a functional element that creates fine decorative lines.

Mounted handle ↑

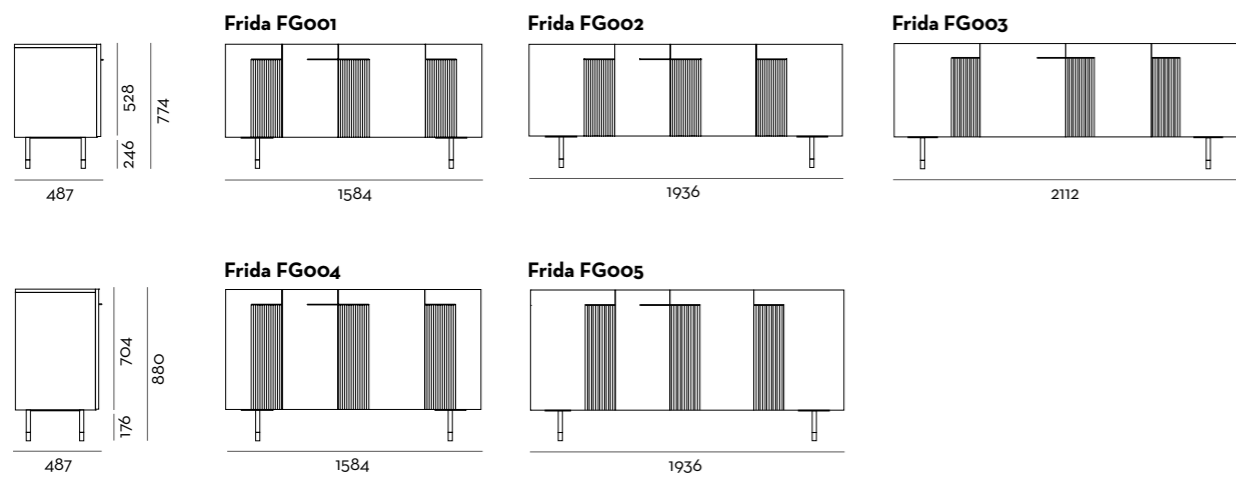

MADIA FRIDA ↑

→
Frida FGO05
L 1936 x H 880 x P 487 mm

Laccato opaco / Matt lacquered
Terranova - Bronzo



MADIA FRIDA
↑



Tai TA001
L 1800 x H 776 x P 480 mm

Laccato opaco / Matt lacquered
Bianco

MADIA TAI
↑



Sideboard **Tai**

FRONTALE DECORATO

^{IT} Il design crea sulla superficie un disegno che attraversa il frontale e suddivide in modo originale i cassetti della madia.

^{EN} The front design of the sideboard features playful partitioning of the drawers.

Decorated front
↑

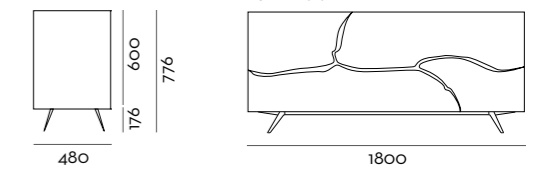

Sideboard **Gilda**



Gilda GLOO2
L 1760 x H 880 x P 487 mm

Melaminico Colore / Colour Melamine
Bianco

Rovere / Oak
Nodato



→ ^{IT} Le linee e le geometrie semplici degli arredi possono essere valorizzate dalla scelta e dall'accostamento di particolari materiali, ma anche dall'inserimento di dettagli, come ad esempio gli inserti. Colorati, in legno, effetto marmo o in altre finiture, gli inserti decorano le superfici con discrezione.

^{EN} Simple lines and geometries can enhance the choice and combination of materials, but also the inclusion of certain details such as inserts. Colour, wood, marble graining or other finishes help inserts bring nuanced style to surfaces.

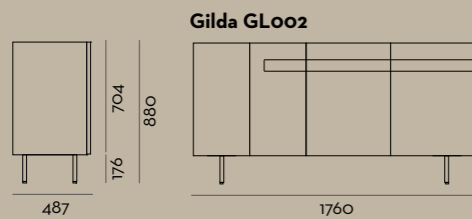

MADIA GILDA ↑

↑ **Inserto Rovere Nodato /**
Knotted oak insert



TOP E INSERTO ABBINATI

IT Un inserto decorativo richiama la finitura effetto marmo del top e corre con continuità lungo le ante e sul fianco.

EN A decorative insert is a nod to the marble effect finish of the top and runs along the horizontal length of the doors and side.

Coordinated top and insert
↑

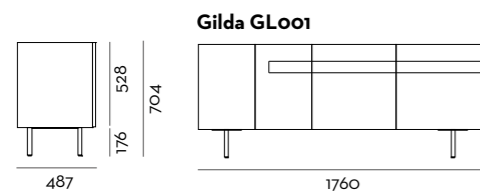

MADIA GILDA
↑



Gilda GL001
L 1760 x H 704 x P 487 mm

Melaminico Colore / Colour Melamine
Ghiaccio

Melaminico Marmo / Marble Melamine
Nero Marquinia

Sideboard **Monic**



Monic MC002
L 900 x H 1676 x P 400 mm
Rovere / Oak
Vero



MADIA MONIC ↑

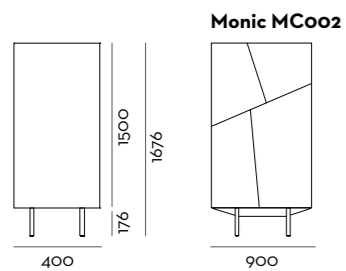



Monic MCO01
L 1850 x H 675 x P 505 mm

Rovere / Oak
Vero



MADIA MONIC
↑

CASSETTI SAGOMATI

IT I cassetti hanno particolari tagli obliqui, che caratterizzano il design della madia anche quando sono chiusi.

EN The striking feature of this sideboard is the oblique cut of its drawers.

Contoured drawers ↑



MADIA MONIC ↑

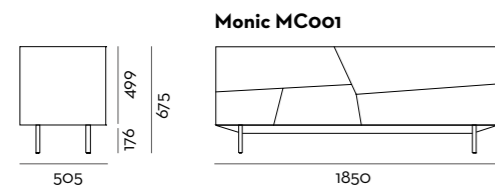

Monic MCOOT

→

IT Una madia interamente in legno è perfetta per essere inserita in ambienti dal gusto autentico e naturale. La matericità diventa la sua caratteristica principale: abbinata ad altri arredi in legno o dalle tonalità chiare e dal design essenziale, evoca uno stile nordico di grande tendenza.

EN A sideboard made entirely of wood looks perfect in any warm, natural setting. Texture is its main characteristic: combined with other wooden furniture or with clear tones and essential design lines, it is reminiscent of much sought-after Nordic style.



MADIA MONIC ↑

↑ **Rovere / Oak**
Vero



Olimpia OLO01
L 1800 x H 776 x P 475 mm

Rovere / Oak
Vero

Melaminico Marmo / Marble Melamine
Nero Marquinia

Sideboard **Olimpia**





MADIA OLIMPIA

Sideboard **Giava**



SPAZI ORGANIZZATI

^{IT} La madia è disponibile a tre o a quattro ante per adattarsi a tutte le esigenze di spazio, di contenimento e di stile.

^{EN} The sideboard is available with three or four doors to satisfy all storage, space and style needs.

Organised spaces ↑



Giava GV001
L 2400 x H 846 x P 475 mm

Rovere / Oak
Vero

Laccato opaco / Matt lacquered
Cotto

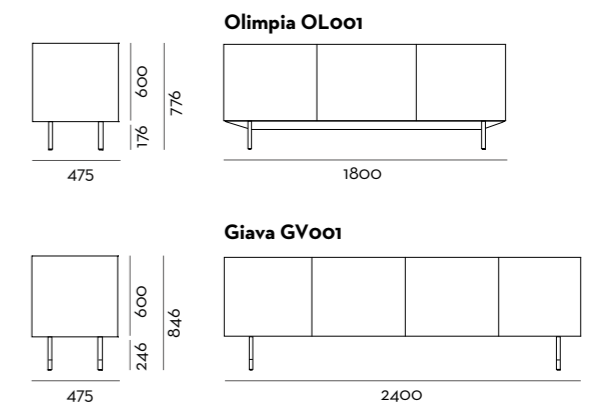

Sideboard **Fanny**



Fanny FY001
L 1852 x H 865 x P 450 mm

Rovere / Oak
Vero

Rovere / Oak
Decor Vintage





FINITURA DECOR

^{IT} La madia sembra una scacchiera: riquadri in diverse tonalità decorano le ante e i cassetti con un effetto vintage.

^{EN} The different shades of the squares decorating the doors and drawers of this sideboard give it a chessboard look and vintage style.

Decor finish ↑

MADIA FANNY ↑

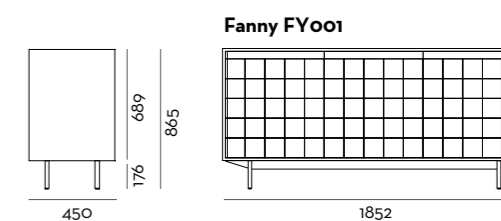

Sideboard **Scuderia**



MADIA SCUDERIA ↑



Scuderia M9165
L 2308 x H 735 x P 500 mm

Rovere / Oak
Natural

Laccato opaco / Matt lacquered
Bianco



DOGHE IN LEGNO

^{IT} La madia bianca è valorizzata da doghe dalla forma irregolare: un effetto decorativo che continua sul fianco lavorato.

^{EN} White sideboard bedecked with unevenly shaped slats for a decorative effect that extends to the side.

Wooden slats
↑

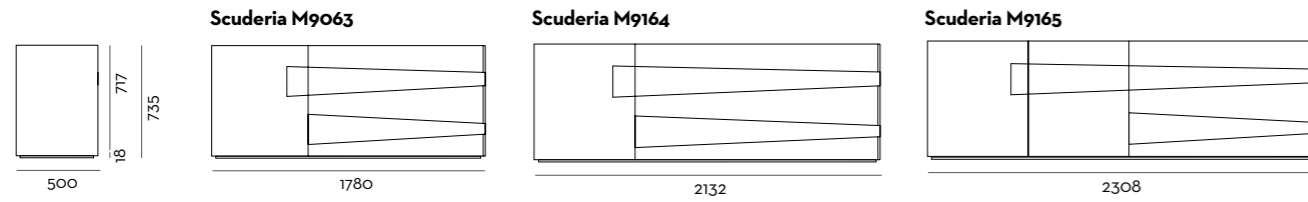

MADIA SCUDERIA
↑



Scuderia M9162
L 2132 x H 636 x P 500 mm

Rovere / Oak
Natural

Laccato opaco / Matt lacquered
Bianco

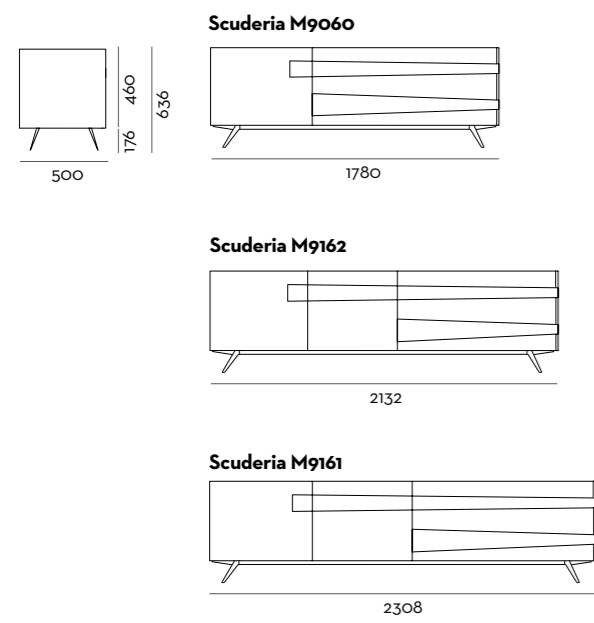

MADIA SCUDERIA ↑

Bookcases
↓

PRATICHE
PER
CONTENERE
E PERFETTE
PER ARREDARE
IL LIVING.

Practical storage perfect for living spaces.

Librerie

A terra o sospese, le
librerie hanno una grande
funzionalità.
Whether standing or
floating, bookcases provide
great functionality.

index

103 → Seta

109 → Kora

Bookcase **Seta**



Seta SA1554 (sx)
L 1270 x P 398 mm

Laccato opaco / Matt lacquered
Ghiaccio - Verde Oliva

Melaminico Olmo / Elm Melamine
Grigio

Seta SA1555 (dx)
L 1270 x P 398 mm

Laccato opaco / Matt lacquered
Grigio Pietra - Ghiaccio - Verde Oliva

Melaminico Olmo / Elm Melamine
Grigio



↑ Libreria sospesa Seta /
Seta floating bookcase



^{IT} Le librerie sospese reinterpretano l'arredo più caratteristico della zona giorno con originalità: visivamente leggere e dal volume più contenuto rispetto alle librerie tradizionali, trovano posto anche nelle pareti meno ampie. Una soluzione per portare stile e funzionalità nei piccoli spazi.

^{EN} Floating bookcases redefine the living area. Light on the eye and more compact than traditional bookcases, a place can be found for one even on smaller walls. A solution that brings style and functionality to where space is limited.

Bookcase **Seta**

SCHIENE COLORATE

^{IT} La libreria è vivacizzata dalle schiene colorate, che fanno da sfondo agli oggetti in primo piano e li mettono in risalto.

^{EN} The bookcase has lively back panels that set off the objects in the foreground.

Coloured back panels ↑



Seta SA1563
L 1094 x H 2150 x P 362 mm

Laccato opaco / Matt lacquered
Iguana

Melaminico Frassino / Ash Melamine
Juta



Bookcase **Kora**

STILE INDUSTRIALE

^{IT} Legno e metallo sono i materiali perfetti per dare forma a una libreria che si inserisce in ambienti dal mood industriale.

^{EN} Wood and metal are the perfect materials in a bookcase with an industrial mood.

Industrial style
↑



Kora KO003
L 2336 x H 2018 x P 362 mm

Rovere / Oak
Vero

Metallo / Metal
Nero opaco





DIVISORI IN METALLO

^{IT} Sottili lastre di metallo dividono e organizzano lo spazio all'interno della libreria, con uno stile originale.

^{EN} Thin sheets of metal divide and organise space in this original bookcase.

Metal dividers
↑

Bookcase **Kora**



Tables ↓

ARREDI MA
SOPRATTUTTO
LUOGHI
ATTORNO
AI QUALI
RITROVARSI.

Furniture but above all a place to meet.

Tavoli

Diverse forme, più materiali
e tanti stili da portare in tavola.
Various forms, different materials
and so many style opportunities
to bring to the table.

index

- 115 → Delta
- 123 → Radius
- 133 → Quid
- 141 → Triade
- 147 → Run
- 153 → Gelius
- 157 → Cleo
- 163 → Felix
- 169 → Poker
- 177 → Fix
- 183 → Venus
- 189 → Spring
- 195 → Planet
- 199 → Club
- 203 → Drop
- 209 → Taiga
- 219 → Strong
- 221 → Dafne
- 233 → Royal
- 239 → Prisma
- 245 → Mikado
- 251 → Icaro

Table Delta

Tavolo rettangolare allungabile

Extendable rectangular table ↑

IT L'essenza del tavolo si esprime attraverso una struttura sottile e quattro diverse tonalità, per ambienti dal gusto naturale o più moderno. Le allunghe laterali estendono lo stile e la convivialità.

EN The essence of this table is played out in a slim frame and four different colour tones for natural or modern settings. The side extensions provide more scope for style and conviviality.

DIMENSIONI dimensions

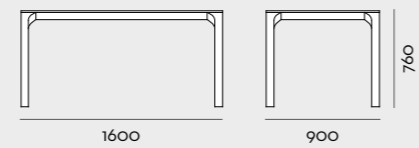

2 allunghe laterali 2 side extension panels

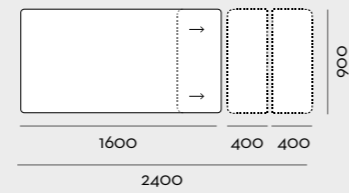

PIANO - STRUTTURA top - frame

Frassino Ash

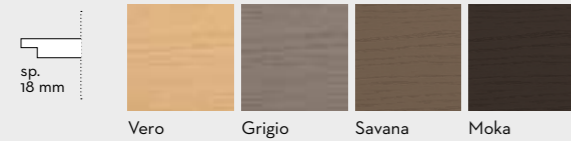

Frassino colore laccato in tutti i colori della mazzetta
Colour lacquered ash all the sample colours





Tvaoio Delta
L 1600/2400 x L 900 x H 760 mm
Frassino / Ash
Moka



ALLUNGHE LATERALI

^{IT} Il tavolo si estende oltre le misure standard attraverso un sistema di allunghe inserite sul lato del piano.

^{EN} The table extends beyond standard measurements thanks to panels inserted beneath the table top.

Side extension panels
↑



→

IT Le venature sottili caratterizzano sia la struttura sia il piano del tavolo: tutti gli elementi condividono la stessa finitura e la stessa tonalità. Un arredo che punta all'essenzialità della materia e che si adatta ad ogni tipologia di spazio, nella sostanza ma anche nella forma allungabile.

EN Both frame and table top feature fine grain lines: all elements share the same finish and the same colour tone. Furniture marked by essential materials, suited to all types of space providing convenience in both standard and extended formats.



↑ Frassino / Ash
Moka

Table Radius

Tavolo rettangolare fisso

Fixed rectangular table ↑

IT La struttura in essenza è disponibile in quattro diverse tonalità e può essere abbinata a piani in essenza, effetti marmo e cemento, colori laccati o gres per una grande personalizzazione.

EN The wood frame is available in four different tones and can be personalised with a wood, marble effect or concrete top, with coloured lacquer or stoneware finish.

DIMENSIONI dimensions

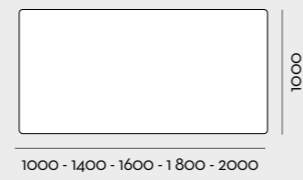
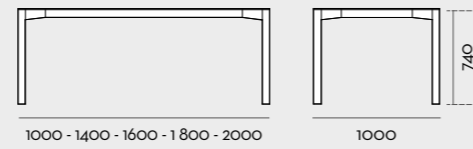

PIANO top

Melaminici Melamine

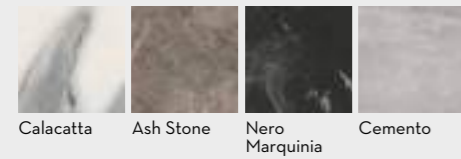

Laccati opachi in tutti i colori della mazzetta
Matt colour lacquered all the sample colours

Ceramica gres Stoneware

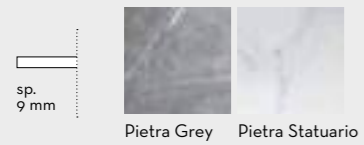

STRUTTURA frame

Frassino Ash

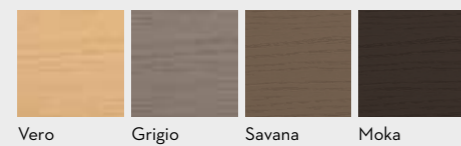

Laccati opachi in tutti i colori della mazzetta
Matt colour lacquered all the sample colours



Laccato opaco / Matt lacquered
Verde Palude

Tavolo Radius
L 2000 x L 1000 x H 752 mm

→

^{IT} Il tavolo colorato in laccato è molto attuale: la superficie risulta liscia ed omogenea, alla vista e al tatto. Il colore pieno è una scelta indicata per ambienti moderni, che possono essere sale da pranzo domestiche ma anche spazi di lavoro. Il colore può essere abbinato al resto dell'arredo o a contrasto.

^{EN} The colourful lacquer table is very modern with a surface that is even and smooth to the touch and to the eye. Solid colours are suited to modern settings, be it a dining room in the home or a space in the workplace. Colours can be matched or contrasted with the rest of the interior.



↑ **Laccato opaco / Matt lacquered**
Verde Palude

PIANO MATERICO

^{IT} Il tavolo è al centro della stanza e dell'attenzione, grazie alla matericità del piano in gres che lo rende elegante.

^{EN} The table is the focal point of the room, thanks to the texture of its elegant stoneware top that.

Textured top
↑



→

Tavolo Radius
L 2000 x L 1000 x H 750 mm

Ceramica Gres / Stoneware
Pietra Grey

Frassino / Ash
Moka

PIANO SOTTILE

^{IT} Le snelle gambe a cilindro sostengono un piano sottile: insieme danno forma un tavolo minimal ma ricercato nelle finiture.

^{EN} Slender cylindrical legs support a slim top: together they form a minimalist table with refined finish.

Slim top
↑





Tavolo Radius
L 2000 x L 1000 x H 752 mm

Melaminico Marmo / Marble Melamine
Calacatta

Frassino / Ash
Savana

Table Quid

Tavolo ovale fisso

IT Il tavolo è caratterizzato dalle gambe inclinate e dal piano con angoli arrotondati. La struttura in essenza può essere abbinata al piano nello stesso materiale oppure effetto marmo.

EN Table with sloping legs and top with rounded corners. The wood frame can be combined with a top in the same material or with a marble effect finish.

Oval fixed table ↑

DIMENSIONI dimensions

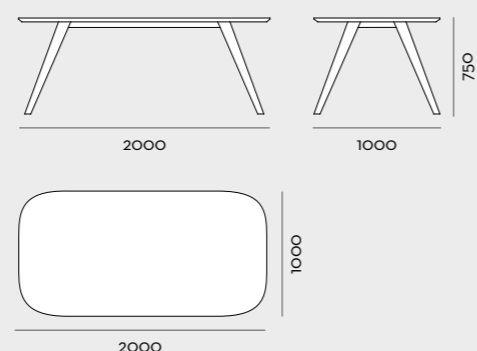

PIANO top

Melaminici Melamine

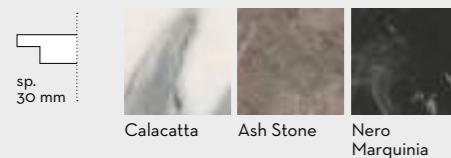

Frassino Ash

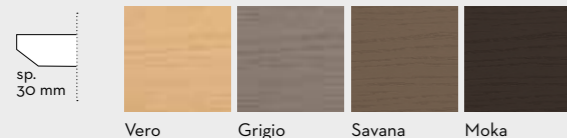

STRUTTURA frame

Frassino Ash

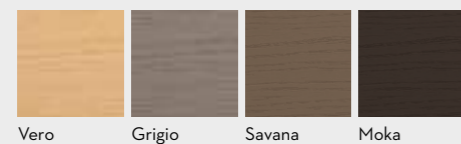

Frassino / Ash
Avena

Melaminico Marmo / Marble Melamine
Ash Stone

Tavolo Quid
L 2000 x L 1000 x H 750 mm

ANGOLI ARROTONDATI

^{IT} La matericità del piano viene ammorbidita dagli angoli arrotondati, che conferiscono al tavolo un aspetto delicato.

^{EN} The texture of the top is softened by the rounded corners, giving the table a delicate air.

Rounded corners ↑





←
Tavolo Quid
L 2000 x L 1000 x H 750 mm

Frassino / Ash
Moka



↑ **Frassino / Ash**
Moka



IT Gli angoli smussati sono un dettaglio di tendenza, perfetto per chi vuole un tavolo originale ma senza eccessi, per chi cerca un design diverso ma non troppo. Nei progetti d'interni, le forme arrotondate sono sempre eleganti e si prestano ad arredare sale da pranzo moderne e ricercate.

EN Rounded corners are an on-trend detail, perfect for anyone seeking understated originality, design that's different with no excesses. In interior design, rounded forms are always elegant and suited to modern, sophisticated dining rooms.

Table Triade

Tavolo rettangolare fisso

Fixed rectangular table

IT Il piano in vetro, essenza, colori neutri, effetti marmo e cemento è sorretto da un originale basamento in metallo, disponibile in diverse tonalità. Tre lunghezze diverse per tutte le tipologie di spazio.

EN Glass or wooden top, neutral colours, marble and concrete effects, supported by an original metal base, available in different colour tones. Three different lengths for all types of spaces.

DIMENSIONI dimensions

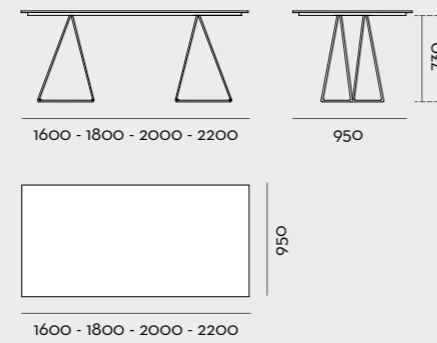

PIANO top

Melaminici Melamine



Melaminici Melamine

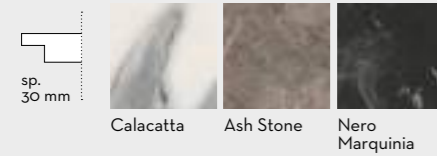

Vetro Glass

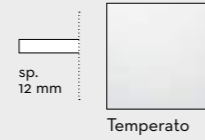

Rovere massiccio Solid oak



Frassino Olivato massiccio Solid Olive Ash

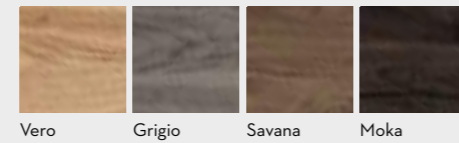

STRUTTURA frame

Laccati opachi in tutti i colori della mazzetta
Matt colour lacquered all the sample colours



Rovere / Oak
Thea

Laccato opaco / Matt Lacquered
Ottone

Tavolo Triade
L 2000 x L 950 x H 760 mm

→
Tavolo Triade
L 2000 x L 950 x H 742 mm

Vetro / Glass
Temperato

Laccato opaco / Matt Lacquered
Ottone





GAMBE IN METALLO

IT I sottili tondini in metallo disegnano una geometria a triangoli: semplice ma d'effetto per un tavolo moderno.

EN Slim metal rods create a geometry of triangles: simple yet eye-catching for a modern table.

Metal legs
↑

Table Run

Tavolo tondo

IT Il basamento in essenza o laccato è formato da tre gambe inclinate e unite sulla sommità per sostenere un piano in vetro trasparente. Con le sue dimensioni, il tavolo è perfetto per arredare un angolo conviviale.

EN The base can be wood or lacquered: three sloping legs merge to provide support for a transparent glass top. The dimensions of this table make it perfect for a convivial corner.

Round table ↑

DIMENSIONI dimensions

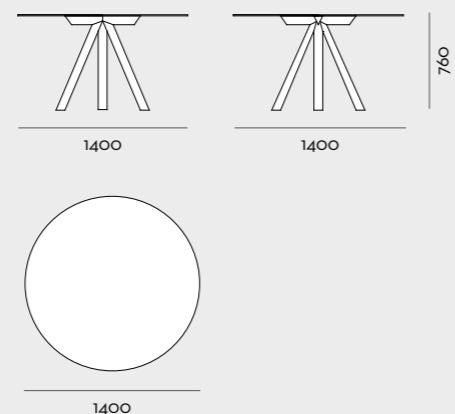

PIANO top

Vetro Glass

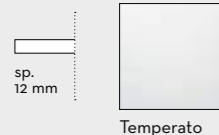

STRUTTURA frame

Frassino Ash

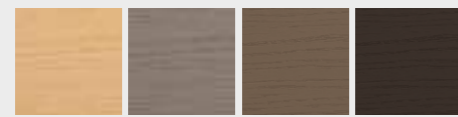

Vero Grigio Savana Moka

Frassino colore laccato in tutti i colori della mazzetta
Colour lacquered ash all the sample colours



Frassino colore / Colour ash
Bianco

Vetro / Glass
Temperato

Tavolo Run
Ø 1400 x H 760 mm



Tavolo Run
Ø 1400 x H 760 mm

Vetro / Glass
Temperato

Frassino colore / Colour ash
Bianco



PIANO IN VETRO

^{IT} La trasparenza del vetro mette in risalto il design del basamento, che diventa protagonista del tavolo e dello spazio.

^{EN} The transparent glass top shows off the charming design of the base of this table.

Glass top
↑



Table Gelius

Tavolo rettangolare fisso

Fixed rectangular table ↑

IT I gamboni in vetro trasparente sono alla base di un piano che può essere realizzato in vetro, essenza, colori neutri, effetti marmo e cemento, ma anche in diverse tonalità di rovere e frassino massiccio.

EN Transparent glass supports for a table top which can itself by glass, or wood, neutral colours, marble and concrete effects, but even different shades of oak and solid ash.

DIMENSIONI dimensions

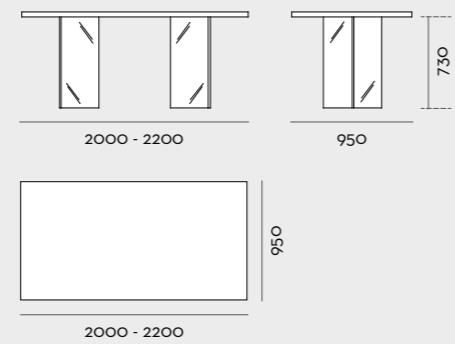

PIANO top

Melaminici Melamine

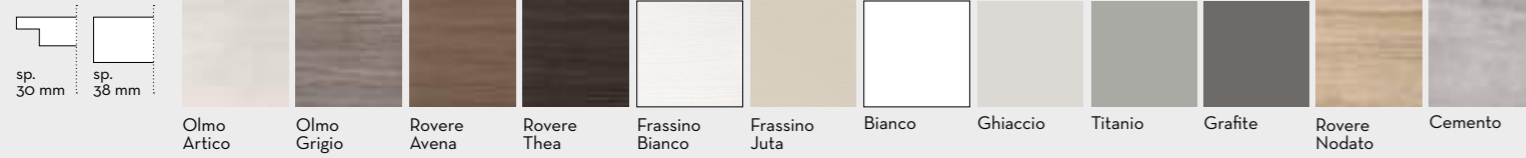

Melaminici Melamine

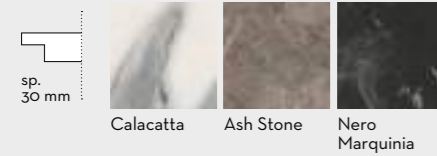

Rovere massiccio Solid oak



Frassino Olivato massiccio Solid Olive Ash

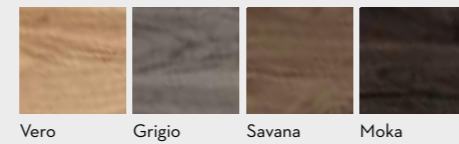

STRUTTURA frame

Vetro Glass



Vetro / Glass
Temperato

Melaminico Colore / Colour Melamine
Bianco

Tavolo Gelius
L 2000 x L 950 x H 760 mm



Tavolo Gelius
L 2200 x L 950 x H 760 mm

Rovere / Oak
Thea

Vetro / Glass
Temperato

Table **Cleo**



Tavolo Cleo
L 1800 x L 950 x H 765 mm

Rovere / Oak
Grigio

Vetro / Glass
Temperato

ALLUNGA "CON GUIDE"

^{IT} Il tavolo in legno massiccio si allunga grazie a due prolunghe esterne che si agganciano su uno o entrambi i lati.

^{EN} Solid wood table with extension panels that attach to both ends.

Side extensions
↑





LEGNO MASSICCIO

IT In sala da pranzo, il tavolo è protagonista con la sua presenza materica che unisce il legno massiccio al vetro.

EN This table is the focus of the dining room with its textured blend of solid wood and glass.

Solid wood ↑

DIMENSIONI dimensions

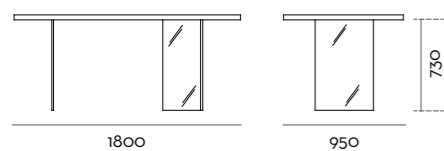

Tavolo Cleo
L 1800 x L 950 x H 765 mm

Rovere / Oak
Vero

Vetro / Glass
Temperato



Table Felix

Tavolo rettangolare allungabile

Extendable rectangular table ↑

IT La struttura in rovere con le gambe "a cavalletto" e il piano in vetro danno forma a un tavolo che si allunga notevolmente: un sistema di scorrimento inserito sotto il piano permette di estrarre le allunghe.

EN An oak frame, trestle legs and a glass top for this extendable table: a sliding system beneath the top allows the extensions to be removed.

DIMENSIONI dimensions

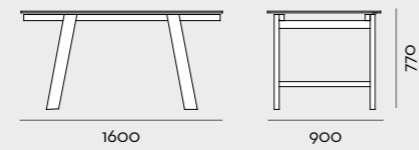

2 allunghe laterali 2 side extension panels

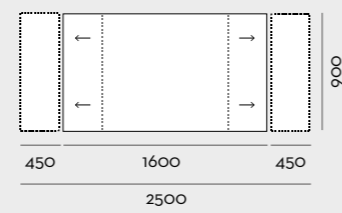

PIANO top

Vetro Glass

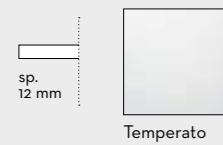

STRUTTURA frame

Rovere Oak

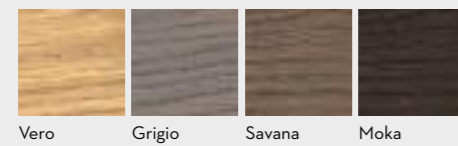

Rovere / Oak
Vero

Vetro / Glass
Temperato

Tavolo Felix
L 1600 x L 900 x H 770 mm



Tavolo Felix
L 2500 x L 900 x H 770 mm

Vetro / Glass
Temperato

Rovere / Oak
Vero



ALLUNGHE SCORREVOLI

^{IT} Le prolunghe del tavolo sono posizionate sotto il piano fisso e all'occorrenza possono essere estratte con facilità.

^{EN} The table extension panels are easy to remove when needed from below the top.

Sliding extension panels
↑

Table Poker

Tavolo rettangolare allungabile

Extendable rectangular table ↑

IT Il tavolo con basamento in metallo nero e piano in essenza, rovere, effetti marmo e cemento, è disponibile con due lunghezze fisse e si estende sia in lunghezza, sia in larghezza.

EN Table with black metal base and wood, oak, marble effect or concrete effect top, available in two fixed lengths and extension both lengthways and widthways.

DIMENSIONI dimensions

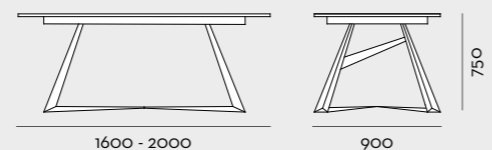

COMPONIBILITÀ modularity

Tavolo chiuso closed table

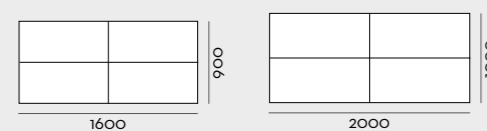

Tavolo 1 allunga table 1 extension panel

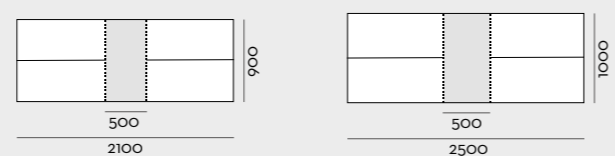

Tavolo 2 allunghe table 2 extension panels

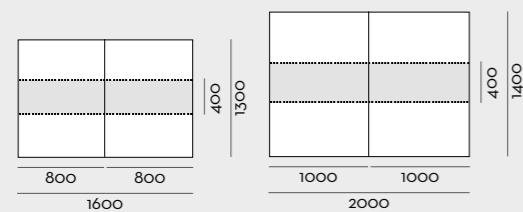

Tavolo 3 allunghe table 3 extension panels

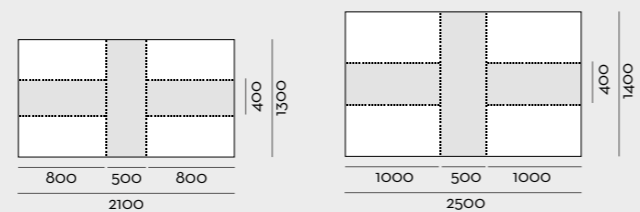

PIANO top

Melaminici Melamine

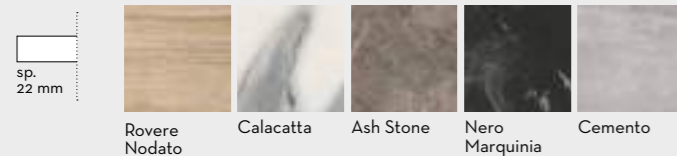

Rovere Oak

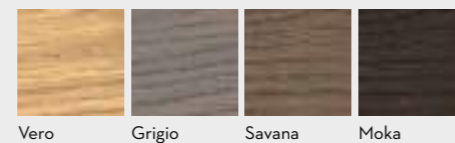

STRUTTURA frame

Metallo Metal

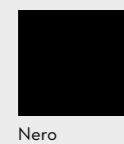

Metallo / Metal
Nero opaco

Rovere / Oak
Vero

Tavolo Poker
L. 1600 x L. 900 x H. 750 mm

BASAMENTO SCULTOREO

^{IT} Il basamento solido e dal volume importante è stato progettato per sostenere con sicurezza piani ampi.

^{EN} The solid, impressive base is designed to safely support large tops.

Sculpted base
↑





Tavolo Poker
L 1600 x L 900 x H 750 mm

Melaminico Marmo / Marble Melamine
Nero Marquinia

Metallo / Metal
Nero opaco





Tavolo Poker
L 2500 x L 1000 x H 750 mm

TAVOLO MODULARE

IT Un sistema di allunghe esterne in dotazione permette di configurare un tavolo più lungo e anche più largo.

EN An external extension system allows you to configure the table to become be wider and longer.

Modular table



Tavolo Poker
L 2000 x L 1400 x H 750 mm

Table **Fix**

Tavolo rettangolare allungabile

Extendable rectangular table ↑

IT Il basamento in metallo nero è l'elemento caratterizzante del tavolo. Il piano può essere realizzato in quattro tonalità di rovere, effetti marmo o cemento e si estende da un lato con due allunghe.

EN The black metal base is the distinguishing feature of this table. The top is available in four shades of oak, marble or concrete effects and can be extended on one side with two extension panels.

DIMENSIONI dimensions

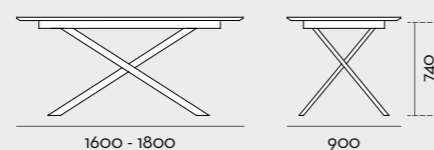

2 allunghe laterali 2 side extension panels



PIANO top

Rovere Oak

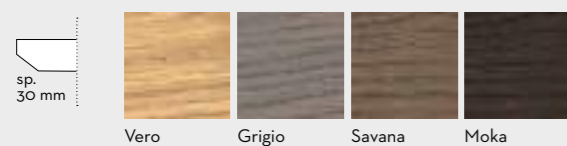

Melaminici Melamine

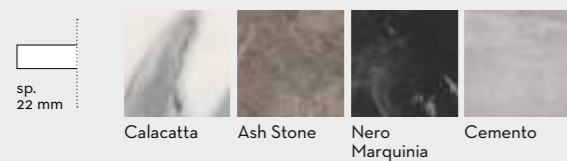

STRUTTURA frame

Metallo Metal

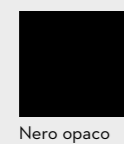

Metallo / Metal
Nero opaco

Rovere / Oak
Vero

Tavolo Fix
L 1800 x L 900 x H 770 mm



Tavolo Fix
L 1800 x L 900 x H 762 mm

Melaminico / Melamine
Cemento

Metallo / Metal
Nero opaco





LATO ALLUNGABILE

^{IT} All'occorrenza, le allunghe nascoste sotto il piano possono essere estratte per aumentare i posti a sedere attorno al tavolo.

^{EN} The extensions hidden beneath the table top can be pulled out when needed to provide extra seating space.

Extendable side ↑

Table Venus

Tavolo rettangolare allungabile

Extendable rectangular table

IT Il basamento del tavolo è caratterizzato da una doppia finitura: il metallo è abbinato allo stesso materiale del piano, ovvero rovere, effetti marmo o cemento. Le allunghe centrali aumentano le dimensioni.

EN The table base features two finishes: metal combined with the same material as the top which is available in oak, marble effect or concrete effect. The central extension panels increase the dimensions.

DIMENSIONI dimensions

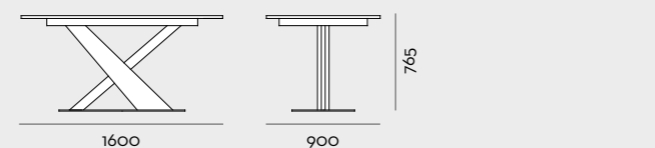

2 allunghe centrali 2 central extension panels

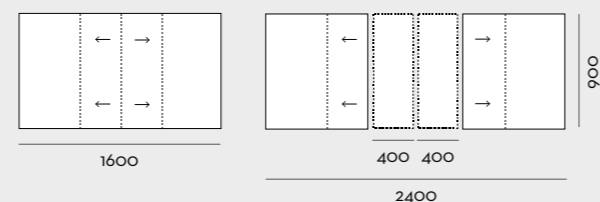

PIANO top



Rovere Oak

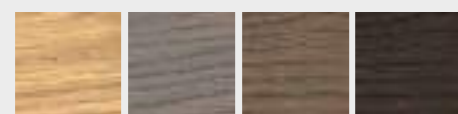

Vero Grigio Savana Moka

Melaminici Melamine

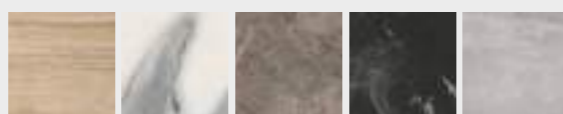

Rovere Nodato Calacatta Ash Stone Nero Marquinia Cemento

STRUTTURA frame

Metallo Metal

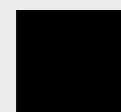

Nero opaco

+

Rovere Oak

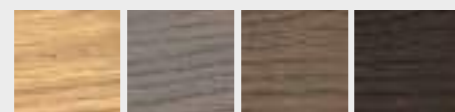

Vero Grigio Savana Moka

Metallo Metal

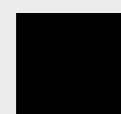

Nero opaco

+

Melaminici Melamine

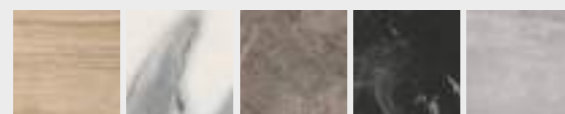

Rovere Nodato Calacatta Ash Stone Nero Marquinia Cemento



Metallo / Metal
Nero opaco

Rovere / Oak
Vero

Tavolo Venus
L 1600 x L 900 x H 765 mm



Tavolo Venus
L 2400 x L 900 x H 765 mm

Melaminico Marmo / Marble Melamine
Ash Stone

Metallo / Metal
Nero opaco

**BASAMENTO E PIANO COORDINATI**

^{IT} Il tavolo è un vero e proprio elemento d'arredo e si fa notare per l'abbinamento della finitura tra base e piano.

^{EN} This table is centrepiece for its setting, with matching finishes for the base and top.

Coordinated base and top ↑

Table Spring

Tavolo rettangolare fisso

Fixed rectangular table

IT Due gamboni in metallo sostengono un piano in rovere dal forte spessore, visivamente alleggerito da un inserto in resina che attraversa il tavolo in tutta la sua lunghezza. Disponibile in tre dimensioni.

EN Two large metal supports for a robust oak top, set off visually by a resin insert along the entire length of the table. Available in three sizes.

DIMENSIONI dimensions

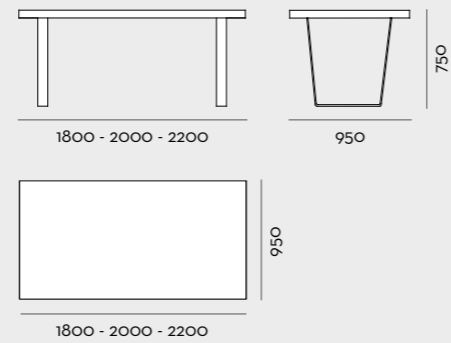

PIANO top

Rovere Oak



sp. 50 mm

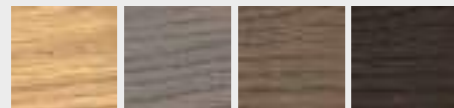

Vero Grigio Savana Moka

Resina Resin

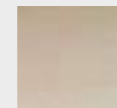

STRUTTURA frame

Metallo Metal

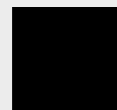

Nero opaco



Metallo / Metal
Nero opaco

Inserto in resina /
Resin insert

Rovere / Oak
Vero

Tavolo Spring
L 1800 x L 950 x H 750 mm

→
Tavolo Spring
L 2200 x L 950 x H 750 mm

Rovere / Oak
Vero

Inserto in Resina / Resin insert

Metallo / Metal
Nero opaco





INSERTO IN RESINA

IT La trasparenza della resina incontra la solidità del legno e insieme danno forma a un tavolo molto naturale.

EN The transparency of resin meets the solidity of wood to give shape to a stunning natural-looking table.

Resin insert
↑



Table Planet

Tavolo rettangolare fisso

Fixed rectangular table

IT Il basamento in metallo è formato da quattro gambe inclinate. Il piano è disponibile in tre lunghezze e realizzabile in vetro, essenza, colori neutri, effetti marmo e cemento, rovere e frassino massiccio.

EN The metal base consists of four sloping legs. The top is available in three lengths, in glass, wood, neutral colours, marble and concrete effects, solid oak and ash.

DIMENSIONI dimensions

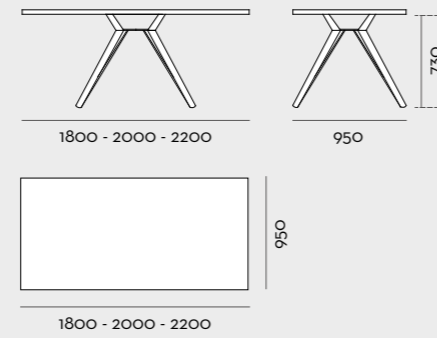

PIANO top

Melaminici Melamine

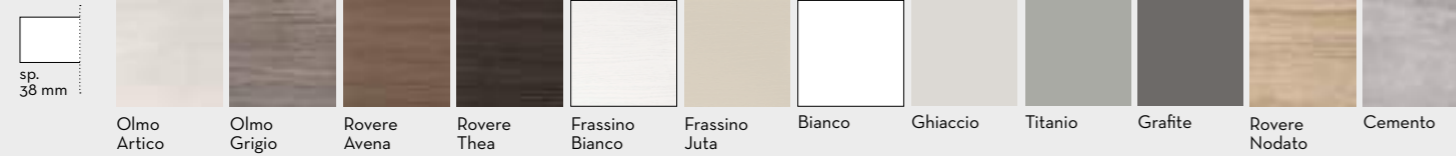

Vetro Glass

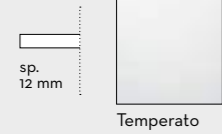

Rovere massiccio Solid Oak

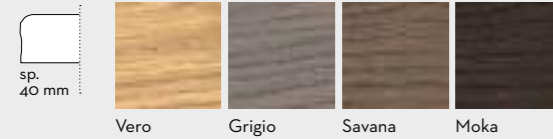

STRUTTURA frame

Metallo Metal

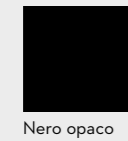

Tavolo Planet
L 1800 x L 950 x H 770 mm

Rovere / Oak
Vero

Metallo / Metal
Nero opaco



Tavolo Planet
L 2000 L 950 H 768 mm

Melaminico Colore / Colour Melamine
Bianco

Metallo / Metal
Nero opaco

Table Club

Tavolo rettangolare fisso

Fixed rectangular table ↑

IT Gli incroci delle gambe in metallo sostengono un piano disponibile in due lunghezze, che può essere realizzato in sei essenze, quattro colori neutri o quattro tonalità di rovere massiccio.

EN Crossed metal legs support a top available in two lengths, available in six woods, four neutral colours or four shades of solid oak.

DIMENSIONI dimensions

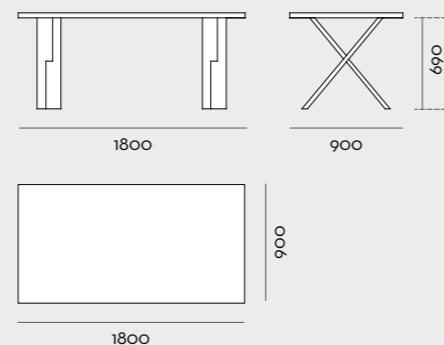

PIANO top

Melaminici Melamine



Rovere massiccio Solid Oak

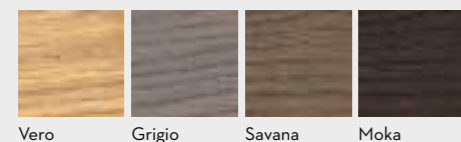

STRUTTURA frame

Metallo Metal



Nero opaco



Metallo / Metal
Nero opaco

Rovere / Oak
Vero

Tavolo Club
L 1800 x L 900 H 734 mm



GAMBE IN METALLO

IT Le gambe in metallo nero sono evidenti: il loro spessore e la forma a X rendono il tavolo adattabile a contesti moderni.

EN The thickness and X-shape of the striking black metal legs make this table suitable for modern settings.

Metal legs ↑



Tavolo Club
L 1800 L 900 H 730 mm

Rovere / Oak
Vero

Metallo / Metal
Nero opaco



Table Drop

Tavolo rettangolare fisso

Fixed rectangular table

IT Il tavolo in rovere impiallacciato è disponibile in quattro tonalità. Le due gambe in metallo dalla forma geometrica sostengono il piano e allo stesso tempo si inseriscono con originalità nella superficie.

EN Veneered oak table available in four shades. The two geometrical metal legs are original and provide support to the table top.

DIMENSIONI dimensions

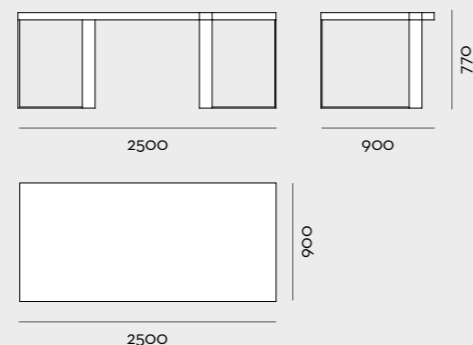

PIANO top

Rovere Oak

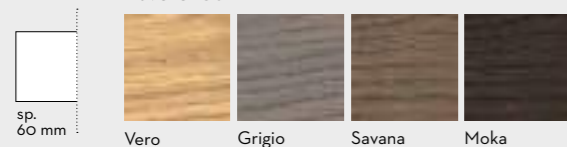

STRUTTURA frame

Metallo Metal

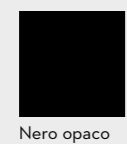

Metallo / Metal
Nero opaco

Rovere / Oak
Vero

Tavolo Drop
L 2500 x L 900 x H 770 mm



Tavolo Drop
L 2500 x L 900 x H 770 mm

Rovere / Oak
Vero

Metallo / Metal
Nero opaco

→

IT Le gambe del tavolo proseguono verso l'alto fino alla parte superiore del piano: gli inserti in metallo sono visibili sulla superficie e caratterizzano l'arredo nel suo insieme. Una soluzione che abbina legno e metallo in modo originale, per un'autenticità che sa distinguersi.

EN The table legs extend to the top of the table: the metal inserts are visible on the surface and are a feature of the entire piece. A solution that combines wood and metal for distinctive authenticity.



↑ **Rovere / Oak**
Vero

Table Taiga

Tavolo rettangolare fisso

Fixed rectangular table

IT Le tre lunghezze del tavolo possono essere realizzate in essenza, colori neutri, effetti marmo e cemento, rovere e frassino massiccio. Le gambe in metallo sono unite da un elemento centrale.

EN The table is available in three lengths, in wood, neutral colours, marble and concrete effects, solid oak and ash. The metal legs are joined via a central element.

DIMENSIONI dimensions

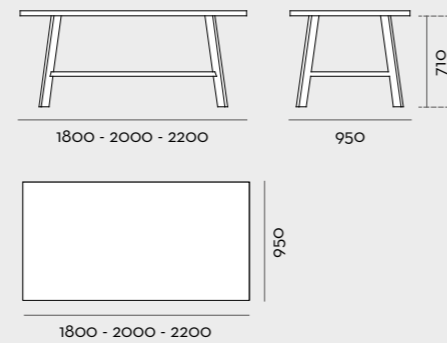

PIANO top

Melaminici Melamine



Melaminici Melamine

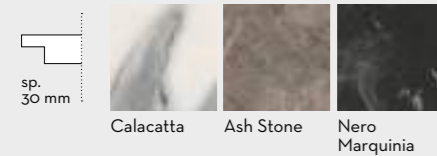

Rovere massiccio Solid Oak



Frassino Olivato massiccio Solid Olive Ash

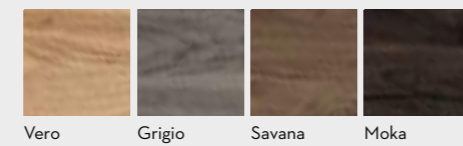

STRUTTURA frame

Metallo Metal

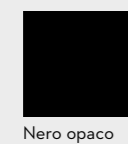

Metallo / Metal
Nero opaco

Rovere / Oak
Vero

Tavolo Taiga
L 1800 x L 950 x H 745 mm

→
Tavolo Taiga
L 2200 x L 950 x H 740 mm

Melaminico / Melamine
Cemento

Metallo / Metal
Nero opaco





Tavolo Taiga
L 2000 x L 950 x H 745 mm

Frassino Olivato massiccio / Solid Olive Ash
Vero

Metallo / Metal
Nero opaco





FRASSINO OLIVATO

^{IT} I nodi evidenti e le venature marcate esprimono l'autenticità del legno e rendono il tavolo unico e inimitabile.

^{EN} The visible knots and marked veins show the authenticity of the wood and make this table unique and inimitable.

Olive ash ↑



Tavolo Taiga
L 2000 x L 950 x H 745 mm

Melaminico Rovere / Oak Melamine
Avena

Metallo / Metal
Nero opaco

Table Strong

Tavolo rettangolare fisso

Fixed rectangular table ↑

IT Il tavolo è realizzabile in essenza, colori neutri, effetti marmo e cemento, rovere e frassino massiccio ed è disponibile in tre diverse lunghezze. Due staffe in metallo sostengono il piano e caratterizzano il design.

EN The table is available in three lengths, in wood, neutral colours, marble and concrete effects, solid oak and ash. Two metal brackets support the top as well as being design features.

DIMENSIONI dimensions

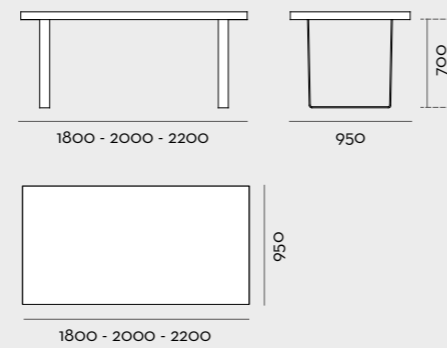

PIANO top

Melaminici Melamine



Melaminici Melamine

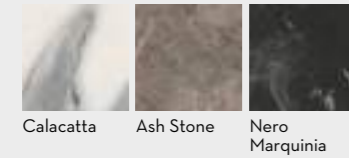

Rovere massiccio Solid Oak



Frassino massiccio Solid Ash

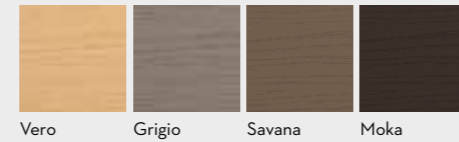

STRUTTURA frame

Metallo Metal

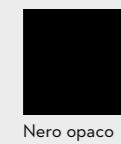

Metallo / Metal
Nero opaco

Rovere / Oak
Vero

Tavolo Strong
L 1800 x L 950 H 744 mm

Table **Dafne**

Tavolo rettangolare allungabile

Extendable rectangular table

IT La struttura in metallo bianco o nero si abbina alle molteplici finiture del piano: in vetro, essenza, colori neutri, cemento, rovere e colori laccati. La convivialità si personalizza e si estende.

EN The black and white metal frame accompanies any of the finishes available for the top: glass, wood, neutral colours, cement effect, oak or lacquered colours. Personalisation and extension of conviviality.

DIMENSIONI dimensions

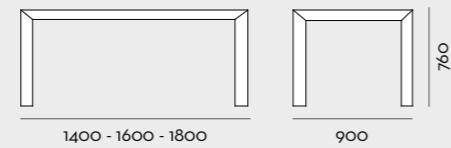

1 allunga laterale 1 side extension panel

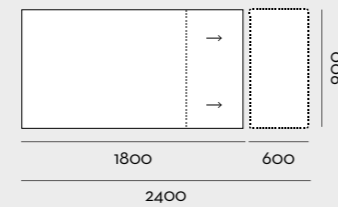

PIANO top

Melaminici Melamine

sp.
22 mm



Rovere Oak

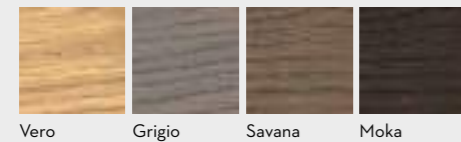

Laccati opachi in tutti i colori della mazzetta
Matt colour lacquered all the sample colours

Frassino colore laccato in tutti i colori della mazzetta
Colour lacquered ash all the sample colours

Vetro - solo per tavolo allungabile Glass - only for extendable tables

sp.
6 mm

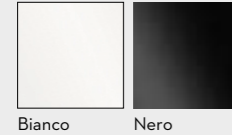

STRUTTURA frame

Metallo Metal



Metallo / Metal
Bianco opaco

Vetro / Glass
Bianco

Tavolo Dafne
L 1800 x L 900 x H 760 mm



Tavolo Dafne
L 2400 x L 900 x H 760 mm

Vero / Glass
Bianco

Metallo / Metal
Bianco opaco



GAMBE PERIMETRALI

^{IT} Il tavolo si estende grazie ad un meccanismo che, oltre ad allungare il piano, fa scorrere di lato anche le gambe.

^{EN} A special mechanism not only extends the table top and but also slides the legs outwards.

Perimeter legs
↑



→

Il piano in vetro bianco alleggerisce i tavoli dalle dimensioni più importanti: lo spessore è molto sottile e la brillantezza della superficie rende luminoso l'arredo e anche la stanza che lo contiene. Si consigliano sedie a contrasto per creare uno spazio conviviale dal grande stile.

The white glass top offsets the large dimensions of these tables: slim lines and glossy surfaces add light to the piece and its setting. Choose contrasting chairs to bring style to a convivial atmosphere.



↑ Vetro sp. 6 mm / Glass th. 6 mm
Bianco



→
Tavolo Dafne
 L 2400 x L 900 x H 760 mm

Melaminico / Melamine
 Cemento

Metallo / Metal
 Nero opaco



↑ **Melaminico / Melamine**
Cemento



IT L'effetto cemento è tra le finiture di tendenza per rivestire arredi moderni. Il tavolo ha un look materico, un design lineare e un carattere deciso che gli permettono di inserirsi in case moderne, ma anche in spazi di lavoro, che cercano di proporre uno stile nuovo e molto attuale.

EN Concrete effect is the on-trend finish for modern atmospheres. The textured look, linear design and bold character of the table make it ideal for modern homes, but also work settings with a new, current style.

Table **Royal**

Tavolo rettangolare allungabile

Extendable rectangular table ↑

IT Le gambe sono unite alla struttura in metallo nero che può essere abbinata a un piano in rovere, essenza, effetti marmo e cemento, colori laccati. Due allunghe laterali aumentano la superficie utile.

EN The legs are joined to the black metal frame which can be combined with an oak, wood, marble effect, cement effect or lacquered colour top. Two side extension panels increase the available space.

DIMENSIONI dimensions

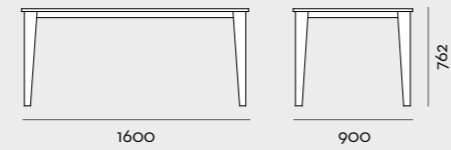

2 allunghe laterali 2 side extension panels

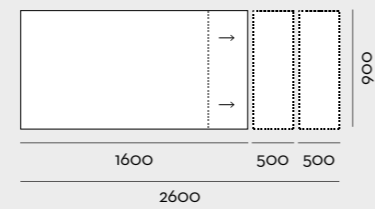

PIANO top

Melaminici Melamine

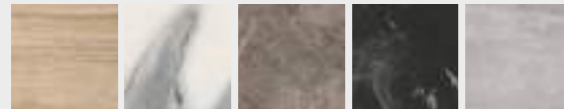

Rovere Nodato Calacatta Ash Stone Nero Marquina Cemento

Laccati opachi in tutti i colori della mazzetta
Matt colour lacquered all the sample colours

STRUTTURA frame

Metallo Metal



Nero opaco



Metallo / Metal
Nero opaco

Melaminico / Melamine
Cemento

Tavolo Royal
L 1600 x L 900 x H 762 mm



Tavolo Royal
L 2600 x L 900 x H 762 mm

Melaminico / Melamine
Cemento

Metallo / Metal
Nero opaco



GAMBE ALLINEATE AL PIANO

IT Le gambe perimetrali si spostano lateralmente quando il piano viene allungato e rimangono in linea con il piano.

EN The perimeter legs move outwards to stay aligned with the top when it is extended.

Legs aligned with the top ↑



Table Prisma

Tavolo rettangolare allungabile

Extendable rectangular table

IT La struttura in frassino racchiude un piano in essenza disponibile in quattro tonalità più un particolare effetto vintage. L'effetto può essere monocromatico oppure si possono creare abbinamenti diversi.

EN The ash frame frames a wood top available in four shades and a vintage effect finish. The effect can be monochromatic or various combinations.

DIMENSIONI dimensions

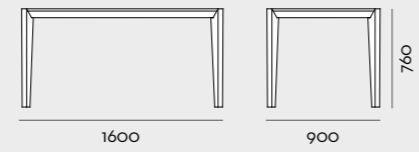

2 allunghe laterali 2 side extension panels

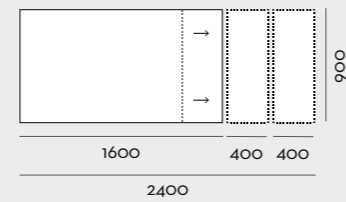

PIANO top

Frassino impiallacciato Veneered ash

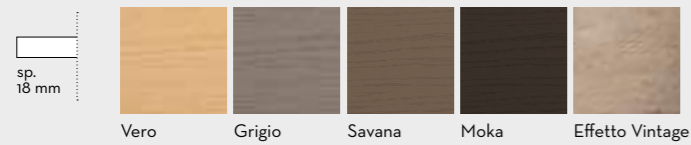

STRUTTURA frame

Frassino Ash

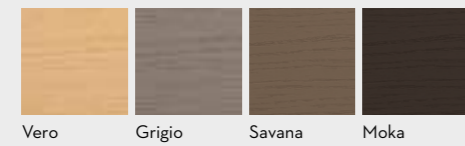

Frassino / Ash Vero

Tavolo Prisma L. 1600 x L. 900 x H. 760 mm

ALLUNGHE NASCOSTE

^{IT} Le due allunghe sono inserite nella struttura del tavolo e si estraggono facilmente solo quando servono.

^{EN} The two extension panels are part of the frame of the table and are easy to access when needed.

Hidden extension panels
↑





STRUTTURA IN FRASSINO

^{IT} La struttura del tavolo è visibile anche dall'alto, ai lati del piano, dove è visibile l'intaglio delle gambe.

^{EN} The frame of the table is also visible from above, at the sides of the top, where the shaping of the legs is visible.

Ash frame ↑



Tavolo Prisma
L 2400 x L 900 x H 760 mm

Frassino / Ash
Vero - Effetto Vintage



Table Mikado

Tavolo rettangolare allungabile

Extendable rectangular table

IT Le gambe in frassino sono disponibili in quattro tonalità naturali e delimitano un piano realizzabile in diversi colori laccati. Il tavolo è essenziale nella forma, ma offre tante possibilità di personalizzazione.

EN The ash legs are available in four natural colour temperatures and frame a top in one of several lacquered colours. The table is minimal in shape, but provides many customisation options.

DIMENSIONI dimensions

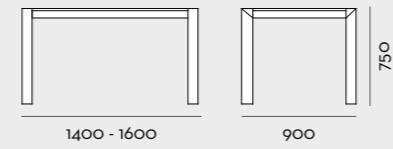

2 allunghe laterali 2 side extension panels

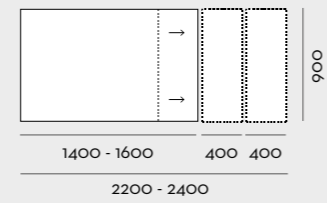

PIANO top



Laccati opachi in tutti i colori della mazzetta
Matt colour lacquered all the sample colours

STRUTTURA frame

Frassino Ash

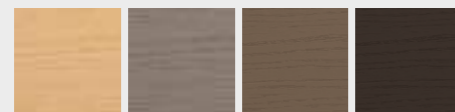

Vero Grigio Savana Moka



Frassino / Ash
Vero

Laccato opaco / Matt Lacquered
Verde Palude

Tavolo Mikado
L 1400 x L 900 x H 750 mm



Tavolo Mikado
L 2200 x L 900 x 750 mm

Frassino / Ash
Vero

Laccato opaco / Matt Lacqured
Bianco





DOPPIA FINITURA

IT La struttura non è nascosta, ma è visibile ai lati del tavolo: la doppia finitura crea un effetto bicolore sul piano.

EN The frame is not concealed, and can be seen on the sides of the table. The double finish creates a two-tone effect on the top.

Double finish
↑



Tavolo Mikado
L 1400 x L 900 x H 750 mm



Table Icaro

Tavolo apertura a libro

IT Il piano del tavolo quadrato si apre e raddoppia la sua lunghezza. Una pratica soluzione salvaspazio che permette di aumentare la superficie con un semplice movimento. Tante le finiture disponibili.

EN The top of this square table opens up to double the length. A practical space-saving solution that increases the available surface in one simple movement. Several finishes available.

Folding table ↑



DIMENSIONI dimensions

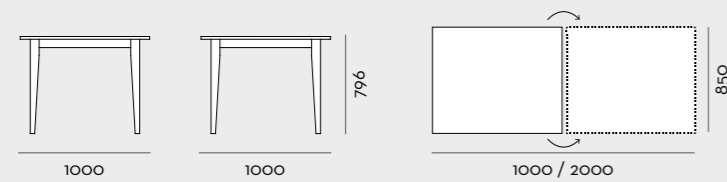

PIANO top

Melaminici Melamine

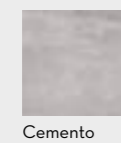

Laccati opachi in tutti i colori della mazzetta
Matt colour lacquered all the sample colours

Frassino colore laccato in tutti i colori della mazzetta
Colour lacquered ash all the sample colours

STRUTTURA frame

Laccati opachi in tutti i colori della mazzetta
Matt colour lacquered all the sample colours

Frassino colore laccato in tutti i colori della mazzetta
Colour lacquered ash all the sample colours



Melaminico Frassino / Ash Melamine
Bianco

Tavolo Icaro
L 1000 x L 1000 x H 796 mm

Table Icaro

Tavolo rettangolare allungabile

Extendable rectangular table

IT La struttura in laccato colorato o frassino laccato può essere abbinata al piano nella stessa finitura oppure in essenza, colori naturali, effetti marmo e cemento. Un'allunga estende le misure.

EN The frame in coloured lacquered or lacquered ash can be combined with a top in the same finish or in wood, natural colours, marble effect or cement effect. An extension panel increases the available dimensions.



DIMENSIONI dimensions

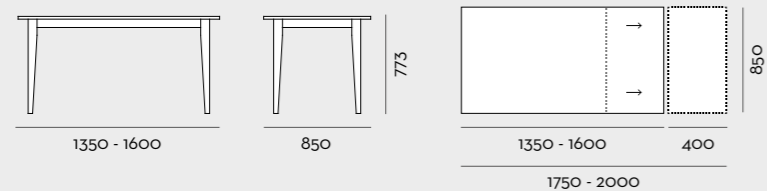

PIANO top

Melaminici Melamine

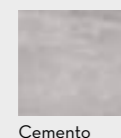
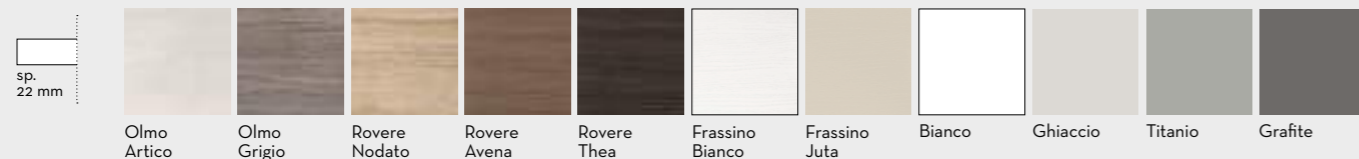

Laccati opachi in tutti i colori della mazzetta
Matt colour lacquered all the sample colours

Frassino colore laccato in tutti i colori della mazzetta
Colour lacquered ash all the sample colours

STRUTTURA frame

Laccati opachi in tutti i colori della mazzetta
Matt colour lacquered all the sample colours

Frassino colore laccato in tutti i colori della mazzetta
Colour lacquered ash all the sample colours



Chairs ↓

ATTORNO
AD UN
TAVOLO
ACCOLGONO
GLI OSPITI
E LO STILE.

Around a table they gather guests and style.

Sedie

Lineari o avvolgenti, le sedie esprimono tante forme di comodità. Linear or with cocoon effect, chairs offer numerous modes of comfort.

index

- 257 → Karol
- 259 → Opera
- 263 → Vanity
- 265 → Gaia
- 267 → Kelly
- 271 → Logan
- 273 → Diva
- 275 → Paola
- 277 → Giulia
- 279 → Dakota
- 283 → Ester
- 287 → Ariel
- 289 → Clelia

Chair **Karol**

Sedia con seduta imbottita

Chair with upholstered seat ↑

IT Un design essenziale ma avvolgente: lo schienale imbottito ha i lati leggermente ripiegati verso l'interno e massimizza la comodità della seduta imbottita. La sedia è bella da vedere, anche di profilo.

EN Essential but inviting. The sides of the upholstered backrest curve slightly inwards and the seat provides maximum comfort. Stunning even from the side view.

DIMENSIONI dimensions

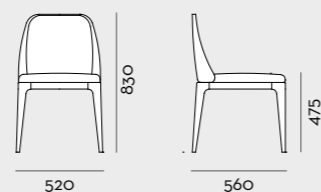

KAROL chair
SL153



SEDUTA - SCHIENALE seat - backrest

Tessuti - Ecopelli - Ecopelli Gold
Fabrics - Eco-leathers - Gold eco-leathers

STRUTTURA frame

Frassino massiccio Solid Ash

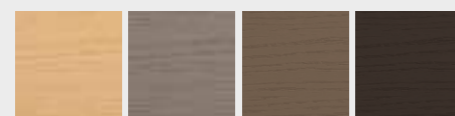

Vero Grigio Savana Moka

Struttura Frassino / Ash frame
Savana

Seduta - Schienale / Seat - Backrest
Tessuto / Fabric Rally 602

Sedia Karol

Chair Opera

Sedia con seduta imbottita

Chair with upholstered seat

IT Seduta e schienale sono un pezzo unico: la forma ergonomica e confortevole è accolta da una struttura in frassino massiccio, disponibile in quattro tonalità per abbinarsi a diversi tavoli.

EN The seat and backrest form a single unit. The comfortable ergonomics of this chair are provided by a solid ash frame available in four colour tones that can be matched to a variety of tables.

DIMENSIONI dimensions

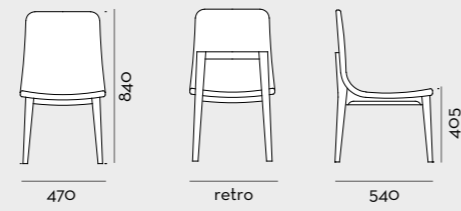

SEDUTA - SCHIENALE seat - backrest

Tessuti - Ecopelli - Ecopelli Gold
Fabrics - Eco-leathers - Gold eco-leathers

STRUTTURA frame

Frassino massiccio Solid Ash

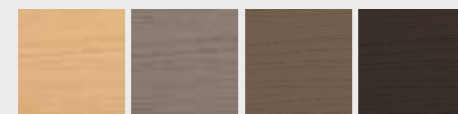

Vero Grigio Savana Moka



OPERA chair
SL155



Struttura Frassino / Ash frame
Moka

Seduta - Schienale / Seat - Backrest
Tessuto / Fabric Rally 405

Sedia Opera

Chair **Opera**



Chair **Vanity**

Sedia con seduta imbottita

Chair with upholstered seat ↑

IT La struttura, esile nella forma e robusta nella sostanza, sostiene la seduta imbottita che diventa un tutt'uno con lo schienale. Il frassino massiccio è abbinato a tessuti o ecopelli.

EN A slight frame with a robust personality supports an upholstered seat that forms a single unit with the backrest. Solid ash is combined with fabrics and faux leather.

DIMENSIONI dimensions

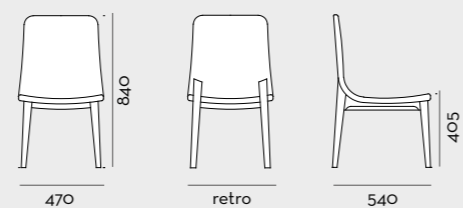

VANITY chair
SL156



SEDUTA - SCHIENALE seat - backrest

Tessuti - Ecopelli - Ecopelli Gold
Fabrics - Eco-leathers - Gold eco-leathers

STRUTTURA frame

Frassino massiccio Solid Ash

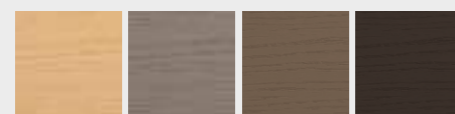

Vero Grigio Savana Moka

Struttura Frassino / Ash frame
Grigio

Seduta - Schienale / Seat - Backrest
Tessuto / Fabric Point 06

Sedia Vanity

Chair **Gaia**

Sedia con seduta imbottita

Chair with upholstered seat
↑

IT Una sedia elegante nello stile e comoda nella forma. Lo schienale con gli angoli arrotondati e leggermente ricurvo all'indietro è ergonomico, ma allo stesso tempo è una nota di design.

EN A chair that is elegant in style and comfortable in form. The backrest with rounded corners and curved slightly backwards is ergonomic yet stylish.

DIMENSIONI dimensions

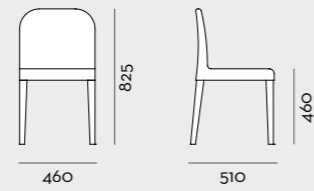

GAIA chair
SL119



SEDUTA - SCHIENALE seat - backrest

Tessuti - Ecopelli - Ecopelli Gold
Fabrics - Eco-leathers - Gold eco-leathers

STRUTTURA frame

Frassino massiccio Solid Ash

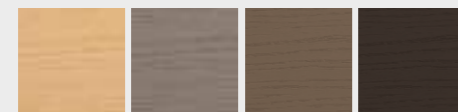

Vero Grigio Savana Moka

Laccati opachi in tutti i colori della mazzetta
Matt colour lacquered all the sample colours



Struttura Frassino / Ash frame
Savana

Seduta - Schienale / Seat - Backrest
Tessuto / Fabric Rally 602

Sedia Gaia

Chair Kelly

Sedia con seduta imbottita

Chair with upholstered seat ↑

IT In entrambe le versioni, con o senza bracciolo, la sedia esprime tutta la sua comodità e il suo stile. Il bordino a contrasto delinea i profili dello schienale e aggiunge un dettaglio sartoriale.

EN Both versions, with or without armrests, express all of their comfort and style. The contrasting trim outlines the backrest and adds a detail of tailoring.

DIMENSIONI dimensions

Kelly

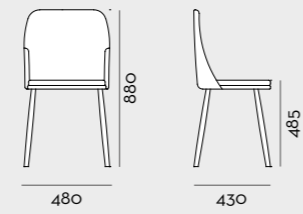

Kelly capotavola chair with armrests

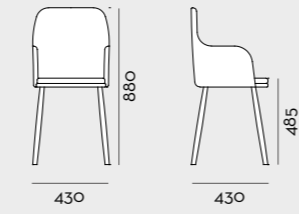

SEDUTA - SCHIENALE seat - backrest

Tessuti - Ecopelli - Ecopelli Gold
Fabrics - Eco-leathers - Gold eco-leathers

STRUTTURA frame

Metallo Metal

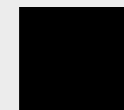

Nero opaco

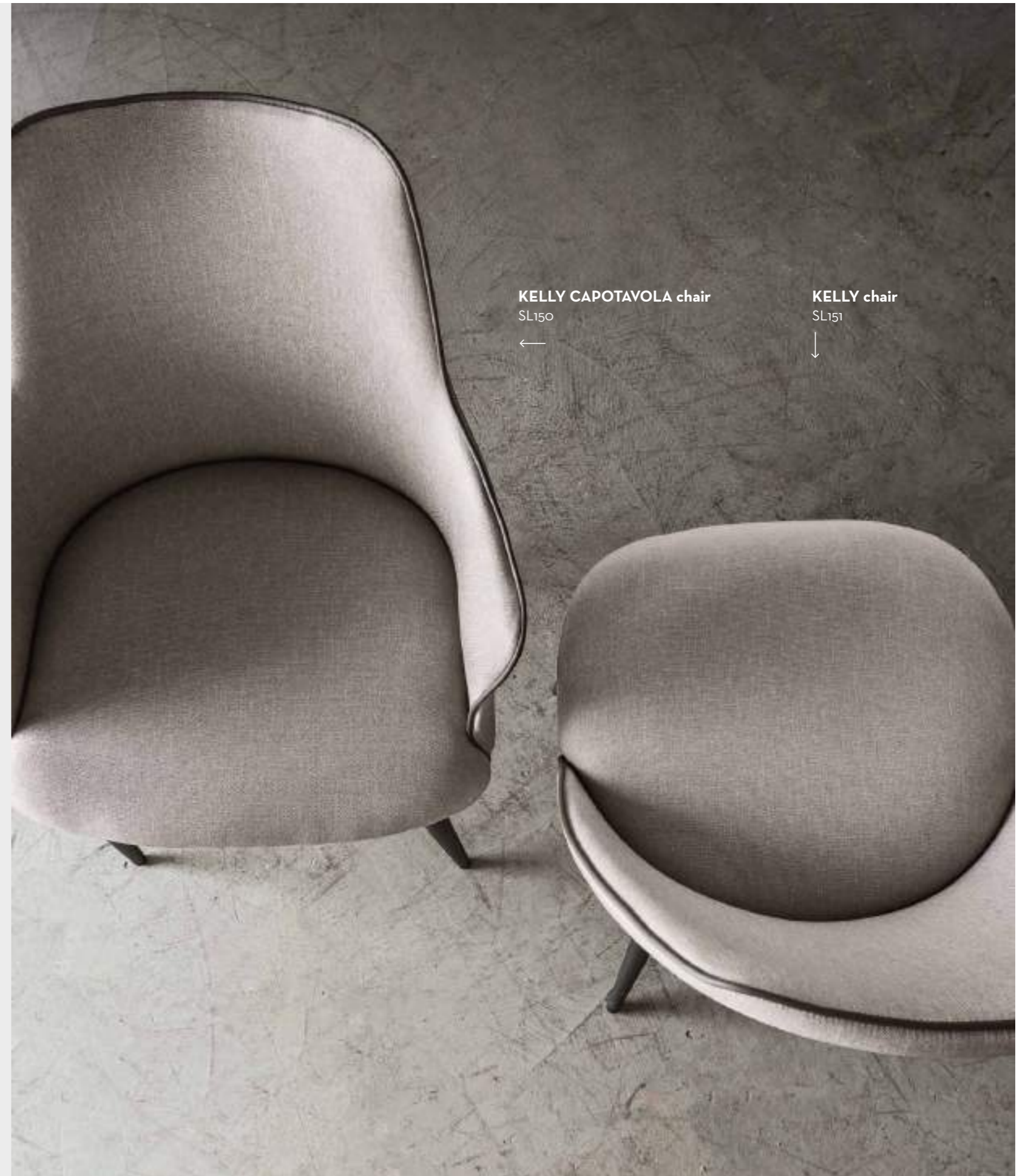

KELLY CAPOTAVOLA chair
SL150 ←

KELLY chair
SL151 ↓

Chair **Kelly**

KELLY CAPOTAVOLA chair
SL150



KELLY chair
SL151



Chair Logan

Sedia imbottita

Upholstered chair ↑

IT La sedia con braccioli ha un design che racchiude tutta la sua comodità: la forma ricurva della seduta e l'apertura sullo schienale sono i tratti distintivi che la rendono originale.

EN The design of the chair with armrests encapsulates the comfort it offers. The curved shape of the seat and the opening in the backrest are the distinctive features that make it an original piece.

DIMENSIONI dimensions

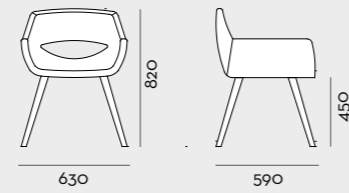

SEDUTA - SCHIENALE seat - backrest

Tessuti - Ecopelli - Ecopelli Gold
Fabrics - Eco-leathers - Gold eco-leathers

STRUTTURA frame

Frassino massiccio Solid Ash

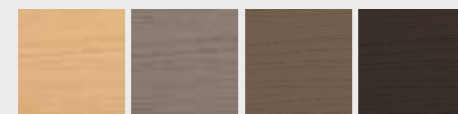

Vero Grigio Savana Moka



LOGAN chair
SL115



Struttura Frassino / Ash frame
Moka

Seduta - Schienale / Seat - Backrest
Tessuto / Fabric Rally 602

Sedia Logan

Chair **Diva**

Sedia con seduta imbottita

Chair with upholstered seat ↑

IT Il design elegante della seduta è sostenuto da un piedistallo, seduta e schienale sono un pezzo unico, l'apertura sul retro è un tocco di stile: la sedia attira su di sé l'attenzione, come una vera diva.

EN The elegant design of the seat is supported by a pedestal. The seat and backrest form a single unit and the opening in the rear adds a touch of style. Like a true diva, this chair captures your attention.

DIMENSIONI dimensions

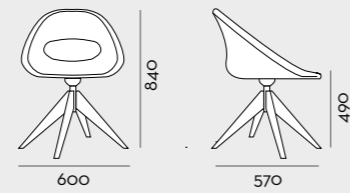

SEDUTA - SCHIENALE seat - backrest

Tessuti - Ecopelli - Ecopelli Gold
Fabrics - Eco-leathers - Gold eco-leathers

STRUTTURA frame

Frassino massiccio Solid Ash

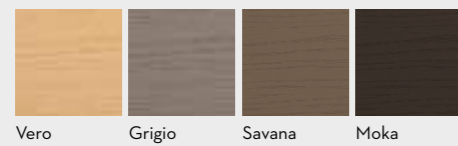

DIVA chair
SL157
↓

Struttura Frassino / Ash frame
Moka

Seduta - Schienale / Seat - Backrest
Tessuto / Fabric Rally 403

Sedia Diva

Chair Paola

Sedia con seduta imbottita

Chair with upholstered seat ↑

IT La sedia è interamente rivestita in cuoio rigenerato, disponibile in quattro tonalità. Due altezze di schienale corrispondono a due diverse idee di stile e comodità: basso e pratico, alto ed elegante.

EN The seat is covered entirely in regenerated leather, available in four colour tones. The two heights of the backrest equate to two different ideas of style and comfort: low and practical, high and elegant.

DIMENSIONI dimensions

Schienale basso low backrest

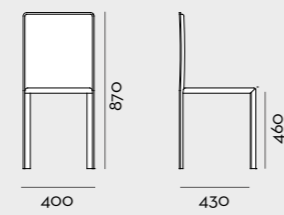

Schienale alto high backrest

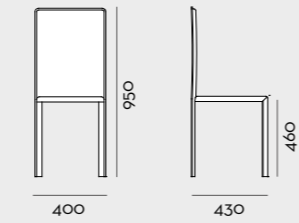

SEDUTA - SCHIENALE seat - backrest

Cuoio rigenerato Regenerated leather



Bianco Grigio Grafite Testa di Moro Nero

STRUTTURA frame

Metallo rivestito Upholstered metal



PAOLA schienale alto chair

SL117



PAOLA schienale basso chair

SL118



Chair **Giulia**

Sedia con seduta imbottita

Chair with upholstered seat

IT Tre rivestimenti per seduta e schienale, tre finiture per le gambe in metallo e due altezze di schienale per una sedia che si adatta a tutti gli spazi e a tutte le situazioni. Snella e pratica in entrambe le versioni.

EN Three coverings for seat and backrest, three finishes for metal legs and two backrest heights for a chair that adapts to any space and all situations. Both versions are slender and practical.

DIMENSIONI dimensions

Schienale basso low backrest

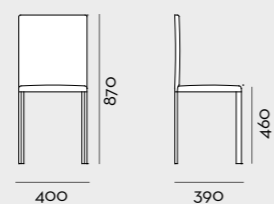

Schienale alto high backrest

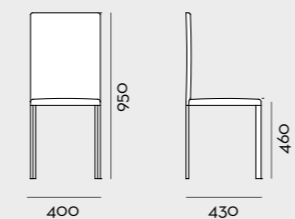

SEDUTA - SCHIENALE seat - backrest

Ecopelli Eco-leathers



Bianco Grigio Grafite Nero

STRUTTURA frame

Metallo Metal



Bianco Grigio Grafite Nero



GIULIA schienale basso chair

SL116



GIULIA schienale alto chair

SL120



Struttura Metallo / Metal frame
Nero opaco

Seduta - Schienale / Seat - Backrest
Ecopelle / Eco-leather Nero

Sedia Giulia

Chair **Dakota**

Sedia con seduta imbottita

Chair with upholstered seat ↑

IT Le gambe anteriori dritte e le gambe posteriori inclinate: un dettaglio che contribuisce a dare movimento al design e uno stile originale alla sedia. I diversi rivestimenti si abbinano alla struttura in frassino massiccio.

EN Straight front legs and sloping rear legs: a detail that adds movement to the design and an original style to the chair. Several coverings available to accompany the solid ash frame.

DIMENSIONI dimensions

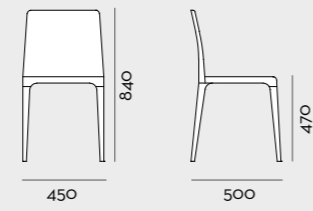

DAKOTA chair

SL152



SEDUTA - SCHIENALE seat - backrest

Tessuti - Ecopelli - Ecopelli Gold

Fabrics - Eco-leathers - Gold eco-leathers

STRUTTURA frame

Frassino massiccio Solid Ash

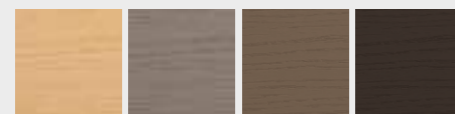

Vero Grigio Savana Moka

Struttura Frassino / Ash frame
Grigio

Seduta - Schienale / Seat - Backrest
Ecopelle / Eco-leather Tortora

Sedia Dakota

Chair **Dakota**



Chair **Ester**

Sedia con seduta imbottita

Chair with upholstered seat
↑

IT Una struttura in legno laccato, tanti colori disponibili, una seduta imbottita e linee svasate sono le caratteristiche di una sedia giovane e dinamica, che trova il suo spazio negli ambienti informali.

EN A lacquered wooden frame, several colours, an upholstered seat and flared lines are the characteristics of a young, dynamic chair that makes its mark in informal settings.

DIMENSIONI dimensions

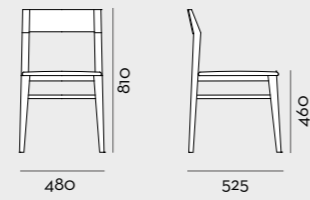

SEDUTA seat

Tessuti - Ecopelli - Ecopelli Gold
Fabrics - Eco-leathers - Gold eco-leathers

STRUTTURA frame

Frassino colore laccato in tutti i colori della mazzetta
Colour lacquered ash all the sample colours

ESTER chair

SL154



Struttura Frassino / Ash frame
Rosa Vintage

Seduta / Seat
Ecopelle / Eco-leather Grigio Perla

Sedia Ester

Chair **Ester**



Chair **Ariel****Sedia con struttura in policarbonato**Chair with
polycarbonate
frame ↑

IT Una sedia leggera e trasparente, che quasi non si fa notare ma dà stile a qualsiasi spazio con la sua presenza discreta. Perfetta negli ambienti moderni, molto originale in quelli più classici.

EN A light and transparent chair that almost passes unobserved, yet discreetly brings style to any space. Perfect in modern settings, original in more classic ones.

DIMENSIONI dimensions

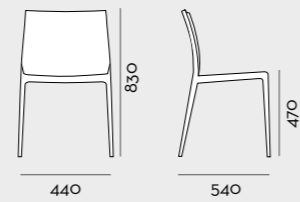

STRUTTURA frame

Policarbonato trasparente
Trasparente Polycarbonate

ARIEL chair
SL158

Struttura Policarbonato / Polycarbonate frame
Trasparente

Sedia Ariel

Chair Clelia

Sedia con struttura in polipropilene

Chair with polypropylene frame

IT Disponibile bianca o nera, la sedia monoblocco è leggera da spostare e pratica da utilizzare: può essere impilata e riposta quando non serve, per questo è un comodo complemento salvaspazio.

EN Available in black or white, this monobloc chair is lightweight and easy to use. It can be stacked and put away when not in use.

DIMENSIONI dimensions

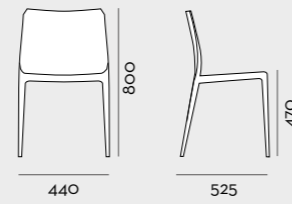

CELIA chair

SL133



STRUTTURA frame

Polipropilene Polypropylene

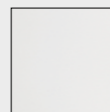

Bianco

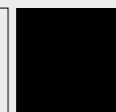

Nero



Struttura Polipropilene / Polypropylene frame
Laccato / Lacquered Bianco - Nero

Sedia Clelia

Armchairs / Poufs



ARREDANO
LO SPAZIO
E CREANO
VERI
ANGOLI DI
COMODITÀ.

Style and comfort for seated nooks.

Poltroncine Pouf

Forme morbide e confortevoli
per godersi un momento di relax.
Soft forms provide comfort
and relaxation.

index

295	→	Diana
297	→	Met
299	→	Nizza
301	→	Zalea
303	→	Guest
305	→	Asia
307	→	Pouf / Cusicni pouf / cushions



FORME DI COMODITÀ

^{IT} Le poltroncine interpretano la comodità in tanti modi diversi, grazie al loro design e ai molteplici rivestimenti disponibili.

^{EN} Design and a selection of coverings for armchairs that offer numerous shades of comfort.

The shape of comfort ↑

Armchair **Diana**

Poltroncina seduta H 430 mm

Armchair seat H 430 mm
↑

IT La seduta alta e lo schienale ricurvo trasmettono la sensazione di un grande comfort. Una poltroncina perfetta per creare una zona lettura elegante, dove accomodarsi e concedersi del tempo per sé.

EN A high seat and a curved backrest provide extreme comfort. The perfect armchair for an elegant reading corner and time out for yourself.

DIMENSIONI dimensions

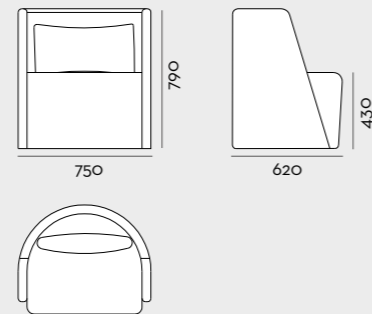

FINITURE finishes

Tessuti - Tessuti Lino - Ecopelli - Ecopelli Gold
Fabrics - Flax fabric - Eco-leathers - Gold eco-leathers

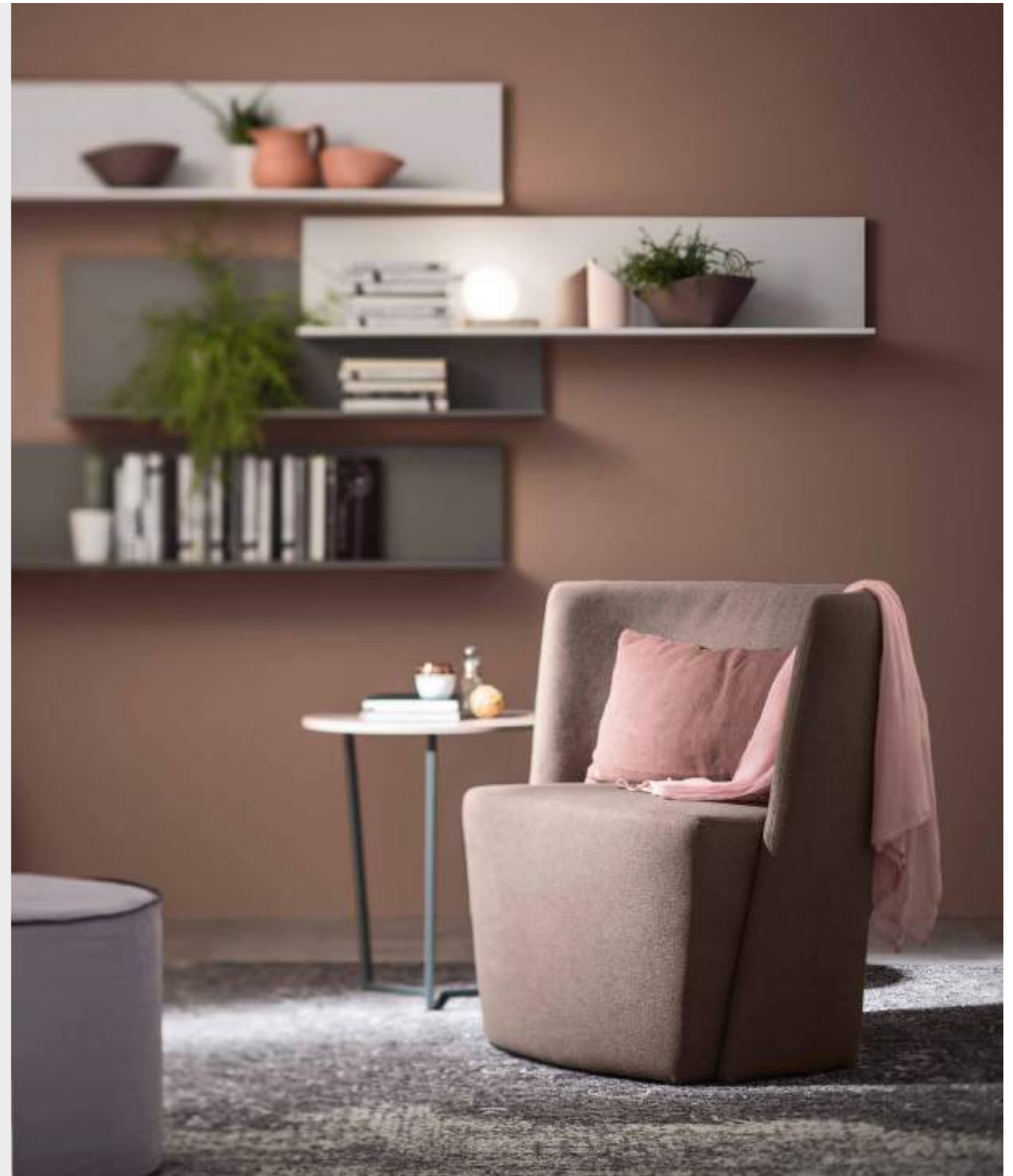

Armchair **Met**

Poltroncina seduta H 390 mm

Armchair seat H 390 mm
↑

IT La seduta ampia, i braccioli alti e il cuscino come schienale danno forma a una poltrona voluminosa nelle dimensioni e nella comodità. Bella da sola ma anche in coppia per arredare un'area conversazione.

EN The broad seat, high armrests, and cushion backrest give volume and comfort to this armchair. Stunning on its own or as a pair in a conversation area.

DIMENSIONI dimensions

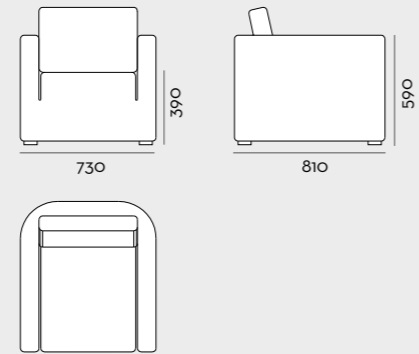

FINITURE finishes

Tessuti - Tessuti Lino - Ecopelli - Ecopelli Gold
Fabrics - Flax fabric - Eco-leathers - Gold eco-leathers



Tessuto Lino / Flax Fabric
Planet 549

Poltroncina Met

Armchair **Nizza**

Poltroncina seduta H 460 mm

Armchair seat H 460 mm

IT Lo schienale avvolge la seduta e dà forma anche ai braccioli dalle linee arrotondate. La poltrona ha una silhouette elegante e uno stile raffinato, che arredano con gusto lo spazio circostante.

EN The backrest wraps around the seat and descends to form curved armrests. This armchair has elegant contours and refined style that add a touch of class to its setting.

DIMENSIONI dimensions

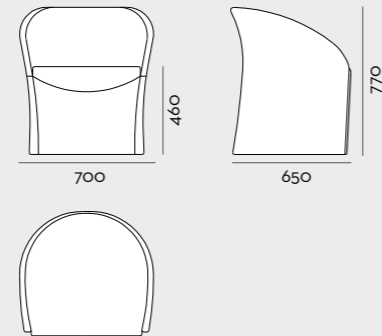

FINITURE finishes

Tessuti - Tessuti Lino - Ecopelli - Ecopelli Gold
Fabrics - Flax fabric - Eco-leathers - Gold eco-leathers



Armchair **Zalea**

Poltroncina seduta H 460 mm

Armchair seat H 460 mm



IT Il design della poltroncina evoca un vero abbraccio: i braccioli si stringono attorno alla seduta e avvolgono chi si accomoda tra le sue forme. In coppia, è l'ideale per creare una zona conversazione accogliente.

EN The design is reminiscent of a real embrace. Armrests wrap around the seat and charmingly hug the occupant of this armchair. A pair is ideal for an inviting conversation area.

DIMENSIONI dimensions

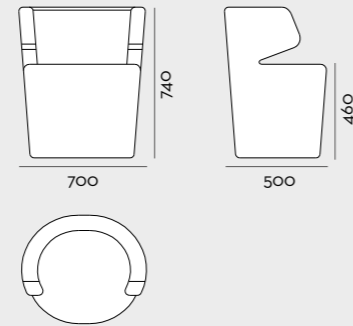

FINITURE finishes

Tessuti - Tessuti Lino - Ecopelli - Ecopelli Gold
Fabrics - Flax fabric - Eco-leathers - Gold eco-leathers



Armchair **Guest**

Poltroncina seduta H 460 mm

Armchair seat H 460 mm

IT Lo schienale racchiude la seduta anche ai lati, i volumi sono pieni e le forme morbide: la poltrona completa lo stile di una camera da letto o di una zona giorno con sobrietà ed eleganza.

EN The backrest envelopes the seat around the sides, the volumes are full and the forms are soft. This armchair adds elegant style to a bedroom or a living area.

DIMENSIONI dimensions

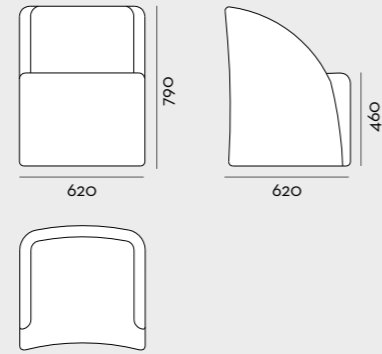

FINITURE finishes

Tessuti - Tessuti Lino - Ecopelli - Ecopelli Gold
Fabrics - Flax fabric - Eco-leathers - Gold eco-leathers



Armchair **Asia**

Poltroncina seduta H 460 mm

Armchair seat H 460 mm
↑

IT Un po' poltroncina e un po' pouf, un complemento perfetto per la cabina armadio: sullo schienale alto possono trovare posto gli abiti e anche la seduta diventa un pratico punto di appoggio, oltre che di relax.

EN Halfway between an armchair and a pouf, this is the perfect accessory for a dressing area. The high backrest has room for clothes and the seat also offers practical space, as well as somewhere to relax.

DIMENSIONI dimensions

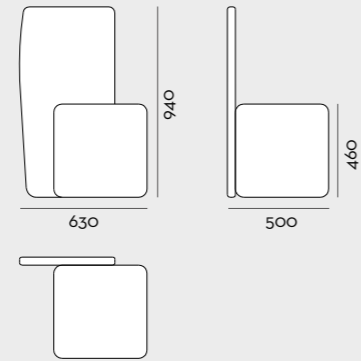

FINITURE finishes

Tessuti - Tessuti Lino - Ecopelli - Ecopelli Gold
Fabrics - Flax fabric - Eco-leathers - Gold eco-leathers



Pouf / Cuscini

Cucitura a filo

Thread stitching ↑

IT Tondeggianti o squadrati, disponibili con tanti rivestimenti e in tanti colori: singolarmente o in gruppo, i pouf portano colore e comodità in qualunque ambiente della casa, dal living alla camera da letto.

EN Round or square and available in a variety of coverings and colours. Whether alone or in a group, poufs add colour and comfort to any space in the house, from the living area to the bedroom.

POUF

THUBO

Pouf tondi con cucitura a filo
Round pouf with overlock stitching

SL073



SL072



DADO

Pouf quadrati con cucitura a filo
Square pouf with overlock stitching

SL074

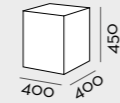

SL076

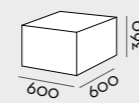

SL078

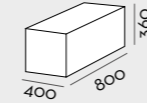

SL079

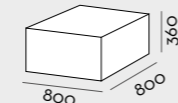

BOTTE

Pouf maniglia effetto cuoio
Pouf with leather handle

SL040



CUSCINI cushions

THEDDY

SL061



SL063



SL062

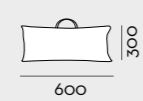

FINITURE finishes

Tessuti - Tessuti Lino - Ecopelli - Ecopelli Gold

Fabrics - Flax fabric - Eco-leathers - Gold eco-leathers



POUF MULTIFUNZIONALI

^{IT} Sedute e piani d'appoggio, allo stesso tempo: i pouf rettangolari hanno una forma perfetta per portare comodità, praticità e stile nel medesimo spazio.

^{EN} They're both somewhere to sit and somewhere to rest things. Rectangular poufs offer the perfect shape for comfort, style and practical living, all in the same space.

Multifunctional poufs ↑



Pouf Dado
L 400 x P 800 x H 360 mm (sx)
L 800 x P 800 x H 360 mm (dx)

Tessuto / Fabric
Rally 602





Coffee tables
↓

PICCOLI
PIANI DI
APPOGGIO
E GRANDI
ARREDI
DI STILE.

Small surfaces and large amounts of style.

Tavolini

Forme e finiture diverse per
adattarsi ad ogni spazio e utilizzo.
Various forms and finishes to adapt
to all spaces and uses.

index

- 317 → Even
- 325 → Soap
- 327 → Capitol
- 333 → Nemo
- 337 → Niko
- 339 → Icaro
- 343 → Dress Holders



UN'AMPIA COLLEZIONE

IT Come pratici piani d'appoggio o come semplici elementi decorativi, i tavolini trovano posto facilmente in ogni ambiente della casa.

EN Coffee tables find a practical use in any room of the home, whether as somewhere to rest things or as items of decorative furniture.

A wide collection ↑

Tables **Even**

Tavolini con basamento in metallo

IT Tre altezze per il basamento e tre diametri per il piano: il tavolino è disponibile in più finiture, colori e dimensioni per creare abbinamenti personalizzati e dare funzioni diverse ai singoli complementi.

EN Three heights for the base and three diameters for the top. This coffee table is available in several finishes, colours and dimensions to deliver personalised combinations and create different functions for each piece.

Coffee tables with metal base ↑

DIMENSIONI dimensions

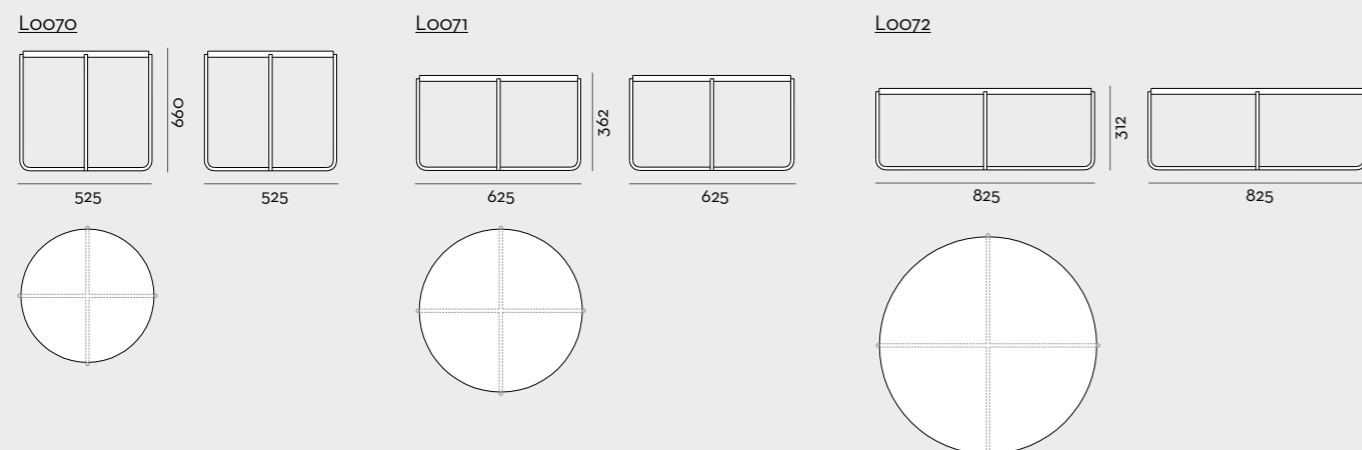

PIANO top

Melaminici Melamine

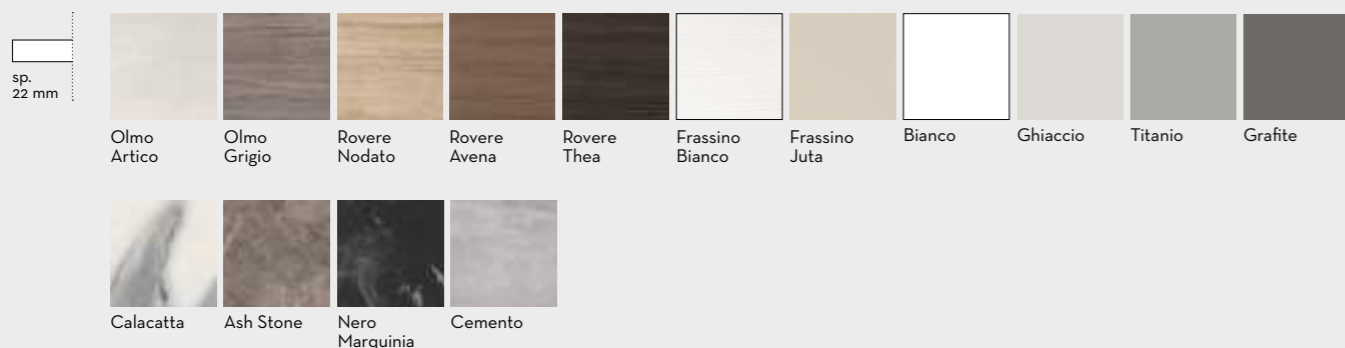

Laccati lucidi e opachi in tutti i colori della mazzetta - Frassino colore laccato in tutti i colori della mazzetta - Stampe con grafiche
Glossy and matt colour lacquered all the sample colours - Colour lacquered ash all the sample colours - Prints with designs

BASAMENTO base

Metallo laccato in tutti i colori della mazzetta
Metal legs lacquered in all fan-deck colours



Basamento Laccato opaco / Matt Lacquered base
Ottone

Top Laccato opaco / Matt Lacquered top
Cenero

Tavolino Even
LO070



→

IT Con la tecnica della stampa in digitale, sulla superficie dei tavolini vengono stampate texture e grafiche: un rivestimento molto originale, in alternativa o in abbinamento al colore pieno o ad altre finiture. Oltre a essere un pratico piano d'appoggio, il tavolino diventa anche molto decorativo.

EN Textures and digitally printed graphic designs are applied to the surface of these coffee tables. An original solution as an alternative to or in combination with solid colours or other finishes. Practicality alongside decorative design.



↑ **Tavolino Even L0072 - Stampa "Elegance 04A" /
Coffee table L0072 - "04A Elegance" stamp**

Tables **Even**

Tavolini con basamento in metallo

Coffee tables with metal base ↑

IT Il tavolino quadrato è disponibile in tre dimensioni, tre altezze e tanti rivestimenti. Effetto legno, marmo o cemento, colori e stampe caratterizzano il tavolino e anche lo spazio circostante.

EN The square coffee table is available in three sizes, three heights and several finishes. Wood, marble or cement effects, colours or prints are the order of the day for the table and its setting.

DIMENSIONI dimensions

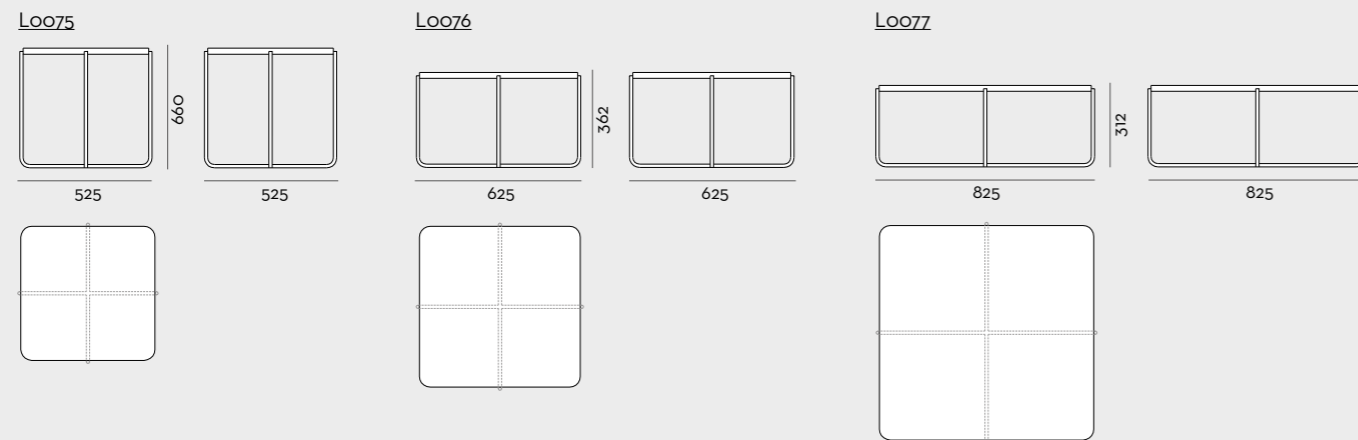

PIANO top

Melaminici Melamine

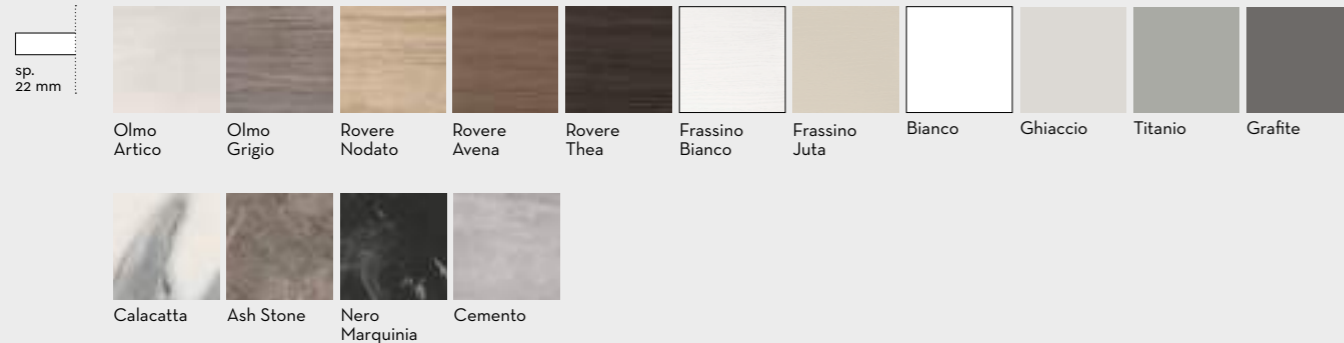

Laccati lucidi e opachi in tutti i colori della mazzetta - Frassino colore laccato in tutti i colori della mazzetta - Stampe con grafiche
Glossy and matt colour lacquered all the sample colours - Colour lacquered ash all the sample colours - Prints with designs

BASAMENTO base

Metallo laccato in tutti i colori della mazzetta
Metal legs lacquered in all fan-deck colours



Basamento Laccato opaco / Matt Lacquered base
Nero

Top Laccato opaco / Matt Lacquered top
(sx) Cipria - (dx) Porpora

Tavolino Even
(sx) L0075 - (dx) L0077

Tables Soap

Tavolini con basamento in metallo

IT Le gambe in metallo colorato sostengono un tavolino dalla forma particolare, disponibile in tante finiture e molteplici colori. Due altezze e due dimensioni per creare originali composizioni.

EN Coloured metal legs provide support for a table with an original design, available in several colours and finishes. Two heights and two sizes to create original compositions.

Coffee tables with metal base

DIMENSIONI dimensions

L0073

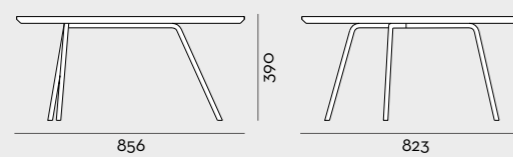

L0074

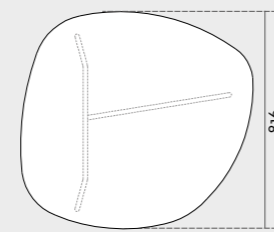
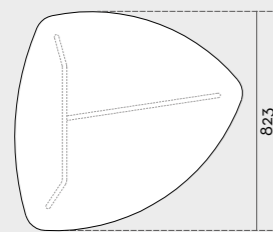
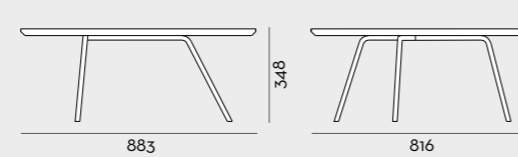

PIANO top

Melaminici Melamine

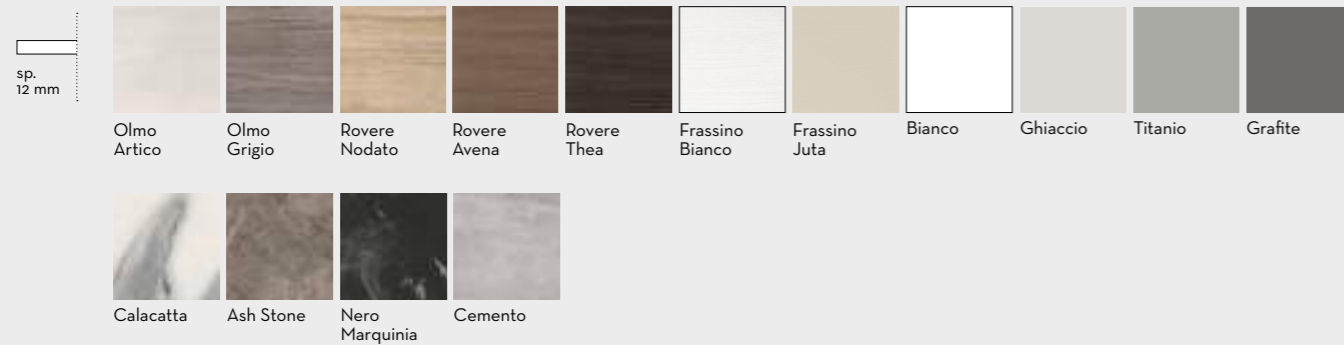

Laccati lucidi e opachi in tutti i colori della mazzetta - Frassino colore laccato in tutti i colori della mazzetta - Stampe con grafiche
Glossy and matt colour lacquered all the sample colours - Colour lacquered ash all the sample colours - Prints with designs

BASAMENTO base

Metallo laccato in tutti i colori della mazzetta
Metal legs lacquered in all fan-deck colours

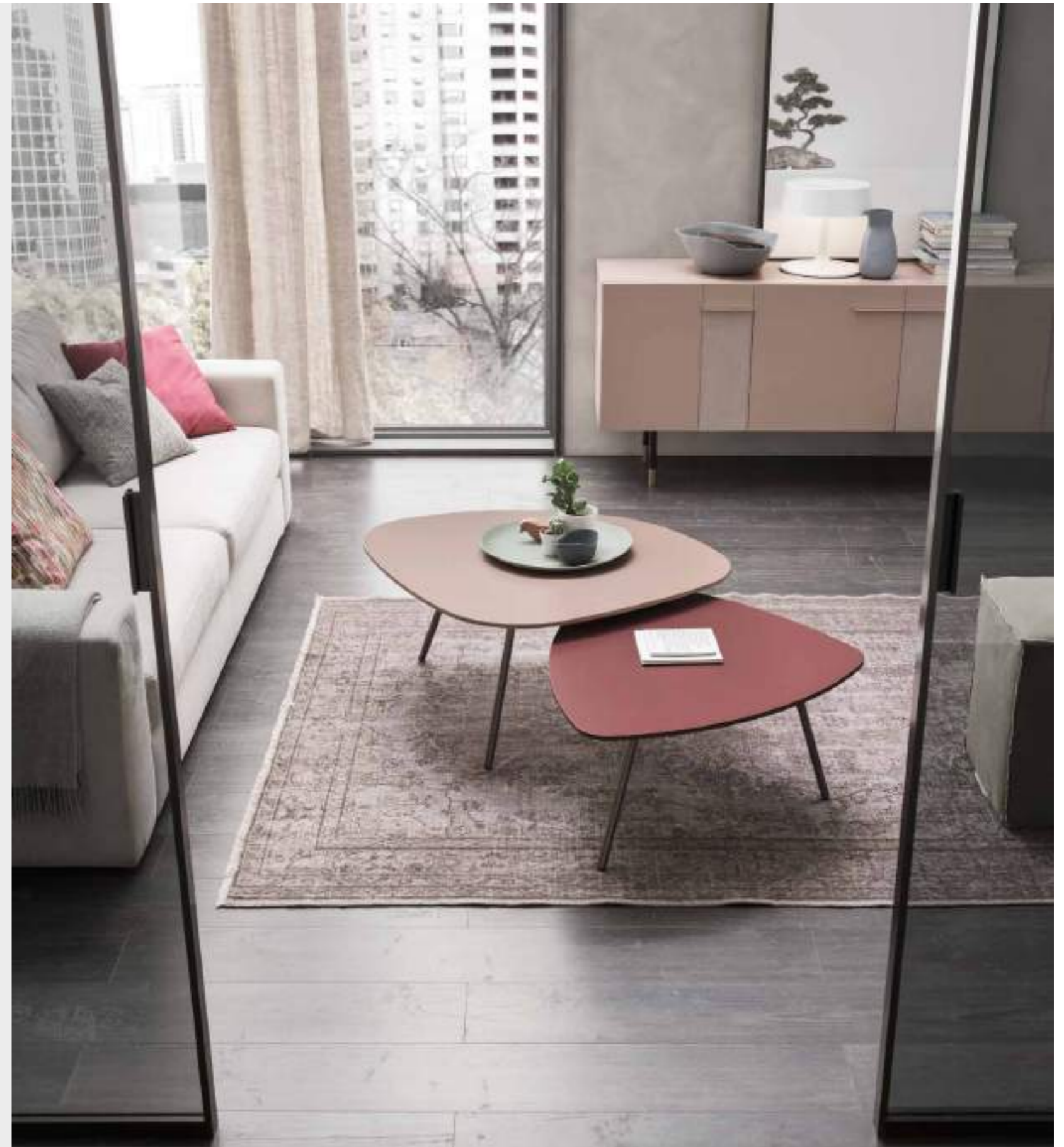

Basamento Laccato opaco / Matt Lacquered base
Bronzo

Top Laccato opaco / Matt Lacquered top
(sx) Cipria - (dx) Porpora

Tavolino Soap
(sx) L0073 - (dx) L0074

Tables Capitol

Tavolini con basamento in metallo

IT Il basamento è formato da tondini in metallo che sostengono un piano realizzabile in molte finiture, colori e grafiche, anche in ecopelle. Gli angoli arrotondati annullano gli spigoli ed esaltano lo stile.

EN Metal rods make up the base supporting a top available in several finishes, colours and printed designs, including faux leather. Sharp corners are rounded and style is given pride of place.

Coffee tables with metal base

DIMENSIONI dimensions

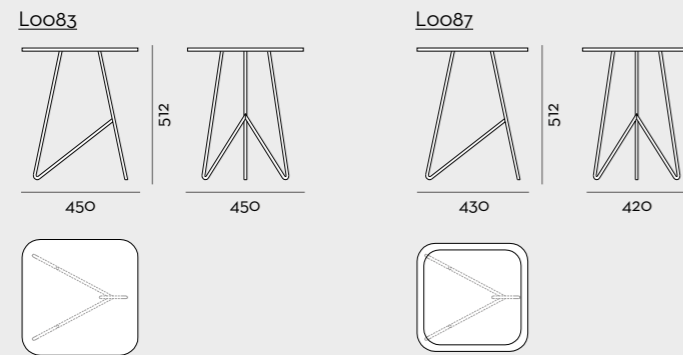

PIANO top

Melaminici Melamine

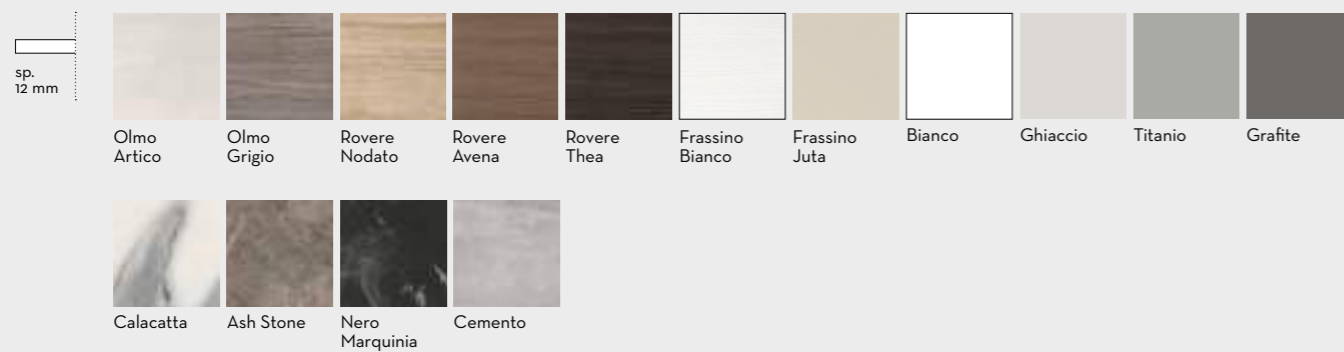

Laccati lucidi e opachi in tutti i colori della mazzetta - Frassino colore laccato in tutti i colori della mazzetta - Stampe con grafiche
Glossy and matt colour lacquered all the sample colours - Colour lacquered ash all the sample colours - Prints with designs

PIANO solo Loo87 only Loo87 top

Ecopelli - Ecopelli Gold vedi pagina 417 - 419 Eco-leathers - Gold eco-leathers see page 417 - 419

BASAMENTO base

Metallo laccato in tutti i colori della mazzetta Metal legs lacquered in all fan-deck colours



Basamento Laccato opaco / Matt Lacquered base
(sx) Nero - (dx) Bianco

Top Melaminico / Melamine top
(dx) Rovere Thea

Top Ecopelle / Eco-leather top
(sx) Grigio Perla

Tavolino Capitol
(sx) Loo87 - (dx) Loo83



IT Il tavolino in ecopelle riproduce la forma di un vassoio, per questo è perfetto da inserire nel living, vicino a un divano, dove accogliere gli ospiti sorseggiando un buon caffè. Abbinato a un altro tavolino con una finitura diversa, la funzionalità e lo stile raddoppiano nello stesso spazio.

EN The faux leather table reproduces the form of a tray, making it the perfect companion to a sofa for when guests come round for coffee. Combine with another table in a different finish for twice the functionality and style.



↑ Top Melaminico Rovere Thea e ecopelle Grigio Perla /
Thea oak melamine and Grigio Perla eco-leathers tops

Tables Capitol

Tavolini con basamento in metallo

Coffee tables with metal base

IT Il tavolino rotondo ha un basamento in metallo e un piano che può essere rivestito con effetti legno, marmo o cemento, può essere colorato o addirittura stampato. Massima personalizzazione.

EN Round coffee table with a metal base and a top that can have a wood, marble or concrete effect finish, and be coloured or feature a printed design. Numerous personalisation options.

DIMENSIONI dimensions

LOO86

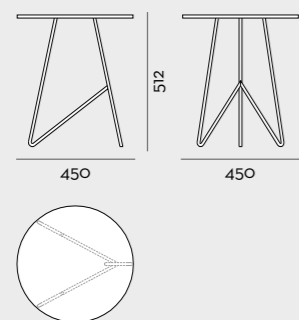

PIANO top

Melaminici Melamine

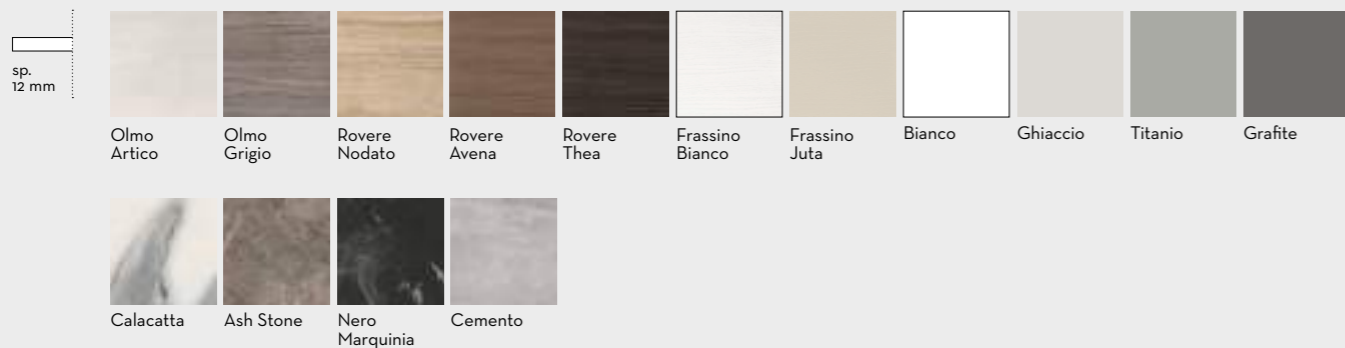

Laccati lucidi e opachi in tutti i colori della mazzetta - Frassino colore laccato in tutti i colori della mazzetta - Stampe con grafiche
Glossy and matt colour lacquered all the sample colours - Colour lacquered ash all the sample colours - Prints with designs

BASAMENTO base

Metallo laccato in tutti i colori della mazzetta
Metal legs lacquered in all fan-deck colours



Basamento Laccato opaco / Matt Lacquered base
Nero

Top grafica / Graphic top
Inide B/N

Tavolino Capitol
LOO86

Tables **Nemo**

Tavolini con basamento in metallo

IT Il basamento alto dalle linee dritte e squadrate sostiene un piano perfettamente rotondo. Un gioco di geometrie, ma anche di abbinamenti di colori e finiture per coordinare il tavolino agli altri arredi.

EN The high base with square straight lines supports a perfectly round top. Combine geometries, colours and finishes to coordinate the table with other furniture.

Coffee tables with metal base ↑

DIMENSIONI dimensions

LOO82

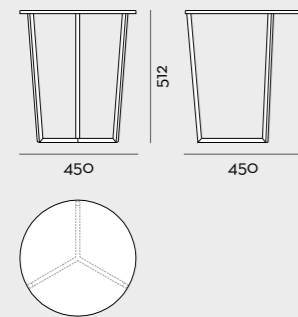

PIANO top

Melaminici Melamine

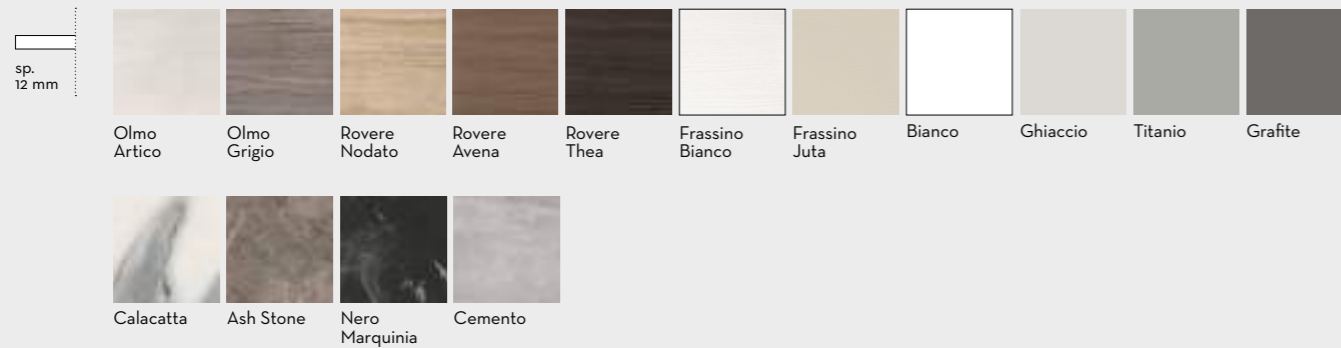

Laccati lucidi e opachi in tutti i colori della mazzetta - Frassino colore laccato in tutti i colori della mazzetta - Stampe con grafiche
Glossy and matt colour lacquered all the sample colours - Colour lacquered ash all the sample colours - Prints with designs

BASAMENTO base

Metallo laccato in tutti i colori della mazzetta
Metal legs lacquered in all fan-deck colours

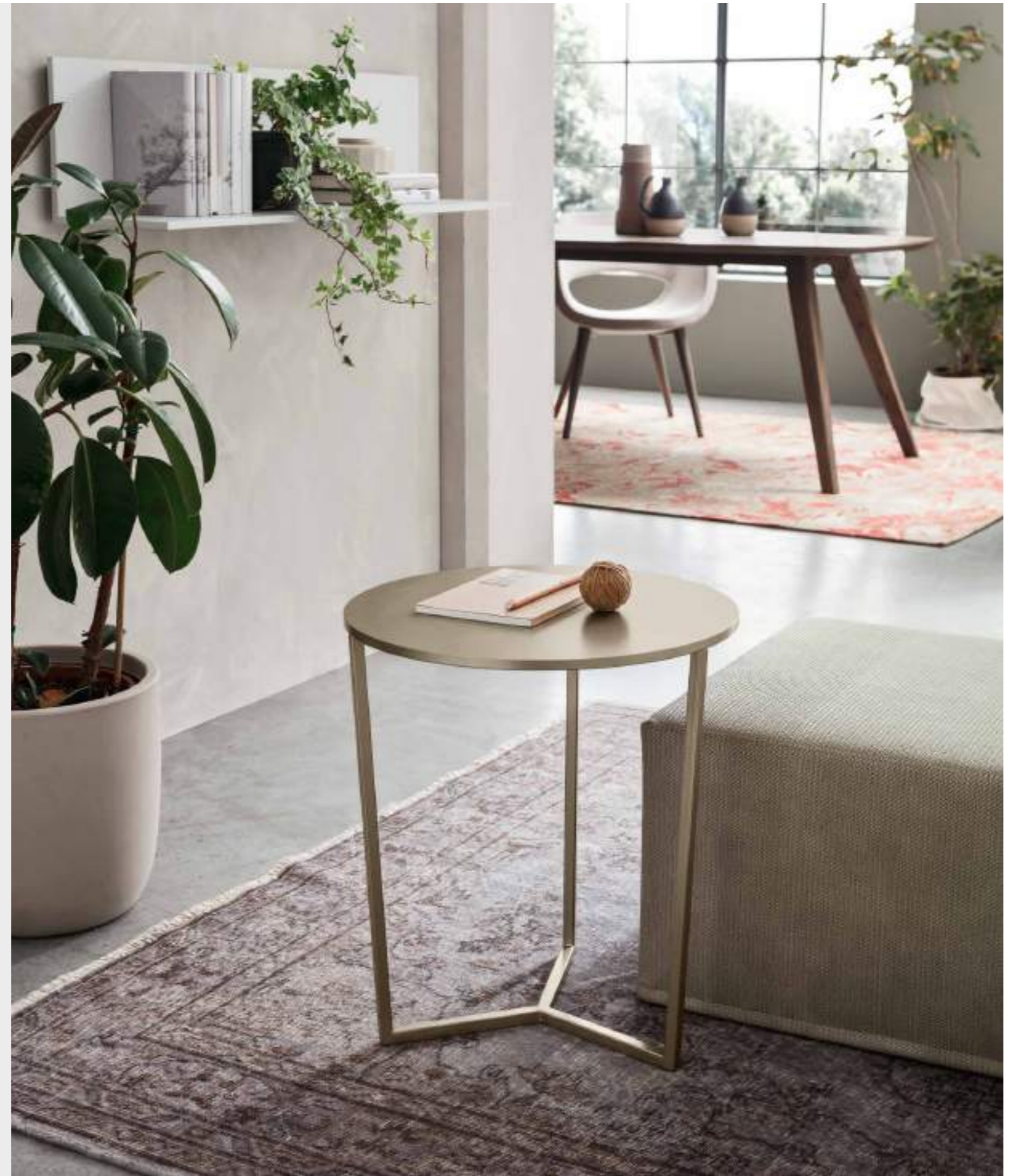

Tables **Nemo**

Tavolini con basamento in metallo

IT Il tavolino basso è personalizzabile con effetti legno, marmo o cemento, oppure con colori e stampe. Le sue dimensioni sono ideali per posizionarlo di fronte a un divano, anche abbinato alla versione alta.

EN A low coffee table that can be personalised with wood, marble or cement effects, colours or printed designs. The perfect size to go in front of a sofa, especially when combined with the tall version.

Coffee tables with metal base ↑

DIMENSIONI dimensions

LOO84

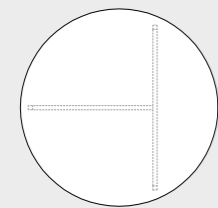
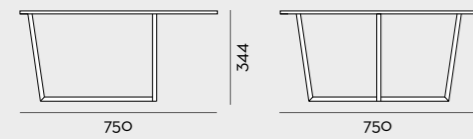

PIANO top

Melaminici Melamine

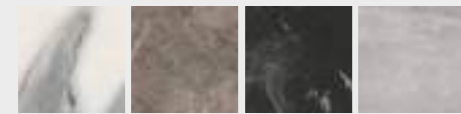

Laccati lucidi e opachi in tutti i colori della mazzetta - Frassino colore laccato in tutti i colori della mazzetta - Stampe con grafiche
Glossy and matt colour lacquered all the sample colours - Colour lacquered ash all the sample colours - Prints with designs

BASAMENTO base

Metallo laccato in tutti i colori della mazzetta
Metal legs lacquered in all fan-deck colours



Tables **Niko**

Tavolini con basamento in metallo

IT Basamento e piano condividono la forma rotonda ma possono avere finiture e colori diversi. Un tavolino che trova spazio a lato di un divano o di una poltrona per appoggiare tutto ciò che serve.

EN Base and top share the same round shape but can feature different combinations of finishes and colours. A convenient place to keep things when placed next to a sofa or armchair.

Coffee tables with metal base ↑

DIMENSIONI dimensions

LOO28

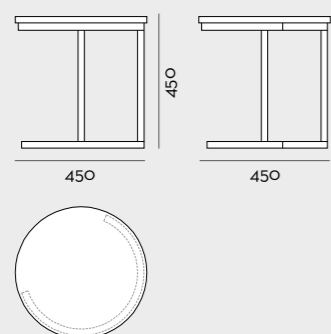

LOO29

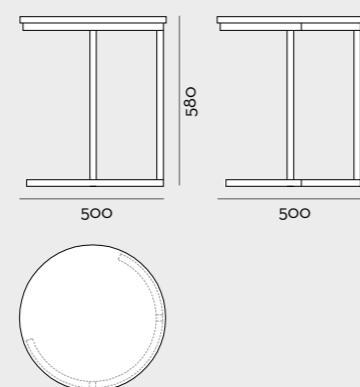

PIANO top

Melaminici Melamine

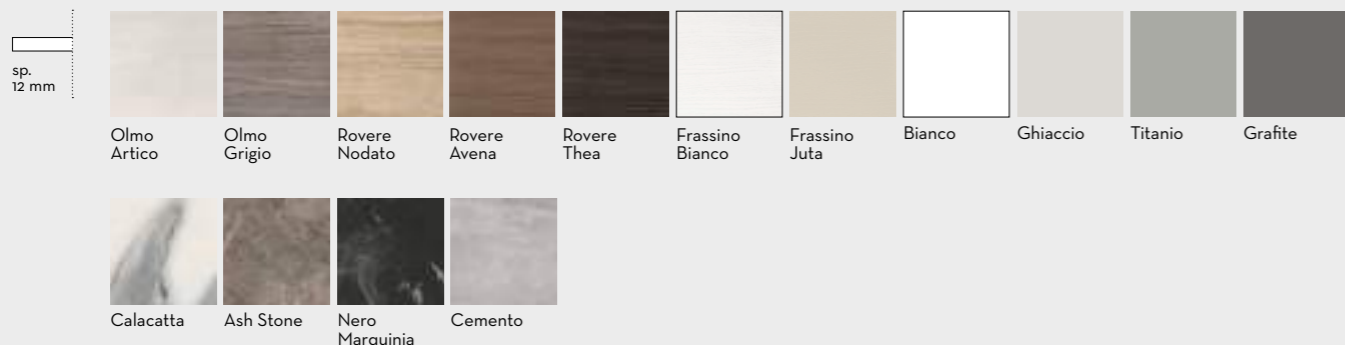

Laccati lucidi e opachi in tutti i colori della mazzetta - Frassino colore laccato in tutti i colori della mazzetta - Stampe con grafiche
Glossy and matt colour lacquered all the sample colours - Colour lacquered ash all the sample colours - Prints with designs

BASAMENTO base

Metallo laccato in tutti i colori della mazzetta
Metal legs lacquered in all fan-deck colours



Basamento Laccato opaco / Matt Lacquered base
Nichel

Top Laccato opaco / Matt Lacquered top
Castagno

Tavolino Niko
LOO29

Table Icaro

Tavolino da salotto

Coffee table living room ↑

IT Il basamento in vetro sostiene un piano in essenza, effetti marmo e cemento, rovere massiccio e colori laccati. Grazie alle sue dimensioni, il tavolino trova il suo posto ideale di fronte al divano.

EN A glass base supports a top available in wood, marble or concrete effect, solid oak or lacquered. The table is the ideal size for placing in front of the sofa.

DIMENSIONI dimensions

L1050

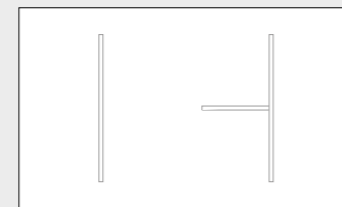
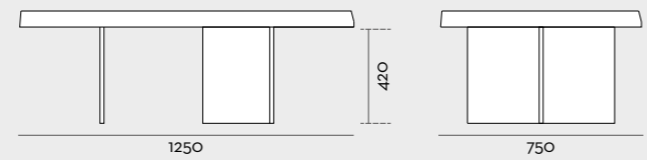

PIANO top

Melaminici Melamine



Melaminici Melamine

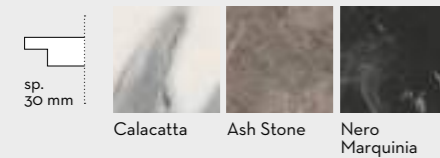

Rovere massiccio Solid oak



Frassino Olivato massiccio Solid Olive Ash

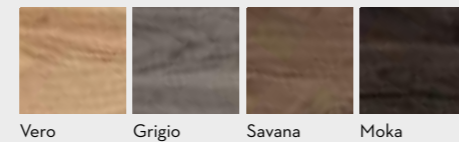

STRUTTURA frame

Vetro Glass

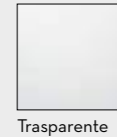

Trasparente



Basamento vetro / Glass base
Trasparente

Piano Rovere massiccio / Solid Oak top
Vero

Tavolino Icaro
L1050



Il piano in legno massiccio è perfetto anche per caratterizzare il tavolino da salotto, magari in abbinamento al tavolo grande della sala da pranzo. Un complemento d'arredo d'impatto, per i materiali che lo compongono e per il volume importante, alleggerito con stile dal basamento in vetro.

The solid wood top is perfect for a living room coffee table, or even coordinated with a large dining room table. The materials and large dimensions of this stunning table are stylishly offset by the lightness of its glass base.



↑ **Rovere Massiccio / Solid Oak**
Vero

Dress holders

Appendiabiti in metallo

Metal clothes stand ↑

IT I porta abiti hanno una struttura in metallo colorato e piani personalizzabili in varie finiture e colori. Sono complementi molto utili in camera da letto o nelle cabine armadio, per tenere tutto in ordine con stile.

EN These dress holders feature a coloured metal frame and shelves that can be personalised with various finishes and colours. Useful to ensure order and style in bedrooms and dressing areas.

DIMENSIONI dimensions

CAMILA SL018

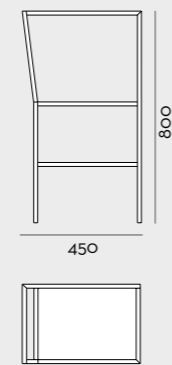

OTIS AP010

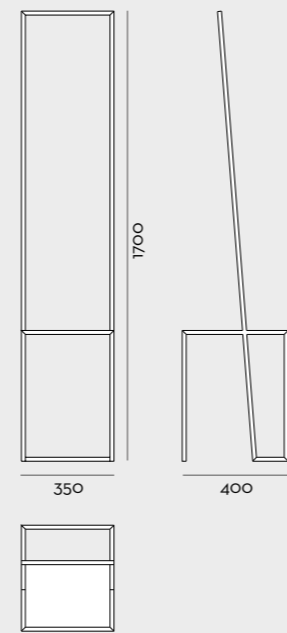

PIANO top

Melaminici Melamine

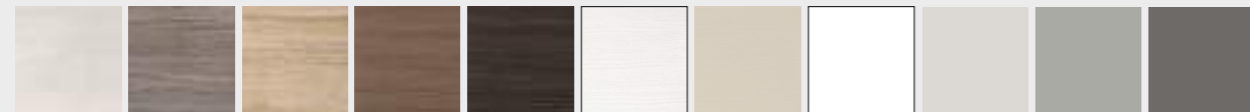

Olmo Artico Olmo Grigio Rovere Nodato Rovere Avena Rovere Thea Frassino Bianco Frassino Juta Bianco Ghiaccio Titanio Grafite

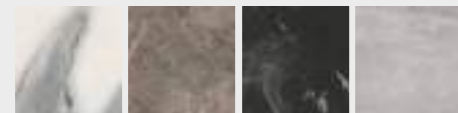

Calacatta Ash Stone Nero Marquinia Cemento

Laccati lucidi e opachi in tutti i colori della mazzetta - Frassino colore laccato in tutti i colori della mazzetta
Glossy and matt colour lacquered all the sample colours - Colour lacquered ash all the sample colours

STRUTTURA frame

Metallo laccato in tutti i colori della mazzetta
Metal legs lacquered in all fan-deck colours



Basamento Laccato opaco / Matt Lacquered base
Bianco

Top Melaminico / Melamine top
(dx) Rovere Thea

Top Laccato opaco / Matt Lacquered top
(sx) Juta

Dress holders
(sx) AP010 - (dx) SL018

Accessories



DANNO
UN TOCCO
DI STILE
O DI LUCE
IN PIÙ
ALL'AMBIENTE.

An added hint of style or light.

Accessori

Tanti elementi diversi per valorizzare
la parete o completare lo spazio.
So many ways to enhance walls
and spaces.

index

- 347 → **Mensole** shelves
- 369 → **Specchiere** mirrors
- 379 → **Panchette** benches
- 383 → **Lampade** lamps

Shelves **Elle**

Mensole LED con schiena

LED shelves with back panel
↑

IT Pratica e scenografica, la mensola retroilluminata è disponibile in più lunghezze e può essere fissata rivolta verso l'alto o verso il basso. Tante finiture per abbinarla al resto dell'arredo.

EN This practical and eye-catching backlit shelf is available in several lengths and can be facing up or down. So many opportunities for coordinating finishes with the rest of the furniture.

STRUTTURA frame

Melaminici Melamine

Rovere impiallacciato Veneer oak

Laccati lucidi e opachi in tutti i colori della mazzetta
Glossy and matt colour lacquered all the sample colours

Frassino colore laccato in tutti i colori della mazzetta
Colour lacquered ash all the sample colours

DIMENSIONI dimensions

L 1056 - 1232 - 1408 - 1760 - 1936 - 2112 mm

P 250 mm

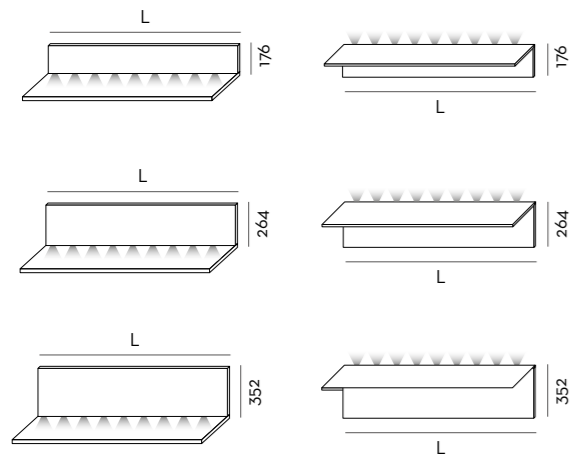

Shelves **Elle composta**

Mensole composte con schiena

IT Le mensole possono essere composte tra di loro per creare un effetto boiserie sulla parete. La forma sagomata permette di integrare le mensole ai pensili e di dare un senso di continuità agli arredi.

EN These shelves can be arranged to create a panelled wall effect. The contoured shape of the shelves allows them to be integrated with the wall units providing a sense of continuity.

Modular shelves with back panel

STRUTTURA frame

Melaminici Melamine

Rovere impiallacciato Veneer oak

Laccati lucidi e opachi in tutti i colori della mazzetta
Glossy and matt colour lacquered all the sample colours

Frassino colore laccato in tutti i colori della mazzetta
Colour lacquered ash all the sample colours

DIMENSIONI dimensions

L 1056 - 1232 - 1408 - 1760 - 1936 - 2112 mm

H 176 - 264 - 352 mm

P 250 mm

Taglio in lunghezza (multipli di 176 mm)
Length reduction (in multiples of 176 mm)

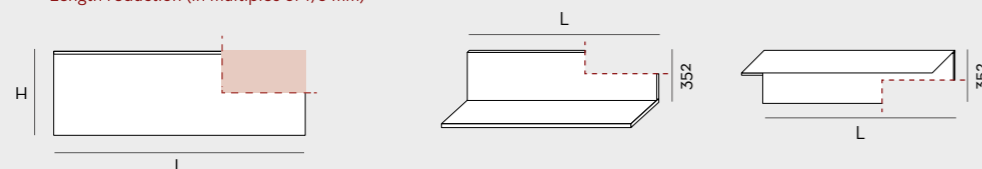



PARETI DECORATE

^{IT} Le mensole hanno differenti altezze e lunghezze: in questo modo possono essere abbinate tra di loro per creare originali composizioni.

^{EN} Shelves of different heights and lengths can be combined to create original compositions.

Decorated walls ↑

Shelves **Zig Zag**

Mensola con schienale in metallo

Metal shelves with back panel
↑

IT Con il suo design originale, la mensola lascia il segno sulla parete. Il movimento a zig zag, da cui prende il nome, è sicuramente il suo tratto distintivo, che può essere valorizzato da tante finiture e colori.

EN The original design of these shelves won't go unnoticed on walls. The distinctive zigzag pattern that gives them their name can be further enhanced with a variety of finishes and colours.

STRUTTURA frame

Melaminici (escluso Rovere Nodato - Cemento - Calacatta - Ash Stone - Nero Marquinia)
Melamine (excluding Knotted oak - Cement - Calacatta - Ash Stone - Nero Marquinia)

Rovere impiallacciato Veneer oak

Laccati lucidi e opachi in tutti i colori della mazzetta
Glossy and matt colour lacquered all the sample colours

Frassino colore laccato in tutti i colori della mazzetta
Colour lacquered ash all the sample colours

* SCHIENALE back panel

Metallo laccato in tutti i colori della mazzetta
Metal legs lacquered in all fan-deck colours

DIMENSIONI dimensions

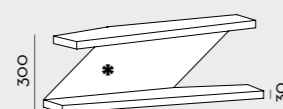
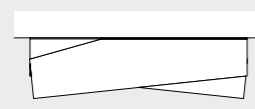

Shelves **Box**

Mensole scatolate con struttura in vetro

IT La particolare forma sagomata della mensola, le permette di integrarsi ai pensili. La struttura è in vetro e la schiena è personalizzabile in diverse finiture e più colori: perfetta per contenere e decorare.

EN The contoured design of these shelves allow them to be integrated into wall units. The structure is glass and the back panel can be personalised with a variety of finishes and colours: perfect for storage and decorations.

Boxed shelves with glass frame

STRUTTURA frame

Vetro trasparente Transparent glass

* SCHIENALE back panel

Melaminici (escluso Calacatta - Ash Stone - Nero Marquinia)

Melamine (excluding Calacatta - Ash Stone - Nero Marquinia)

Rovere impiallacciato Veneer oak

Laccati lucidi e opachi in tutti i colori della mazzetta

Glossy and matt colour lacquered all the sample colours

Frassino colore laccato in tutti i colori della mazzetta

Colour lacquered ash all the sample colours

COMPONIBILITÀ componibilità

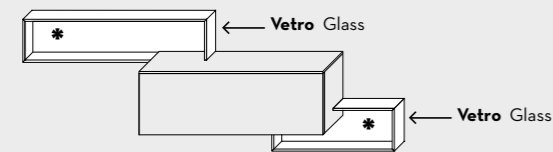

DIMENSIONI dimensions

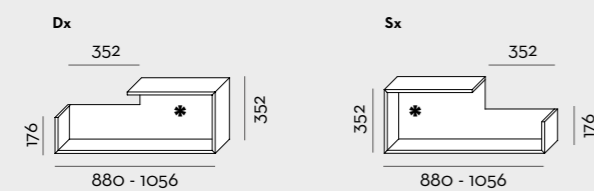



MENSOLA INTEGRATA

IT La mensola si inserisce nei pensili o nelle madie e diventa un tutt'uno con il resto dell'arredo. Una soluzione per dare movimento alle composizioni.

EN This shelf can be integrated into sideboards or wall units and coordinate with other furniture. A solution to create energy in compositions.

Integrated shelf ↑

COPPIA DI MENSOLE

^{IT} Le mensole possono essere disposte in modo da formare un'unica mensola. In questo caso i fianchi in vetro diventano dei pratici divisori.

^{EN} These shelves can be arranged to form a single shelf. Thus, their glass sides become practical dividers.

Pair of shelves
↑



Shelves **Rebel**

Mensole scatolate

IT Le mensole scatolate sono personalizzabili in ogni dettaglio: struttura, schiena, dimensione e componibilità. Combinate tra di loro arredano e decorano con originalità qualsiasi parete di casa.

EN Every detail of these boxed shelves can be personalised: frame, back panel, size and modules. When combined they provide an original decorative feature for any wall in the home.

Boxed shelves ↑

STRUTTURA frame

Melaminici Melamine
Rovere impiallacciato Veneer oak

* SCHIENALE back panel

Melaminici (escluso Calacatta - Ash Stone - Nero Marquinia)
Melamine (excluding Calacatta - Ash Stone - Nero Marquinia)

Rovere impiallacciato Veneer oak

Laccati opachi in tutti i colori della mazzetta
Matt colour lacquered all the sample colours

Frassino colore laccato in tutti i colori della mazzetta
Colour lacquered ash all the sample colours

COMPONIBILITÀ componibilità

Esempio 01 Example 01



Esempio 02 Example 02

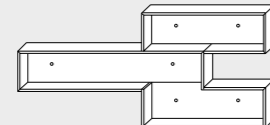

DIMENSIONI dimensions

L **528 - 704 - 1056 - 1232 - 1408 mm**
H **246 mm**
P **250 mm**

Dx

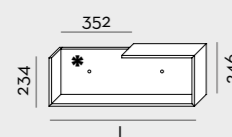

Sx

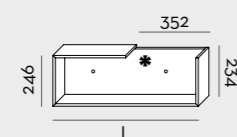

Shelves **Lux**

Mensole con LED

Shelves with LED
↑

IT Una mensola formata da un piano di appoggio, una cornice decorativa in metallo e uno schienale personalizzabile in diverse finiture e più colori. La luce integrata mette ulteriormente in risalto il design.

EN A shelf consisting of a support surface, a decorative metal frame and a back panel that can be personalised with a variety of finishes and colours. The integrated light further enhances the design.

STRUTTURA frame

Metallo laccato Bronzo - Ottone - Nichel - Ferro - Nero - Bianco
Metal lacquered in Bronze - Brass - Nickel - Iron - Black - White

SCHIENALE back panel

Melaminici Melamine

Rovere impiallacciato Veneer oak

Laccati lucidi e opachi in tutti i colori della mazzetta
Glossy and matt colour lacquered all the sample colours

Frassino colore laccato in tutti i colori della mazzetta
Colour lacquered ash all the sample colours

Finiture Decor
Decor finishes

DIMENSIONI dimensions

P 225 mm

Dx

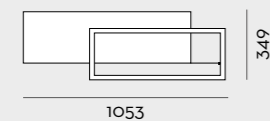

1053

349

Dx

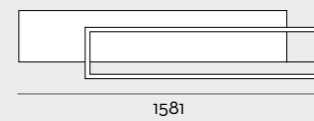

1581

349

Sx

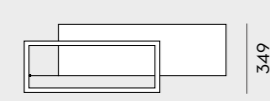

1053

349

Sx

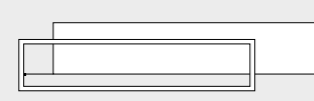

1581

349



Shelves **Lux**

Mensola con LED

Shelves with LED
↑

IT Nella sua versione verticale, la mensola si compone di più piani di appoggio in metallo. La struttura e lo schienale sono personalizzabili per abbinarsi allo stile dell'arredo e la luce crea un effetto scenografico.

EN The vertical version of the shelf consists of two metal support surfaces. The frame and the back panel can be personalised to coordinate with the setting and the light creates a stunning effect.

STRUTTURA frame

Metallo laccato Bronzo - Ottone - Nichel - Ferro - Nero - Bianco
Metal lacquered in Bronze - Brass - Nickel - Iron - Black - White

SCHIENALE back panel

Melaminici Melamine

Rovere impiallacciato Veneer oak

Laccati lucidi e opachi in tutti i colori della mazzetta
Glossy and matt colour lacquered all the sample colours

Frassino colore laccato in tutti i colori della mazzetta
Colour lacquered ash all the sample colours

Finiture Decor
Decor finishes

DIMENSIONI dimensions

P 225 mm

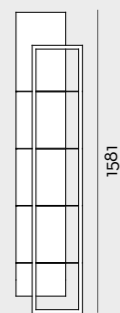

349



Shelves **Scuderia**

Mensole con LED

Shelves with LED ↑

IT La mensola ha un piano di appoggio sottile in metallo e la schiena composta da doghe in legno. La luce integrata è decorativa, ma anche utile per illuminare lo spazio e creare atmosfera.

EN The shelf has a slender metal support surface and the back panel consists of wooden slats. The integrated light is decorative but also practical: it illuminates the space and creates atmosphere.

STRUTTURA frame

Metallo laccato Metal Grey Metal lacquered in Metal Grey

SCHIENALE back panel

Rovere Vero - Grigio - Savana - Moka Vero - Grigio - Savana - Moka oak

DIMENSIONI dimensions

L **1156 - 1332 - 1860 mm**
P **250 mm**

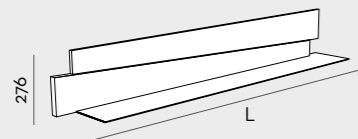

Specchiere

Mirrors



RIFLESSI DI STILE

IT In camera da letto, in zona giorno, in ingresso o in guardaroba, le specchiere sono accessori che decorano e ampliano lo spazio.

EN Mirrors decorate and expand the space in bedrooms, living rooms, hallways and dressing areas.

Reflected style ↑



Mirrors **Lego**

Specchiera filo lucido

Polished edge mirror
↑

IT Lo specchio rettangolare è disponibile in cinque formati diversi e può essere utilizzato da solo o inserito in una composizione, a seconda dello spazio da riempire. L'effetto bronzato è molto attuale e raffinato.

EN The rectangular mirror is available in five different formats and can be used alone or as part of a composition, depending on the space. The bronze effect is current and refined.

FINITURE finishes

Specchio Bronzo filo lucido Polished edge Bronze mirror

DIMENSIONI dimensions

Sp 22 mm

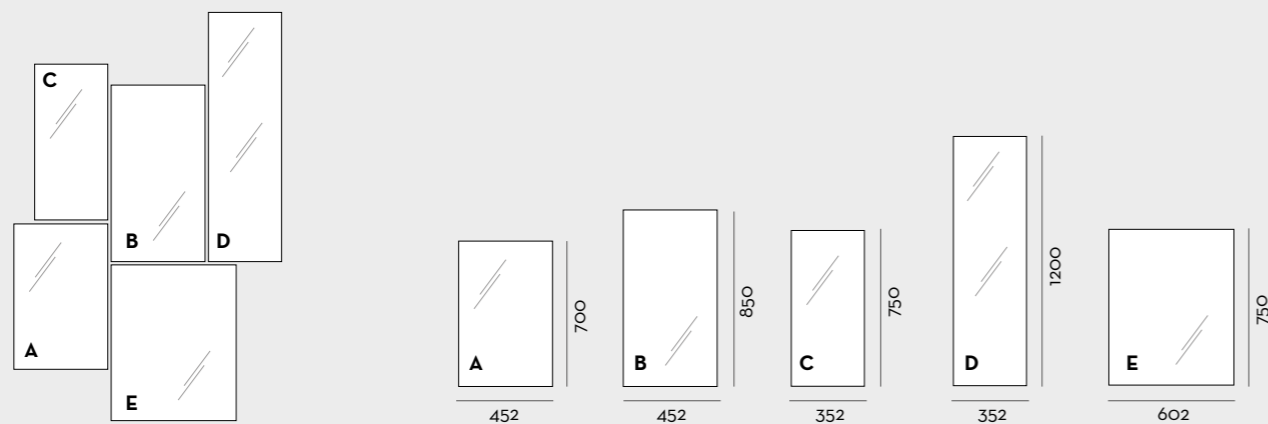

Mirror **Globo**

Specchiera tonda

Round mirror
↑

IT La specchiera tonda è suddivisa in due parti: una parte specchio e una parte rivestita con una particolare finitura Decor. Un accessorio dalla forma semplice ma molto decorativo, per dare un tocco in più alla parete.

EN The round mirror is divided into two parts: a looking glass and a section decorated with a special design finish. A minimal yet highly decorative accessory that adds a touch of class to a wall.



FINITURE finishes

Specchio filo lucido Polished edge mirror

* **Melaminici (escluso Calacatta - Ash Stone - Nero Marquinia)**
Melamine (excluding Calacatta - Ash Stone - Nero Marquinia)

* **Laccati lucidi e opachi in tutti i colori della mazzetta**
Glossy and matt colour lacquered all the sample colours

* **Frassino colore laccato in tutti i colori della mazzetta**
Colour lacquered ash all the sample colours

* **Finiture Decor**
Decor finishes

DIMENSIONI dimensions

Sp 38 mm

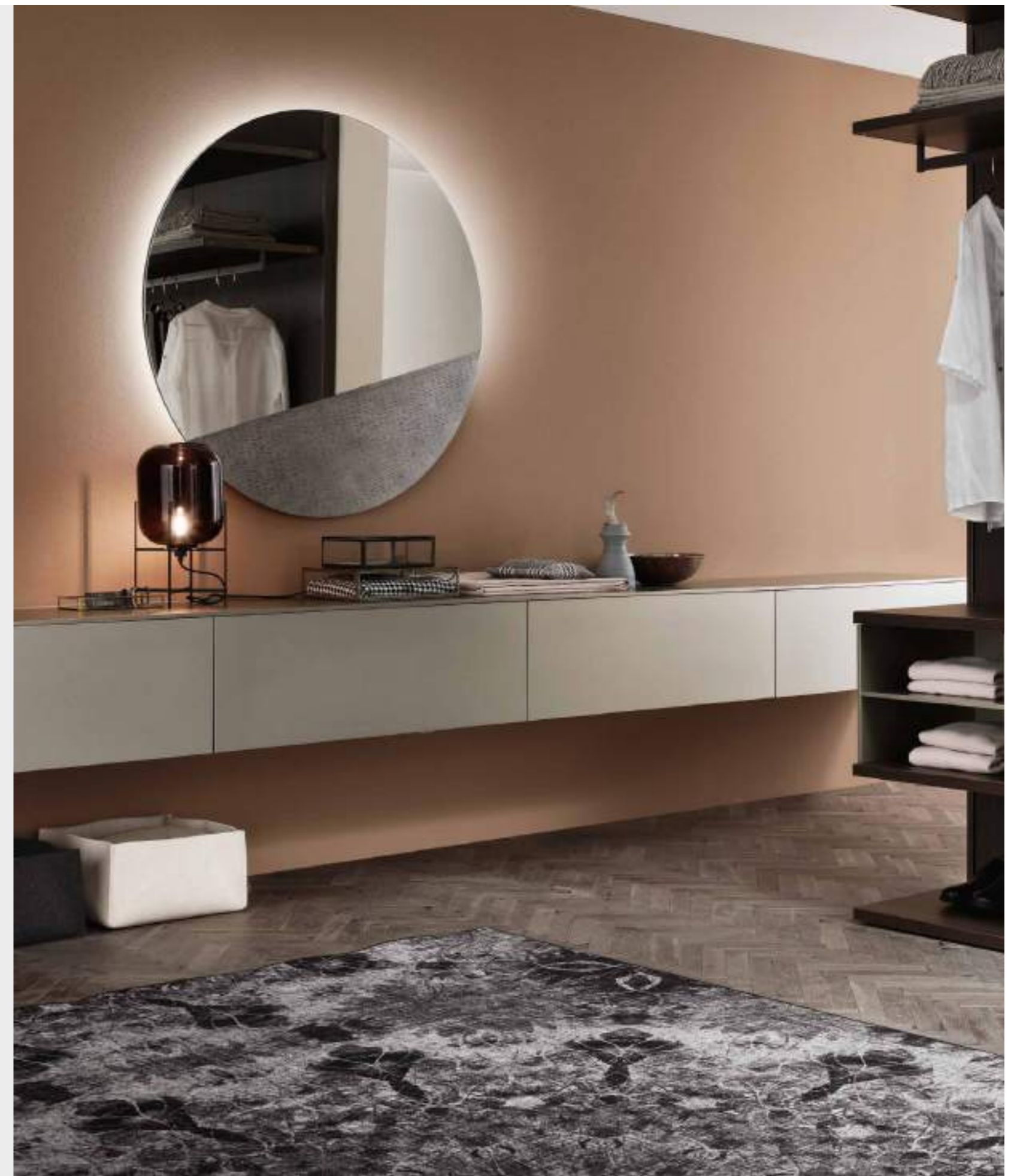
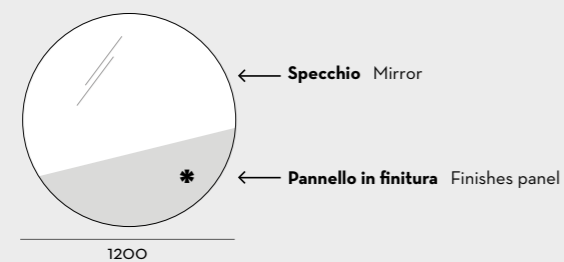

Mirrors **Sfera**

Trio di specchiere tonde

Trio of round mirrors
↑

IT Lo specchio tondo è disponibile in tre dimensioni, che possono essere mixate tra di loro per creare composizioni creative sulla parete. Una geometria perfetta per decorare qualsiasi ambiente.

EN The round mirrors are available in three sizes that can be mixed and matched to create decorative wall compositions. Perfect geometry for any room.

FINITURE finishes

Specchio Argento - Bronzo Silver - Bronze mirror

DIMENSIONI dimensions

Sp 22 mm

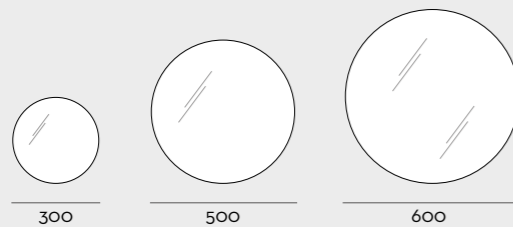

Mirror **Pato**

Specchiera rettangolare

Rectangular mirror
↑

IT La specchiera ha una cornice luminosa molto scenografica: può essere installata in verticale per una visione a figura intera oppure in orizzontale per dare più profondità allo spazio.

EN A stunning frame illuminates this mirror. It can be installed vertically to reflect an entire person or horizontally to add depth to the space.

FINITURE finishes

Melaminici (esclusi Calacatta - Ash Stone - Nero Marquina)
Melamine (Calacatta - Ash Stone - Nero Marquina excluding)

Laccati opachi in tutti i colori della mazzetta
Matt colour lacquered all the sample colours

Frassino colore laccato in tutti i colori della mazzetta
Colour lacquered ash all the sample colours

DIMENSIONI dimensions

Sp **80 mm**

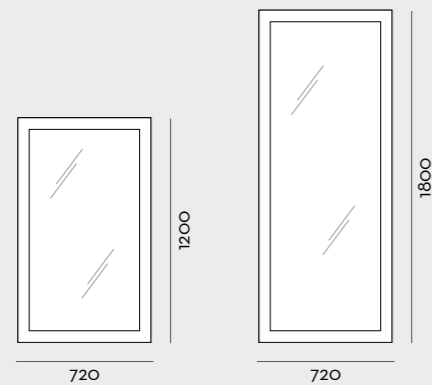

Bench **Club**

Panchetta

IT Un arredo versatile, che si presta a diventare un piano di appoggio originale. In una zona d'ingresso, in un angolo del living, in corridoio o in camera da letto: ovunque la panchetta è decorativa e funzionale.

EN This versatile piece can be used as an original support surface. Place it at the entrance, in a corner of the living room, in a hallway or a bedroom: any place where a bench is decorative and functional.

Bench ↑

SEDUTA seat

Rovere Vero - Grigio - Savana - Moka Vero - Grigio - Savana - Moka oak

STRUTTURA frame

Metallo Nero opaco Matt Black metal

DIMENSIONI dimensions

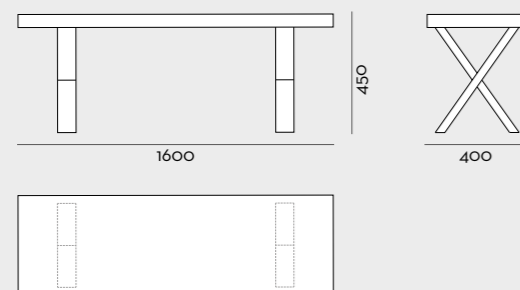

Bench **Tosca**

Panchetta

IT Un arredo solitamente usato all'esterno entra negli ambienti della casa per caratterizzarli con naturalezza e un tocco di originalità. La panchetta in legno può essere posizionata ovunque ci sia spazio e spostata con facilità.

EN Though usually found outdoors, once inside, it adds a natural touch of originality. This wooden bench can be placed wherever there is space and moved to wherever it is needed.

Bench ↑

STRUTTURA frame

Rovere Massiccio Vero - Grigio - Savana - Moka Vero - Grigio - Savana - Moka Solid Oak

DIMENSIONI dimensions

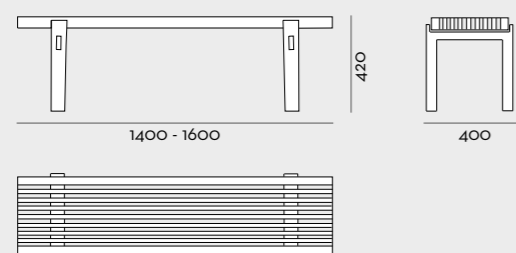

Light Discovery

Lampade a sospensione

IT La lampada a sospensione è caratterizzata da un disco personalizzabile con sei grafiche diverse, che possono essere abbinata anche alle carte da parati per un effetto coordinato tra luci e pareti.

EN This pendant light features a disc that can be personalised with six different designs, which can also be coordinated with wallpaper.

Pendant light ↑

SUPPORTO - PORTA LAMPADA support - light holder

Metallo verniciato Bianco - Nero White - Black painted metal

ANELLO ring

Grafica con abbinamento a colore Designs with matching colours

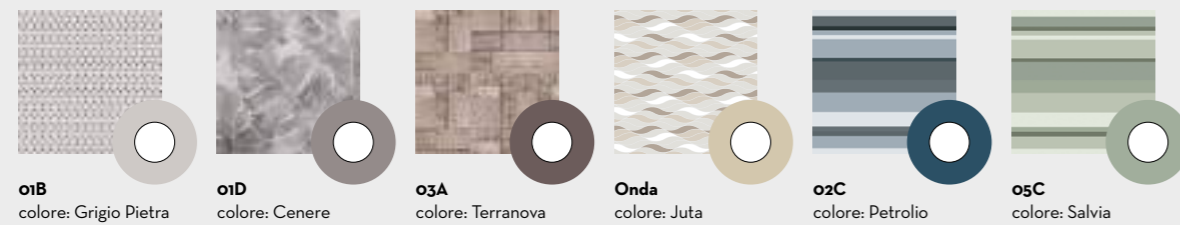

DIMENSIONI dimensions

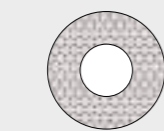
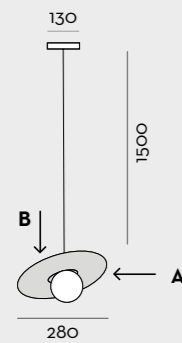

A 1 lato grafico
1 graphic side



B 1 lato colore in abbinata
1 color side matched



Light Origami

Lampade a sospensione

IT Il cilindro in vetro bianco dà forma a una lampada dal design essenziale e moderno. La luce è puntuale ed è adatta sopra a tavolini o comodini, ma le lampade possono essere disposte in linea per illuminare superfici più ampie.

EN A white glass cylinder gives shape to a light fitting that is minimal and modern. The light it offers is focused and ideal above coffee tables or bedside tables, or lined up in a row to illuminate larger surfaces.

Pendant light
↑

SUPPORTO support

Metallo verniciato Bianco White painted metal
Cavo in acciaio Steel cable

PARALUME lampshade

Vetro Bianco White glass

DIMENSIONI dimensions

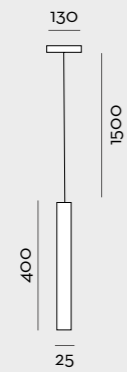

Light **Dion**

Lampade a sospensione

IT Una lampada dal gusto e dalle linee Seventies, perfetta sopra ad un tavolo moderno. Bianca per valorizzare uno stile minimal oppure bronzata per caratterizzare un ambiente di tendenza.

EN A light fitting with the Seventies on its mind, perfect above a modern table. White emphasises a minimalist style, whereas bronze is ideal for a current, on-trend setting.

Pendant light ↑

SUPPORTO support

Cavo in acciaio Steel cable

PARALUME lampshade

Interno ceramica Bianco White ceramic interior
Esterno lucido Bianco - Bronzo Glossy White - Bronze exterior

DIMENSIONI dimensions

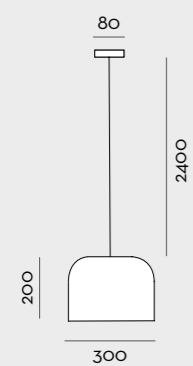

Light Emir

Lampade a sospensione

IT La sospensione è caratterizzata da un movimento di forme concentriche: un design originale per un contesto moderno. L'effetto scenografico è assicurato e raddoppia se le lampade sono in coppia.

EN This pendant light features an original concentric design that is perfect for modern settings. The stunning effect is twice as beguiling if these lights are paired.

Pendant light ↑

SUPPORTO support

Cavo in acciaio Steel cable

PARALUME lampshade

Tessuto Honey Comb colore Bianco - Nero Honey Comb fabric in White - Black colours

DIMENSIONI dimensions

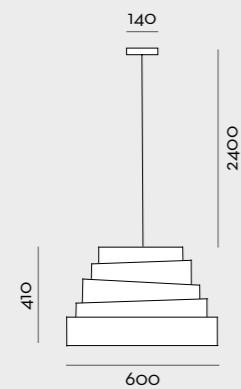

Light **Tudor**

Lampade a sospensione

IT Oltre a illuminare, nelle sue versioni metallizzate la lampada riflette la luce naturale e impreziosisce gli ambienti con la sua brillantezza. Ideale per decorare lo spazio e dare risalto a un angolo.

EN In addition to providing light, the metallic versions of this fitting reflect natural light and illuminate the setting. Ideal for decorating spaces and creating atmosphere in corners.

Pendant light
↑

SUPPORTO support

Cavo in acciaio Steel cable

PARALUME lampshade

Metallo Cromo - Rame - Ottone - Bianco lucido
Chrome - Copper - Brass - White glossy metal

DIMENSIONI dimensions

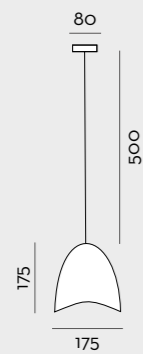

Light Lamp

Lampade a sospensione

IT La forma semplice del paralume è messa in risalto da una finitura speciale, la fibra di carbonio. La sospensione è perfetta per essere inserita in contesti moderni e ricercati, che puntano su materiali di pregio.

EN The simple design of this light shade is enhanced by a special carbon fibre finish. This pendant is perfect for modern, refined settings where materials are chosen with attention.

Pendant light ↑

SUPPORTO support

Cavo in acciaio Steel cable

PARALUME lampshade

Esterno fibra di carbonio Nero Black carbon fibre exterior
Interno verniciato colore Avorio Ivory painted interior

DIMENSIONI dimensions

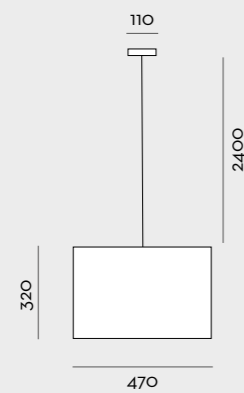

Light **Paint**

Lampade LED

IT Con il suo gioco di forme, la lampada dà luce alla parete e valorizza lo spazio come un quadro astratto. Può essere posizionata in verticale o in orizzontale per creare geometrie diverse e luminose.

EN The gorgeous abstract form of this wall lamp are wonderful addition to a living space. It can be positioned vertically or horizontally to create different luminous geometries.

Pendant light ↑

STRUTTURA frame

Metallo laccato Bronzo - Ottone - Nichel - Ferro - Nero - Bianco opaco
Matt Bronze - Brass - Nickel - Iron - Black - White lacquered metal

Box interruttore: Calacatta - Ash Stone - Nero Marquinia / Laccato Bronzo - Ottone - Nichel - Ferro - Nero - Bianco opaco
Switch box: Calacatta - Ash Stone - Nero Marquinia / Matt Bronze - Brass - Nickel - Iron - Black - White lacquered

DIMENSIONI dimensions

P 85 mm

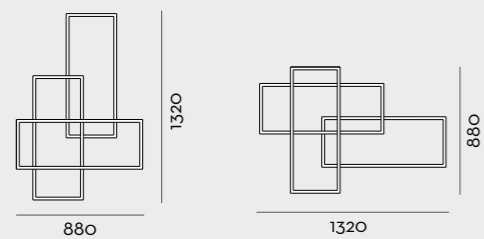

The Classics
↓

ARREDI
SENZA TEMPO,
PROTAGONISTI
DI AMBIENTI
ELEGANTI.

Timeless pieces, the focus of elegant spaces.

i Classici

Collezioni dal gusto classico
per arredare con stile la casa di oggi.
Collections with classic designs
to bring style to today's home.

index

- 399 → **Gardenia**
- 401 → **Iris**
- 403 → **Asolana**
- 405 → **Murano**

Classic **Gardenia**

Collezione classico

Classic collection
↑

IT Gardenia è una collezione che si affida alla tradizione per creare qualcosa di nuovo e originale: Un'eleganza concreta e attuale, dinamica e armonica, capace di mostrare il living sotto una nuova luce.

EN The Gardenia collection relies on tradition to create something new and original. Authentic, current elegance that is both dynamic and balanced, showing the living room in a new light.

FINITURE finishes

Frassino Ash

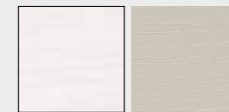

Bianco Juta

Frassino colore laccato in tutti i colori della mazzetta Colour lacquered ash all the sample colours

Serigrafie Serigraphs



Bianco Serigrafia 03B Juta Serigrafia 03B Canapa Serigrafia 03B Magma Serigrafia 03B



Bianco Serigrafia 04A Juta Serigrafia 04A Canapa Serigrafia 04A Magma Serigrafia 04A

GARDENIA catalogo - catalogue

Per consultare tutta la collezione [vedi catalogo Classico Gardenia](#)
See the Classico Gardenia catalogue **for all of the collection**



Frassino laccato / Lacquered ash
Grigio Pietra

Modia GA0004
L 2112 x P 495 x H 716 mm

Classic Iris

Collezione classico

Classic collection ↑

IT La perfezione delle forme, l'equilibrio delle proporzioni, la bellezza delle finiture e la cura dei particolari sono i caratteri distintivi di una zona giorno in cui tutti gli elementi sono in perfetta armonia tra di loro.

EN Perfect forms, balanced proportions, beautiful finishes and attention to detail are the distinctive features of a living area where all elements are in perfect harmony with each other.



FINITURE finishes

Olmo Elm

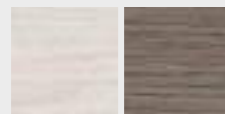

Artico Grigio

Frassino Ash

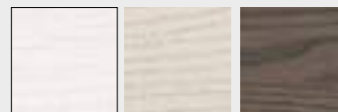

Bianco Argilla Caffè

IRIS catalogo - catalogue

Per consultare tutta la collezione [vedi catalogo Classico Iris](#)
See the Classico Iris catalogue [for all of the collection](#)



Frassino / Ash
Argilla

Tavolo Iride
L 1600 / 2150 x L 850 x H 748 mm

Classic Murano

Collezione classico

Classic collection ↑

IT Un living dove il tempo ritorna velocemente indietro a recuperare un particolare della memoria e vola in avanti ad inseguire una nuova idea. Un living dove lo stile trova l'eleganza nella sintesi di linee e volumi.

EN Living areas which look to the past reigniting specific memories to then leap into the future establishing novel ideas. A living area where style assumes elegance with the union of lines and volumes.



FINITURE finishes

Esenze Essence

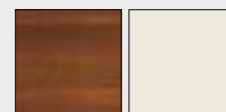

Noce Panna Invecchiato

MURANO catalogo - catalogue

Per consultare tutta la collezione [vedi catalogo Classico Murano](#)
See the [Classico Murano catalogue](#) **for all of the collection**



Essenza / Essence
Panna Invecchiato

Madia Murano
L 1898 x P 520 x H 824 mm

Classic **Asolana**

Collezione classico

IT La bellezza del noce, con la sua storia e il suo inimitabile calore. L'armonia della forma, ispirata alla genuina semplicità di una grande tradizione classica. Asolana è una perfetta sintesi di stile.

EN The beauty of the walnut, portraying its history and unmatched warmth. The balance of forms, drawing inspiration from the genuine simplicity of a great classic tradition. Asolana and style are perfectly synonymous.

Classic collection ↑



FINITURE finishes

Noce Walnut

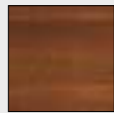

ASOLANA catalogo - catalogue

Per consultare tutta la collezione [vedi catalogo Classico Asolana](#)
See the [Classico Asolana catalogue](#) **for all of the collection**



Noce / Walnut

Tavolo Soave
L 1350 / 2150 x L 850 x H 796 mm

Wallpaper ↓

LE PARETI
PRENDONO
VITA E
CREANO
NUOVE
ATMOSFERE.

Walls come to life and create new atmospheres.

Wallpaper



01 Modern



01A



01B



01C



01D

02 Mix

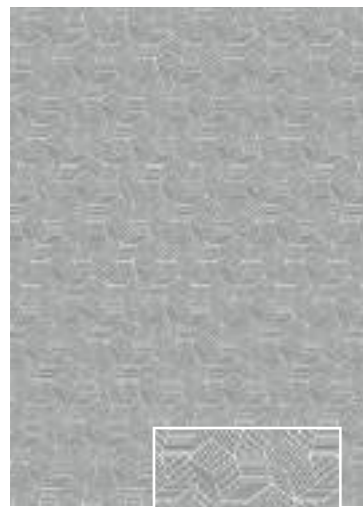

02A



02B

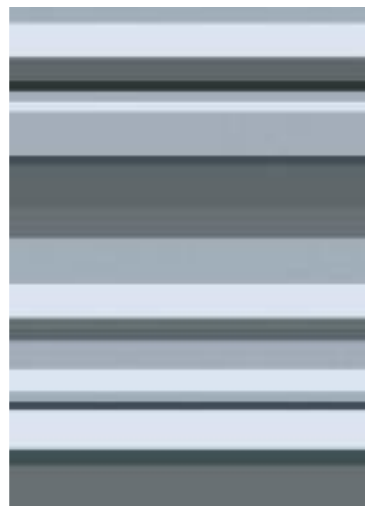

02C



02D

Cambio colore Change color



05A



05B



05C



05D

03 Texture



03A



03B



03C



03D

04 Elegance

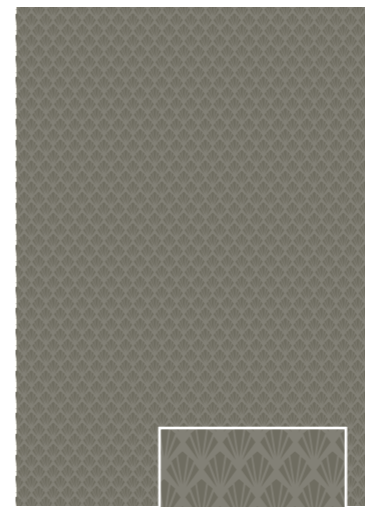

04A

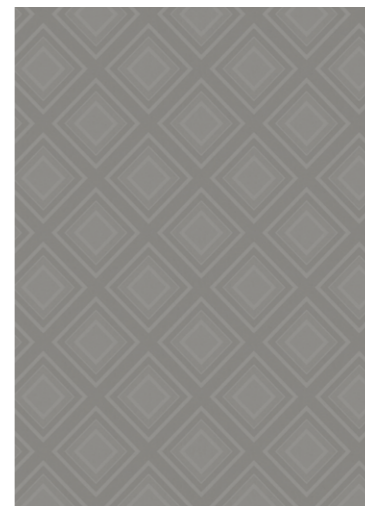

04B

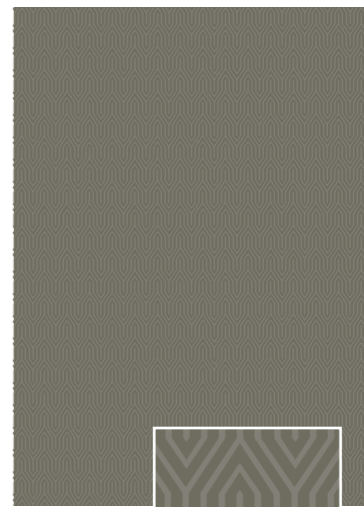

04C



04D

Wallpaper



Lettering

Affresco

Geometrici

Onda



Iride

Iride b/n

Marrakesh

Piume

Scegli il colore dalla mazzetta laccati "Maronese ACF"
 Choose the colour from the "Maronese ACF" lacquer fan-deck



Cuore

Rombi

Anni 50

Spina pesce



La carta da parati viene fornita in rotoli da L 600 mm, altezza massima disponibile H 3000 mm. Compresa di colla per il fissaggio alla parete.

The wallpaper is supplied in 600 mm wide rolls, maximum length 3000 mm. Provided with glue to apply it to the wall.

Handles / Finishes



DETTAGLI
E MATERIALI
VESTONO E
RIVESTONO
GLI ARREDI.

Details and materials add style and finish to furniture.

Maniglie Finiture

Tante possibilità di scelta per personalizzare i propri ambienti.
So many options for personalising a space.

[index](#)

414 → **Maniglie** handles

415 → **Finiture** finishes



Maniglie

Handles



Y128

C100

B100

Per consultare tutte le maniglie vedi Listino Complementi
See Complements price list for all of the handles collection



Melaminici essenza

Wood melamine



Olmo Artico

Olmo Grigio

Rovere Nodato

Rovere Avena

Rovere Thea



Frassino Bianco

Frassino Juta



Melaminici colore

Colour melamine



Bianco

Ghiaccio

Titanio

Grafite



Essenze

Wood



Rovere Vero

Rovere Grigio

Rovere Savana

Rovere Moka

Solo per complementi tavoli e sedie Only for tables and chairs complements



Frassino Vero

Frassino Grigio

Frassino Savana

Frassino Moka

Solo tavoli Cleo, Gelius, Planet, Taiga, Strong e Triade Only for Cleo, Gelius, Planet, Taiga, Strong and Triade tables

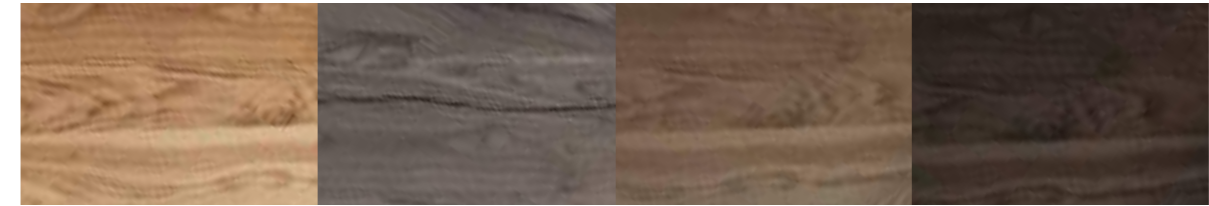

Frassino Olivato Massiccio Vero

Frassino Olivato Massiccio Grigio

Frassino Olivato Massiccio Savana

Frassino Olivato Massiccio Moka



Ceramica Gres

Stoneware

Solo tavolo Radius Only for Radius table



Pietra Grey

Pietra Statuario



Melaminici cemento

Cement melamine



Cemento



Melaminici marmo

Marble melamine



Calacatta

Ash Stone

Nero Marquinia



Frassino colore . Colori laccati lucidi e opachi . Vetro colore

Ash wood colours . Glossy and matt lacquered colours . Coloured glass



Bianco Ecrù Juta Canapa Terranova Brown Ghiaccio Grigio Pietra



Agata Titanio Cenere Magma Grafite Antracite Nero Verde Bosco



Iguana Verde Oliva Verde Palude Salvia The Verde Verde Acqua Celeste Nuvola



Ceruleo Navy Petrolio Giallo Polline Mattone Cotto Melograno Rosso Lips



Geranio Bordeaux Porpora Cipria Rosa Vintage Terra Castagno Bronzo

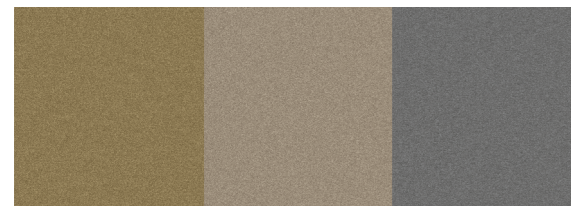

Ottone Nichel Ferro



Ecopelli

Eco-leathers



Bianco Grigio Chiaro Grigio Medio Grigio Scuro



Grigio Perla Sabbia Fango Tortora

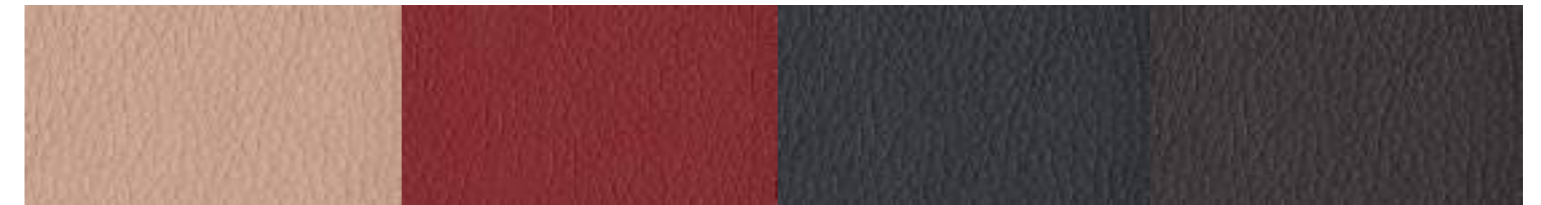

Rosa Bordeaux Blu Nero



Ecopelli Gold

Gold eco-leathers



Gold 01 Gold 02 Gold 03 Gold 04

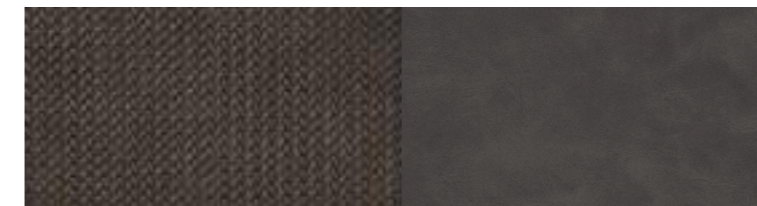

Gold 05 Gold 06



Tessuti Lino
Flax fabric



Planet 501 Planet 504 Planet 534 Planet 548 Planet 531



Planet 549 Planet 523 Planet 515 Planet 529 Planet 524



Planet 546 Planet 518



Tessuti
Fabric

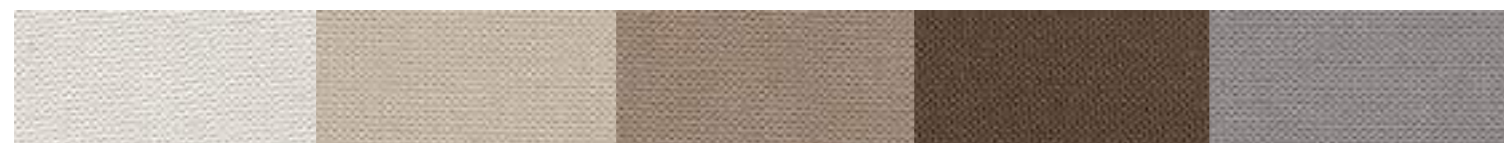

Point 01 Point 11 Point 14 Point 28 Point 06



Point 16 Point 05 Point 33 Point 18 Rally 602



Rally 601 Rally 600 Rally 403 Flirt Ecrù Flirt Cemento



Flirt Maron Glasè Flirt Arancio Bruciato Flirt Blue Jeans Flirt Grigio Lino



Finiture Decor
Decor finish

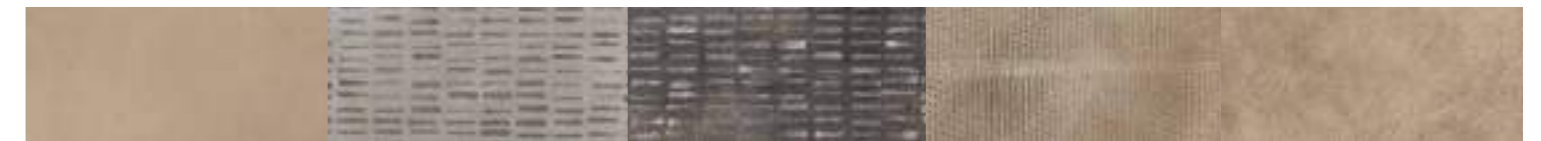

Decor Golden Decor Silver Decor Night Decor Magic Decor Soft



Decor Garden Decor Town Decor Wave



Stampe grafiche tavolini
Coffee tables prints with designs



01A 01B 01C 01D 02A 02B 02C



02D 05A 05B 05C 05D 03A 03B

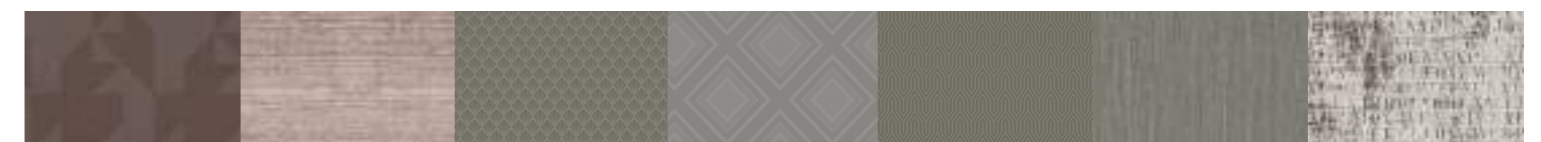

03C 03D 04A 04B 04C 04D Lettering



Affresco Geometrici Onda Cuore Rombi Anni 50 Spina pesce



Iride Iride b/n Marrakesh Piume

art direction & graphic design
Lokomotiv

photo
Indoor

styling
Rossi & Co

technical consulting
Loris Biasatti

colour separation
Luce

print
OGM

June 2020



www.gruppoatma.it

MARONESE ACF

MARONESE INTERNATIONAL SRL Via Taglio 60, 33070 Maron di Brugnera (PN) Italy T. +39 0434 623421 F. +39 0434 623695

info@maroneseacf.it www.maroneseacf.com