

—  
day collection  
*Modulo*



Indice  
index

# *Modulo*

MODULO 01	<i>8</i>	MODULO 06	<i>64</i>
MODULO 02	<i>20</i>	MODULO 07	<i>78</i>
MODULO 03	<i>30</i>	MODULO 08	<i>90</i>
MODULO 04	<i>42</i>	MODULO 09	<i>102</i>
MODULO 05	<i>54</i>	MODULO 10	<i>110</i>

# *Creatività Innovazione Esperienza*

CREATIVITY INNOVATION  
EXPERIENCE



## L'INNOVAZIONE: COME LA RIUSCITA ATTUAZIONE DI IDEE.

*I processi creativi quali sinonimo di una visuale più ampia capace di orientare il nostro compito; fondere la bellezza con la versatilità e la comodità figlie del nostro tempo. L'azienda nasce nella prima metà degli anni sessanta, seguendo una gestione "familiare", il brand Veneran, forte dei primi successi, cresce ed evolve, conquistando un ruolo ed una fetta di mercato sempre più consistente a livello nazionale ed internazionale, comparando come inserzionista nelle più importanti riviste d'arredamento italiane. L'obiettivo e la nostra filosofia è di sfidare ogni mercato, ponendo l'accento su quella che oggi è moda chiamare "new economy", senza trascurare i tradizionali sistemi di vendita e distribuzione.*

*La produzione spazia dalla zona notte alla zona giorno, passando per l'armadio, le cabine ed i gruppi letto, concentrando i propri sforzi nell'evoluzione tecnologica e nella manualità, da sempre biglietto da visita e punto di forza dell'azienda.*

*Materiali all'avanguardia, finiture di pregio e una costante ricerca progettuale hanno reso le industrie Veneran protagoniste di livello in uno scenario sempre più concorrenziale e di tendenza, all'insegna del dinamismo totale.*

## INNOVATION: THE SUCCESSFUL IMPLEMENTATION OF IDEAS.

In our opinion, creative processes are synonymous of a broader point of view capable of directing our task, i.e. to blend beauty with the versatility and comfort that are fruits of our times. We founded Veneran in the first half of the seventies as a family-run business. Based on its initial success, the brand grew and evolved, conquering an increasingly more significant role and larger market segments in Italy and abroad while advertising in the most important Italian furniture magazines. Without neglecting traditional sales and distribution systems, our goal and philosophy is to challenge all markets by focusing on what is nowadays called the new economy. Our production ranges cover both night and day areas and include wardrobes, walk-in-wardrobes and bedroom furniture. Our company's efforts focus on advanced technology combined with handcraft expertise, both of which have always been our strong suit and the best way of introducing ourselves. Cutting-edge materials, precious finishes and ongoing research into design distinguish our industries, ranking us as top players in an increasingly more competitive and trendy market that is directed towards total dynamism.



Collezione  
collection

# Modulo

## NUOVE INTERPRETAZIONI DI FORMA E STILE

*Con Modulo di Veneran la zona living viene totalmente rivoluzionata negli spazi e nello stile. Un progetto modulare che vede interessata non solo la zona home entertainment ma anche tutte le aree che gravitano intorno ad essa: madie, librerie, angolo studio e piccoli complementi come console e mobiletti da affiancare all'angolo divano. Un progetto quindi a 360° che riorganizza con eleganza l'area più utilizzata della casa, uno spazio concepito come un grande openspace unificato nell'immagine e nello stile.*

## NEW INTERPRETATION OF THE SHAPE AND STYLE

With the collection Modulo by Veneran the living area is totally renew in the room and in the style. A modulo project which involves not only the home entertainment area but also all the remaining areas spinning around it: cupboards, bookshelves, a office corner and some small items like consoles and small pieces of furniture to approach the corner sofa. A 360° project which reorganizes with elegance the most lived space of the house, a space studied as a big open space unified by the look and style.

veneran

Collezione  
collection

# *Modulo*

*L'essenza dei luoghi è data dalla  
personalità con cui li arrediamo.*

THE ESSENCE OF THE ROOMS IS  
GIVING BY THE PERSONALITY OF THE  
FURNISHING STYLE.

*01*









L. 361 H. 171 (199,5 DA TERRA) P. 45/38 - SCOCHE E FRONTALI PENSILI: TALPA LACCATO OPACO - MENSOLE: TALPA LACCATO OPACO - SCOCHE VETRINE PENSILI: ROVERE TERMOCOTTO - FRONTALI VETRINE PENSILI: ALLUMINIO ANTRACITE E VETRO TRASPARENTE BRONZO - BOISERIE: ROVERE TERMOCOTTO.

W. 361 H 171 (199,5 FROM FLOOR) D. 45/38 - CASE AND FRONT OF THE HANGING UNITS: TALPA MAT LACQUER - SHELVING: TALPA MAT LACQUER - CASE OF THE HANGING GLASS CABINETS: ROVERE TERMOCOTTO - FRONT OF THE HANGING GLASS CABINETS: ALLUMINUM ANTRACITE AND BRONZE TRANSPARENT GLASS - PANNELLING: ROVERE TERMOCOTTO.



*Soluzioni d'arredo pensate per garantire la massima flessibilità: contenitori a terra o sospesi, con cassetti, ante battenti, ribalte o vasistas.*

Furnishing solutions thought to guarantee the maximum flexibility: floor and hanging units, with drawers, hinged doors, flap up or down.







L. 228 H. 19 P. 28/19 - SCOCHE E FRONTALI PENSILI: ROVERE TERMOCOTTO - ELEMENTI GIORNO: METALGREY.

W. 228 H. 19 D. 28/19 - CASE AND FRONT OF THE HANGING UNITS: ROVERE TERMOCOTTO - OPEN UNITS: METALGREY.



L. 228 H. 61 P. 38 - SCOCHE E FRONTALI BASI E PENSILE: ROVERE TERMOCOTTO - ELEMENTO VASSOIO E DISTANZIALE: TALPA LACCATO OPACO.

W. 228 H. 61 D. 38 - CASE AND FRONT OF THE FLOOR AND HANGING ITEMS: ROVERE TERMOCOTTO - TRAY UNIT AND SPACER: TALPA MAT LACQUER.



*Basi a terra o sospese, prevedono moduli in misure illimitate così da garantire soluzioni adeguate ad ogni esigenza di spazi e dimensioni.*

Floor or hanging units are studied in order to offer a never ending choice on dimension suitable for any space or dimension available.



L. 437 H. 173 P. 45 - FRONTALE MADIA: ROVERE TERMOCOTTO, TALPA LACCATO OPACO - SCOCCA MADIA: ROVERE TERMOCOTTO, TALPA LACCATO OPACO - ELEMENTO A GIORNO: TALPA LACCATO OPACO.

W. 437 H. 173 D. 45 - CUPBOARD FRONT: ROVERE TERMOCOTTO, TALPA MAT LACQUER - CUPBOARD CASE: ROVERE TERMOCOTTO, TALPA MAT LACQUER - OPEN UNIT: TALPA MAT LACQUER.

Collezione  
collection

# *Modulo*

*Casa è dove conosci gli spazi  
abbastanza bene da riuscire a  
orientarti anche al buio.*

HOME IS WHERE YOU KNOW THE  
ROOM QUITE ENOUGH TO GET  
ORIENTED EVEN IN THE DARK.

*02*









L. 399 H. 152 (190 DA TERRA) P. 38 - SCOCHE E FRONTALI PENSILI: ROVERE TERMOCOTTO - MENSOLA: ROVERE TERMOCOTTO - SCOCHE VETRINE PENSILI: ROVERE TERMOCOTTO, SCHIENE CENERE LACCATO OPACO - FRONTALI VETRINE PENSILI: ALLUMINIO ANTRACITE E VETRO TRASPARENTE BRONZO - BOISERIE: ROVERE TERMOCOTTO.

W. 399 H. 152 (190 FROM FLOOR) D. 38 - CASE AND FRONT OF THE HANGING UNITS: ROVERE TERMOCOTTO - SHELVING: ROVERE TERMOCOTTO - CASE OF THE HANGING GLASS CABINETS: ROVERE TERMOCOTTO, BACKBOARDS CENERE MAT LACQUER - FRONT OF THE HANGING GLASS CABINETS: ALUMINUM ANTRACITE AND BRONZE TRANSPARENT GLASS - PANELLING: ROVERE TERMOCOTTO.





L. 228 H. 160 P. 45/26 - FRONTALE PENSILI: CENERE LACCATO OPACO - SCOCCA PENSILI: CENERE LACCATO OPACO - SCRITTOIO: CENERE LACCATO OPACO - ELEMENTI A GIORNO: CENERE LACCATO OPACO.

W. 228 H. 160 D 45/26 - FRONT OF THE HANGING UNIT: CENERE MAT LACQUER - CASE OF THE HANGING UNITS: CENERE MAT LACQUER - DESK: CENERE MAT LACQUER - OPEN UNITS: CENERE MAT LACQUER





L. 152 H. 40 P. 38 - FRONTALI: ROVERE TERMOCOTTO - SCOC-  
CA: ROVERE TERMOCOTTO - ELEMENTI VASSOIO: ROVERE  
TERMOCOTTO.

W. 152 H. 40 P. 38 - FRONT: ROVERE TERMOCOTTO - CASE:  
ROVERE TERMOCOTTO - TRAY ITEM: ROVERE TERMOCOTTO.



Collezione  
collection

# *Modulo*

*La casa è il luogo dove  
vengono creati i ricordi.*

HOME IS WHERE THE PEOPLE  
CREATE MEMORIES.

*03*









L. 437 H. 152 (180,5 DA TERRA) P. 45/38 - FRONTALE PENSILI: FRASSINO NATURALE, FANGO LACCATO OPACO - SCOCCHA PENSILI: FRASSINO NATURALE, FANGO LACCATO OPACO - MENSOLE: FANGO LACCATO OPACO - SCOCHE VETRINE PENSILI: FRASSINO OSSIDATO NATURAL - FRONTALI VETRINE PENSILI: ALLUMINIO ANTRACITE E VETRO TRASPARENTE BRONZO - BOISERIE: FANGO LACCATO OPACO.

W. 437 H. 152 (180,5 FROM FLOOR) P. 45/38 - FRONT OF THE HANGING UNITS: FRASSINO NATURALE, FANGO MAT LACQUER - CASE OF THE HANGING UNITS: FRASSINO NATURALE, FANGO MAT LACQUER - SHELVING: FANGO MAT LACQUER - CASE OF THE HANGING GLASS CABINETS: FRASSINO OSSIDATO NATURAL - FRONT OF THE HANGING GLASS CABINETS: ALLUMINUM ANTRACITE AND BRONZE TRANSPARENT GLASS - PANNELLING: FANGO MAT LACQUER.

*Anche l'home entertainment trova la giusta dimensione attraverso le pannellature attrezzabili con contenitori, ripiani, moduli a giorno e vani libreria.*

Also the home entertainment finds the right dimension through the panelling which can be equipped with containers, shelves, open units and bookshelf units.







MADIA CLOE L.122 H.146 P.50 - FRONTALI: VETRO LUCIDO  
CARRARA - SCOCCA: FRASSINO OSSIDATO NATURAL.

SIDEBBOARD CLOE W. 122 H. 146 D. 50 - FRONT: HIGH GLOSS  
CLASS CARRARA - CASE: FRASSINO OSSIDATONATURAL.





L. 304 H. 114 (171 DA TERRA) P. 45/38 - FRONTALE PENSILI: FRASSINO OSSIDATO NATURAL - SCOCCA PENSILI: FRASSINO OSSIDATO NATURAL - ELEMENTI A GIORNO: FANGO LACCATO OPACO - FRONTALI VETRINE PENSILI: ALLUMINIO ANTRACITE E VETRO TRASPARENTE BRONZO.

W. 304 H 114 (171 FROM FLOOR) D. 45/38 - FRONT OF THE HANGING UNITS: FRASSINO OSSIDATO NATURAL - CASE OF THE HANGING UNITS: FRASSINO OSSIDATO NATURAL - OPEN UNITS: FANGO MAT LACQUER - FRONT OF THE HANGING GLASS CABINETS: ALLUMINUM ANTRACITE AND BRONZE TRANSPARENT GLASS.



Collezione  
collection

# *Modulo*

*Gran parte del carattere di  
ogni individuo può essere letto  
nella sua casa.*

A BIG PART OF THE CHARACTER OF A  
PERSON IS EXPRESSED BY HIS HOUSE.

JOHN RUSKIN

*04*









L. 418 H. 192 P. 45/38/19 - SCOCHE E FRONTALI BASI, PENSI-  
LI E COLONNA GIORNO: FUMO E CENERE LACCATO OPACO  
- SCOCHE VETRINE: FUMO LACCATO OPACO - FRONTALI  
VETRINE: ALLUMINIO ANTRACITE E VETRO TRASPARENTE  
BRONZO - BOISERIE: FUMO LACCATO OPACO - ELEMENTI  
METALLO: METALGREY OPACO, SCHIENE CENERE LACCATO  
OPACO.

W. 481 H. 192 P. 45/38/19 - CASE AND FRONT OF THE FLO-  
OR, HANGING AND OPEN UNITS: FUMO AND CENERE MAT  
LACQUER - CASE OF THE GLASS CABINETS: FUMO MAT LAC-  
QUER - FRONT OF THE GLASS CABINETS: ALLUMINIUM AN-  
TRACITE AND BRONZE TRANSPARENT GLASS - PANNELLING:  
FUMO MAT LACQUER - METAL ITEM: MAT METALGREY,  
BACKBOARDS CENERE MAT LACQUER.



*In Modulo non c'è elemento d'arredo che non possa essere utilizzato in modo creativo e personalizzato. Anche due semplici pensili possono fondersi in un unico elemento scultoreo grazie ai "quadrotti" in metallo di varie dimensioni.*

In the Modulo collection all items can be used in a creative and custom way. Even two simple hanging units can combine in a statue shaped item thanks to the metal square shaped items available in different dimensions.







L. 380 H. 114 (171 DA TERRA) P. 38 - FRONTALE PENSILI: FUMO LACCATO OPACO - SCOCCA PENSILI: FUMO LACCATO OPACO, CENERE LACCATO OPACO - FRONTALI VETRINE: ALLUMINIO ANTRACITE VETRO TRASPARENTE BRONZO - ELEMENTI A GIORNO: CENERE LACCATO OPACO.

W. 380 H. 114 (171 FROM THE FLOOR) P. 38 - FRONT OF THE HANGING UNITS: FUMO MAT LACQUER - CASE OF THE HANGING UNITS: FUMO MAT LACQUER, CENERE MAT LACQUER - FRONT OF THE GLASS CABINET: ALLUMINUM ANTRACITE, BRONZE TRANSPARENT GLASS - OPEN UNITS: CENERE MAT LACQUER.



MADIA CLOE L. 122 H. 146 P. 50 - FRONTALI: CENERE LACCATO OPACO - SCOCCA: FUMO LACCATO OPACO.

MADIA CLOE L. 122 H. 146 P. 50 - FRONT: CENERE MAT LACQUER - CASE: FUMO MAT LACQUER





Collezione  
collection

# *Modulo*

*Ci vogliono le mani per costruire  
una abitazione, ma solo il cuore  
può costruire una casa.*

TO BUILD A HOUSE YOU NEED THE  
HANDS, BUT TO CREATE A HOME YOU  
NEED THE HEART.

*05*









*Ante battenti laccate opaco dello spessore di 2 cm con apertura a gola. Vano libreria che sfrutta la profondità del fianco e base sospesa in finitura legno con scocca con taglio a 45 gradi.*

*Vetrina con ante in vetro trasparente bronzo con luce integrata nel fianco e boiserie con pannellature in essenza chiara. Ogni elemento sottolinea l'importanza e il valore attribuito alla cura dei dettagli nell'intero programma Modulo giorno.*

Hinged door mat lacquer in the thickness of 2 cm with gola opening. Bookshelf unit which uses the depth of the side panel and hanging unit in wood finishing with 45° cut. Glass cabinet with bronze transparent glass doors with built-in lighting on the side panel and panelling in clear finishing. Each item underlines the importance and the value given to the care of the details in the whole Modulo program.





L. 475 H. 192 P. 45/38 - SCOCHE E FRONTALI BASI: CORDA LACCATO OPACO - SCOCHE VETRINE BASI: FRASSINO OSSIDATO GREY - FRONTALI VETRINE BASI: ALLUMINIO ANTRACITE E VETRO TRASPARENTE BRONZO - SCOCHE E FRONTALI PENSILI ORIZZONTALI: FRASSINO OSSIDATO GREY - BOISERIE: FRASSINO OSSIDATO GREY.

W. 475 H. 192 P. 45/38 - CASE AND FRONT OF THE FLOOR ITEMS: CORDA MAT LACQUER - CASE OF THE FLOOR GLASS CABINETS: FRASSINO OSSIDATO GREY - FLOOR GLASS CABINETS: ALLUMINUM ANTRACITE AND BRONZE TRANSPARENT GLASS - CASE AND FRONT OF THE HORIZONTAL HANGING UNITS: FRASSINO OSSIDATO GREY - PANELLING: FRASSINO OSSIDATO GREY.





MADIA CLOE L. 236 H. 86 P. 50 - FRONTALI: VETRO LUCIDO CARRARA - SCOCCA: FRASSINO OSSIDATO GREY.

SIDEBOARD CLOE W. 236 H. 86 D. 50 - FRONT: HIGH GLOSS CLASS CARRARA - CASE: FRASSINO OSSIDATO GREY.



Collezione  
collection

# Modulo

*“La luce è ciò che vi guida a casa,  
il calore è quello che vi tiene lì.”*

“LIGHT IS WHAT LEADS YOU HOME,  
WARM IS WHAT KEEPS YOU THERE”

ELLIE RODRIGUEZ

06









L. 361 H. 230 P. 45/38 - SCOCHE E FRONTALI PENSILI ORIZZONTALI E PENSILI COLONNA: SPAGO LACCATO OPACO - SCOCCA VETRINA PENSILE: ASFALTO LACCATO OPACO - FRONTALI VETRINE PENSILE: ALLUMINIO ANTRACITE E VETRO TRASPARENTE BRONZO - ELEMENTO A GIORNO: FRASSINO OSSIDATO NATURALE.

W. 361 H. 230 D. 45/38 - CASE AND FRONT OF THE HORIZONTAL HANGING UNITS AND VERTICAL UNITS: SPAGO MAT LACQUER - CASE GLASS HANGING CABINETS: ASFALTO MAT LACQUER - FRONT OF THE GLASS HANGING CABINETS: ALLUMINIUM ANTRACITE AND BRONZE TRANSPARENT GLASS - OPEN UNITS: FRASSINO OSSIDATO NATURAL.



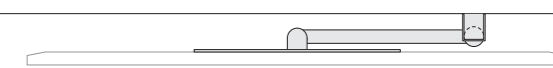
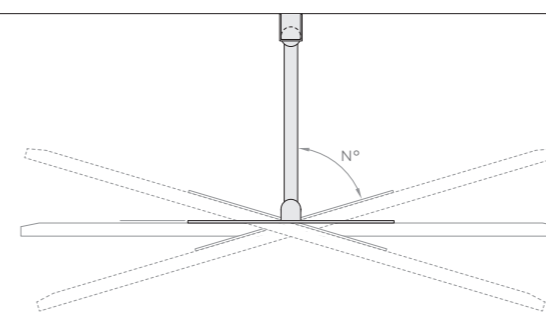
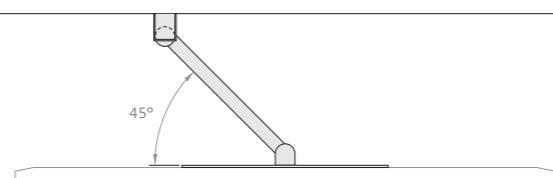
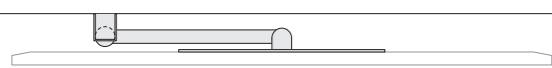
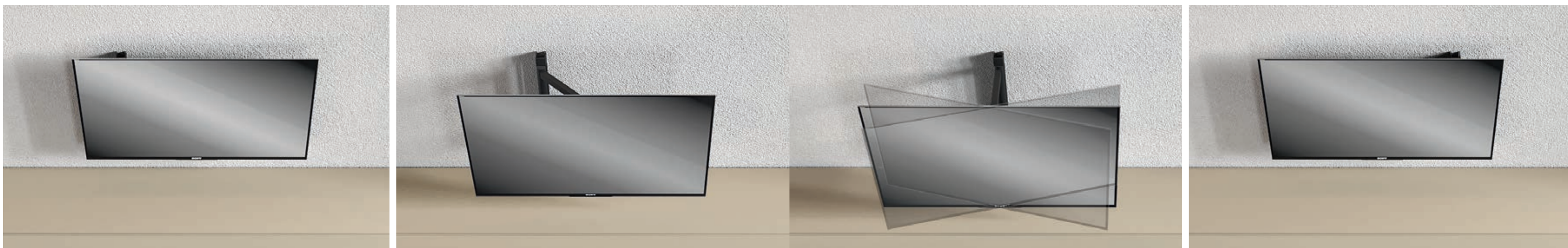

*Staffa porta Tv con braccetto estensibile  
per un maggiore distacco dalla parete  
e orientabile (raggio d'azione di 180°).*

TV rack with extensible arm for a bigger  
separation from the wall and pivoting  
(action ray 180°).



L. 342 H. 234 P. 38 - SCOCHE E FRONTALI BASI E PENSILI ORIZZONTALI: SPAGO LACCATO OPACO - SCOCHE VETRINE PENSILI: FRASSINO OSSIDATO NATURALE - FRONTALI VETRINE PENSILI: ALLUMINIO ANTRACITE E VETRO TRASPARENTE BRONZO - ELEMENTI A GIORNO: SPAGO LACCATO OPACO.

W. 342 H. 234 D. 38 - CASE AND FRONT OF THE FLOOR AND HORIZONTAL HANGING UNITS: SPAGO MAT LACQUER - CASE OF THE GLASS HANGING CABINETS: FRASSINO OSSIDATO NATURALE - FRONT OF THE GLASS HANGING CABINETS: ALUMINUM ANTRACITE AND BRONZE TRANSPARENT GLASS - OPEN UNITS: SPAGO MAT LACQUER.







*L'intersezione dei volumi dato dalla struttura in legno con la tridimensionalità delle ante, rende questa madia estremamente moderna.*

The intersection of the volumes given by the wooden structure with the 3-dimensionality of the doors, gives this cupboard an extremely modern aspect.



MADIA MODULAR L. 240 H. 75 P. 45,5 - FRONTALI E SCOC-  
CHE ELEMENTI: SPAGO LACCATO OPACO - SCOCCA MADIA:  
FRASSINO OSSIDATO GREY. CUPBOARD MODULAR W. 240 H. 75 P. 45,5 - FRONT AND  
CASE OF THE ITEMS: SPAGO MAT LACQUER - CASE OF THE  
CUPBOARD: FRASSINO OSSIDATO GREY.



Collezione  
collection

# Modulo

*“Un uomo percorre il mondo intero in cerca di ciò che gli serve e torna a casa per trovarlo.”*

"A MAN GOES AROUND THE WORLD SEARCHING FOR WHAT HE NEEDS AND HE FINDS IT AT HOME".

GEORGE AUGUSTUS MOORE

*07*









*La boiserie combinata a pensili con vani a giorno, rende possibile la creazione di diversi sviluppi compositivi.*

The panelling combined with open hanging units, makes possible different combining solutions.



L. 380 H. 182,5 P. 53/38 - SCOCHE E FRONTALI BASI ORRIZONTALI E PENSILI COLONNA: ANTRACITE LACCATO OPACO - SCOCCA TERMINALI GIORNO E BASE A VASSOIO: ECRÙ LACCATO OPACO - BOISERIE: ANTRACITE LACCATO OPACO.

W. 380 H. 182,5 D.53/38 - CASE AND FRONT OF THE HORIZONTAL FLOOR UNITS AND VERTICAL HANGING UNITS: ANTRACITE MAT LACQUER - CASE OF THE OPEN TERMINAL AND FLOOR TRAY UNITS: ECRU' MAT LACQUER - PANELING: ANTRACITE MAT LACQUER.







L. 247 H. 158 P. 38/19 - FRONTALI PENSILI: ECRÙ LACCATO OPACO - SCOCHE PENSILI: ECRÙ LACCATO OPACO E ANTRACITE LACCATO OPACO - ELEMENTI METALLO: METAL-GREY OPACO.

W. 247 H. 158 D. 38/19 - FRONT OF THE HANGING UNITS: ECRÙ MAT LACQUER - CASE OF THE HANGING UNITS: ECRÙ MAT LACQUER AND ANTRACITE MAT LACQUER - METAL ITEMS: MAT METALGREY.

*La madia è un contenitore trasversale a tutti gli ambienti, viene proposta con i frontali in laccato, essenza e vetro. Si caratterizza per la maniglia con presa a gola e i piedini in metallo.*

The sideboard is a storage unit useful for any space and it is suggested with the front in mat lacquer, wood and glass. It is characterized by the peculiar handle and the metal feet.

MADIA MODULAR L. 118 H. 136 P. 45,5 - FRONTALI: VETRO LUCIDO CALACATTA - SCOCHE ELEMENTI E MADIA: ANTRACITE LACCATO OPACO. SIDEBOARD MODULAR W. 118 H. 136 D. 45,5 - FRONT: HIGH GLOSS GLASS CALACATTA - UNIT CASE AND SIDEBOARD: ANTRACITE MAT LACQUER.



Collezione  
collection

# Modulo

*“Gli esseri umani, come le case,  
al di là della facciata nascondono  
un’anima interna.”*

"HUMAN BEINGS, LIKE HOUSES,  
BEHIND THE FRONT HAVE A INNER  
SOUL".

08







L. 608 H. 152 (171 DA TERRA) P. 45/38 - FRONTALE PENSILI: RESINA CEMENTO - SCOCHE PENSILI: FANGO LACCATO OPACO - SCOCHE VETRINE PENSILI: FRASSINO OSSIDATO NATURAL - FRONTALI VETRINE PENSILI: ALLUMINIO ANTRACITE VETRO TRASPARENTE FUMÉ - ELEMENTO A GIORNO: FANGO LACCATO OPACO - BOISERIE: RESINA CEMENTO.

W. 608 H. 152 (171 FROM FLOOR) D. 45/38 - FRONT OF THE HANGING UNITS: RESINA CEMENTO - CASE OF THE HANGING UNITS: FANGO MAT LACQUER - CASE OF THE HANGING GLASS CABINETS: FRASSINO OSSIDATO NATURAL - FRONT HANGING GLASS CABINETS: ALLUMINIUM ANTRACITE FUMÉ TRANSPARENT GLASS - OPEN UNITS: FANGO MAT LACQUER - PANNELLING: RESINA CEMENTO.









L. 228 H. 114 (171 DA TERRA) P. 45/38 - SCOCHE E FRONTALI PENSILI: CENERE LACCATO OPACO - SCOCHE VETRINE PENSILI: FANGO LACCATO OPACO - FRONTALI VETRINE PENSILI: ALLUMINIO ANTRACITE E VETRO TRASPARENTE BRONZO - ELEMENTI A GIORNO: FANGO LACCATO OPACO.

W. 228 H. 114 (171 FROM THE FLOOR) P. 45/38 - CASE AND FRONT OF THE HANGING UNITS: CENERE MAT LACQUER - CASE OF THE HANGING GLASS CABINETS: FANGO MAT LACQUER - FRONT HANGING GLASS CABINETS: ALLUMINUM ANTRACITE AND BRONZE TRANSPARENT GLASS - OPEN UNITS: FANGO MAT LACQUER.





L. 285 H. 96 P. 38/19 - ELEMENTI GIORNO: ANTRACITE LACCATO OPACO - ELEMENTI METALLO: METALGREY OPACO - MENSOLONE: FRASSINO OSSIDATO NATURAL.

W. 285 H. 96 P. 38/19 - OPEN UNITS: ANTRACITE MAT LACQUER - METAL UNITS: MAT METALGREY - BIG SHELF: FRASSINO OSSIDATO NATURAL.



Collezione  
collection

# *Modulo*

*“La casa è l’epidermide del corpo umano.”*

“HOME IS THE SKIN OF THE HUMAN BODY.”

FREDERICK KIESLER

*09*









L. 418 H. 133 (171 DA TERRA) P. 45/38/28 - FRONTALE E SCOC-  
CHE PENSILI ORIZZONTALI: CENERE LACCATO OPACO -  
SCOCHE VETRINE PENSILI E VASSOIO PENSILE: FRASSINO  
OSSIDATO BROWN - FRONTALI VETRINE PENSILI: ALLUMI-  
NIO ANTRACITE E VETRO TRASPARENTE BRONZO - **BOISERIE:**  
FRASSINO OSSIDATO BROWN E CENERE LACCATO OPACO -  
**MENSOLE:** VETRO TRASPARENTE BRONZO.

W. 418 H. 133 (171 FROM FLOOR) D. 45/38/28 - FRONT AND  
CASE HORIZONTAL HANGING UNITS: CENERE MAT LACQUER  
- CASE HANGING GLASS CABINETS AND HANGING TRAY: FRAS-  
SINO OSSIDATO BROWN - FRONT HANGING GLASS CABINETS:  
ALLUMINIUM ANTRACITE AND BRONZE TRANSPARENT GLASS -  
**PANELLING:** FRASSINO OSSIDATO BROWN AND CENERA MAT  
LACQUER - **SHELVING:** BRONZE TRANSPARENT GLASS.



L. 228 H. 80 P. 45,5 - FRONTALI E SCOCHE ELEMENTI: CENERE LACCATO OPACO - ZOCCOLI E DISTANZIALI: MOKA LACCATO OPACO.

W. 228 H. 80 D. 45,5 - FRONT AND CASE UNITS: CENERE MAT LACQUER - PLINTH AND SPACERS: MOKA MAT LACQUER.



Collezione  
collection

# *Modulo*

*“Le case sono fatte per viverci,  
non per essere guardate.”*

“HOUSES ARE BUILT TO LIVE IN,  
NOT TO WATCH ON”.

FRANCIS BACON

*10*









L. 475 H. 152 (171 DA TERRA) P. 45/38 - FRONTALE PENSILI: FUMO LACCATO OPACO - SCOCCA PENSILI: FUMO LACCATO OPACO - MENSOLE: FUMO LACCATO OPACO - BOISERIE: CENERE LACCATO OPACO. W. 475 H. 152 (171 FROM FLOOR) D. 45/38 - FRONT UNITS: FUMO MAT LACQUER - CASE HANGING UNITS: FUMO MAT LACQUER - SHELVING: FUMO MAT LACQUER - PANELLING: CENERE MAT LACQUER.





MADIA MODULAR L. 240 H. 75 P. 45,5 - FRONTALI E SCOC-  
CHE ELEMENTI: CENERE LACCATO OPACO - SCOCCA MADIA:  
FUMO LACCATO OPACO.

CUPBOARD MODULAR W. 240 H. 75 D. 45,5 - FRONT AND  
CASE UNITS: CENERA MAT LACQUER - CASE SIDEBOARD:  
FUMO MAT LACQUER.



Collezione  
collection

# Modulo

*“Un’abitazione non è una casa  
a meno che non contenga cibo e  
calore per la mente oltre che  
per il corpo.”*

“A HOUSE IS NOT A HOME IF IT HASN'T GOT FOOD AND WARMTH FOR THE MIND AND THE BODY”

MARGARET FULLER



Madie  
sideboards

# Modulo

## PICCOLI E VERSATILI CONTENITORI

*Piccoli mobili contenitore o madie più grandi e capienti, sono elementi compositivi che armonizzano l'ambiente living, offrendo punti d'appoggio o utili spazi per riporre gli oggetti. Adattabili con versatilità ad ogni contesto arredativo, diventano il complemento ideale per il vivere moderno.*

## SMALL AN VERSATILE STORAGE UNITS

Small piece of furniture or bigger and roomy sideboards, are compositional elements which well harmonize the living atmosphere, offering support points or useful spaces to storage items. Adaptable with versatile aim to any furnishing space, they become an ideal option for the modern living.

Madia Sistema Modulo  
sideboard Modulo system



Madia Sistema Modulo  
sideboard Modulo system



**Madia Cloe**  
sideboard Cloe



**Madia Modular**  
sideboard Modular



**Madia Cloe**  
sideboard Cloe



**Madia Modular**  
sideboard Modular





Madia Sistema Modulo  
sideboard Modulo system



Madia Sistema Modulo  
sideboard Modulo system



Madia Sistema Modulo  
sideboard Modulo system



Madia Sistema Modulo  
sideboard Modulo system



Collezione  
collection

# Modulo

DETTAGLIO COMPOSIZIONI

*Modularità, dimensioni e finiture delle  
composizioni.*

COMPOSITION DETAIL

Modularity, dimensions and  
finishing of the compositions.



MODULO **01**

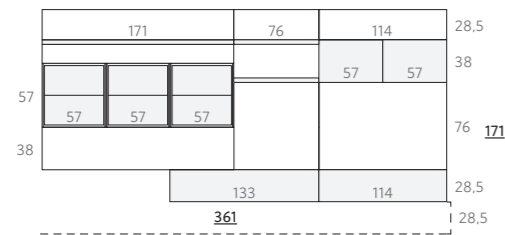

L. 361 H. 171 (199,5 DA TERRA) P. 45/38  
**SCOCHE E FRONTALI PENSILI:** TALPA LACCATO OPACO  
**MENSOLE:** TALPA LACCATO OPACO  
**SCOCHE VETRINE PENSILI:** ROVERE TERMOCOTTO  
**FRONTALI VETRINE PENSILI:** ALLUMINIO ANTRACITE E VETRO TRASPARENTE BRONZO  
**BOISERIE:** ROVERE TERMOCOTTO

W. 418 H. 133 (171 FROM FLOOR) D. 45/38  
**CASE AND FRONT HANGING UNITS:** TALPA MAT LACQUER  
**SHELIVING:** TALPA MAT LACQUER  
**CASE HANGING GLASS CABINETS:** ROVERE TERMOCOTTO  
**FRONT HANGING GLASS CABINETS:** ALLUMINUM ANTRACITE AND BROZE TRANSPARENT GLASS  
**PANELLING:** ROVERE TERMOCOTTO

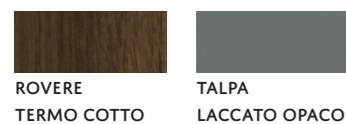

MODULO **01b**

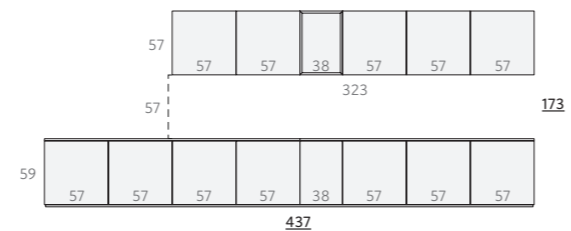

L. 437 H. 173 P. 45  
**FRONTALE MADIA:** ROVERE TERMO COTTO, TALPA LACCATO OPACO  
**SCOCCHA MADIA:** ROVERE TERMOCOTTO, TALPA LACCATO OPACO  
**ELEMENTO A GIORNO:** TALPA LACCATO OPACO

W. 437 H. 173 D. 45  
**FRONT SIDEBOARD:** ROVERE TERMOCOTTO, TALPA MAT LACQUER  
**CASE SIDEBOARD:** ROVERE TERMOCOTTO, TALPA MAT LACQUER  
**OPEN UNITS:** TALPA MAT LACQUER

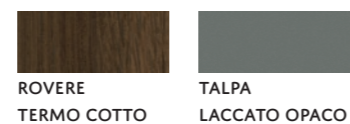

MODULO **02**

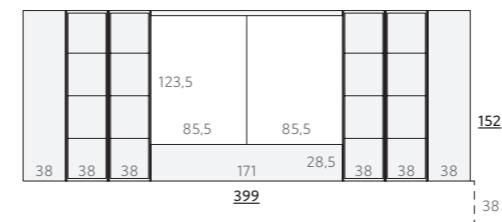

L. 399 H. 152 (190 DA TERRA) P. 38  
**SCOCHE E FRONTALI PENSILI:** ROVERE TERMOCOTTO  
**MENSOLA:** ROVERE TERMOCOTTO  
**SCOCHE VETRINE PENSILI:** ROVERE TERMOCOTTO, SCHIENE CENERE LACCATO OPACO  
**FRONTALI VETRINE PENSILI:** ALLUMINIO ANTRACITE E VETRO TRASPARENTE BRONZO  
**BOISERIE:** ROVERE TERMOCOTTO

W. 399 H. 152 (190 DA TERRA) D. 38  
**CASE AND FRONT HANGING UNITS:** ROVERE TERMOCOTTO  
**SHELIVING:** ROVERE TERMOCOTTO  
**CASE GLASS HANGING UNITS:** ROVERE TERMOCOTTO, BACKBOARDS CENERA MAT LACQUER  
**FRONT GLASS HANGING UNITS:** ALLUMINUM ANTRACITE AND BRONZE TRANSPARENT GLASS  
**PANELLING:** ROVERE TERMOCOTTO

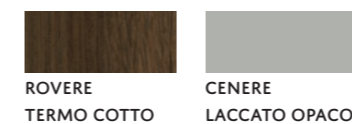

MODULO **03**

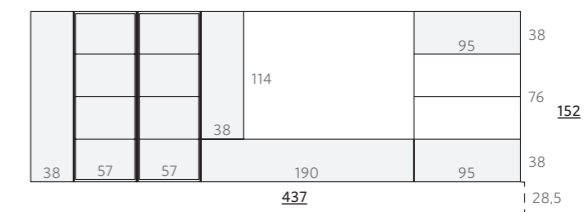

L. 437 H. 152 (180,5 DA TERRA) P. 45/38  
**FRONTALE PENSILI:** FRASSINO NATURALE, FANGO LACCATO OPACO  
**SCOCCHA PENSILI:** FRASSINO NATURALE, FANGO LACCATO OPACO  
**MENSOLE:** FANGO LACCATO OPACO  
**SCOCHE VETRINE PENSILI:** FRASSINO OSSIDATO NATURAL  
**FRONTALI VETRINE PENSILI:** ALLUMINIO ANTRACITE E VETRO TRASPARENTE BRONZO  
**BOISERIE:** FANGO LACCATO OPACO

W. 437 H. 152 (180,5 FROM FLOOR) D. 45/38  
**FRONT HANGING UNITS:** FRASSINO NATURAL, FANGO MAT LACQUER  
**SHELIVING:** FANGO MAT LACQUER  
**CASE GLASS HANGING UNITS:** FRASSINO OSSIDATO NATURAL  
**FRONT GLASS HANGING UNITS:** ALLUMINUM ANTRACITE AND BRONZE TRANSPARENT GLASS  
**PANELLING:** FANGO MAT LACQUER



PAG. 10-11



PAG. 18-19



PAG. 22-23



PAG. 32-33



MODULO **03b**

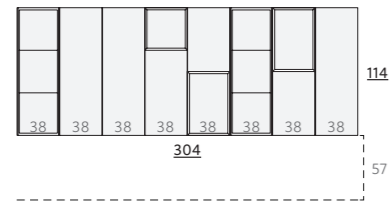

**L. 304 H. 114 (171 DA TERRA) P. 45/38**  
**FRONTALE PENSILI:** FRASSINO OSSIDATO NATURAL  
**SCOCCA PENSILI:** FRASSINO OSSIDATO NATURAL  
**ELEMENTI A GIORNO:** FANGO LACCATO OPACO  
**FRONTALI VETRINE PENSILI:** ALLUMINIO ANTRACITE E VETRO TRASPARENTE BRONZO

**W. 304 H. 114 (171 FROM FLOOR) P. 45/38**  
**FRONT HANGING UNITS:** FRASSINO OSSIDATO NATURAL  
**CASE HANGING UNITS:** FRASSINO OSSIDATO NATURAL  
**OPEN UNITS:** FANGO MAT LACQUER  
**FRONT GLASS HANGING UNITS:** ALLUMINUM ANTRACITE AND BRONZE TRANSPARENT GLASS



MODULO **04**

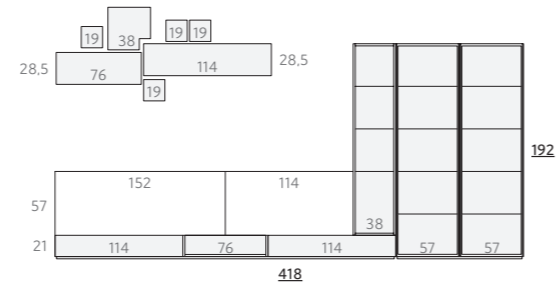

**L. 418 H. 192 P. 45/38/19**  
**SCOCHE E FRONTALI BASI, PENSILI E COLONNA GIORNO:** FUMO E CENERE LACCATO OPACO  
**SCOCHE VETRINE:** FUMO LACCATO OPACO  
**FRONTALI VETRINE:** ALLUMINIO ANTRACITE E VETRO TRASPARENTE BRONZO  
**BOISERIE:** FUMO LACCATO OPACO  
**ELEMENTI METALLO:** METALGREY OPACO, SCHIENE CENERE LACCATO OPACO

**W. 418 H. 192 P. 45/38/19**  
**CASE AND FRONT OPEN FLOOR/HANGING/VERTICAL UNITS:** FUMO AND CENERE MAT LACQUER  
**CASE GLASS CABINETS:** FUMO MAT LACQUER  
**FRONT GLASS CABINETS:** ALLUMINUM ANTRACITE AND BRONZE TRANSPARENT GLASS  
**PANELLING:** FUMO MAT LACQUER  
**MATAL UNITS:** MAT METALGREY, BACKBOARDS CENERE MAT LACQUER



MODULO **04b**

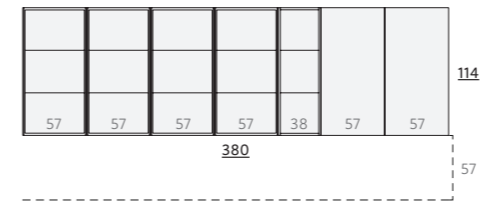

**L. 380 H. 114 (171 DA TERRA) P. 38**  
**FRONTALE PENSILI:** FUMO LACCATO OPACO  
**SCOCCA PENSILI:** FUMO LACCATO OPACO, CENERE LACCATO OPACO  
**FRONTALI VETRINE:** ALLUMINIO ANTRACITE VETRO TRASPARENTE BRONZO  
**ELEMENTI A GIORNO:** CENERE LACCATO OPACO

**W. 380 H. 114 (171 FROM FLOOR) D. 38**  
**FRONT HANGING UNITS:** FUMO MAT LACQUER, CENERE MAT LACQUER  
**FRONT GLASS CABINETS:** ALLUMINUM ANTRACITE AND BRONZE TRANSPARENT GLASS  
**OPEN UNITS:** CENERE MAT LACQUER

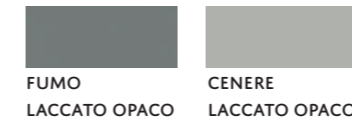

MODULO **05**

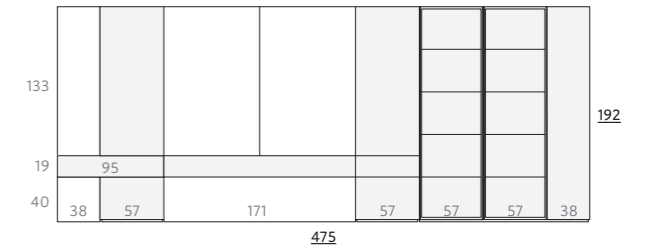

**L. 475 H. 192 P. 45/38**  
**SCOCHE E FRONTALI BASI:** CORDA LACCATO OPACO  
**SCOCHE VETRINE BASI:** FRASSINO OSSIDATO GREY  
**FRONTALI VETRINE BASI:** ALLUMINIO ANTRACITE E VETRO TRASPARENTE BRONZO  
**SCOCHE E FRONTALI PENSILI ORIZZONTALI:** FRASSINO OSSIDATO GREY  
**BOISERIE:** FRASSINO OSSIDATO GREY

**W. 475 H. 192 D. 45/38**  
**CASE AND FRONT FLOOR UNITS:** CORDA MAT LACQUER  
**CASE FLOOR GLASS CABINETS:** FRASSINO OSSIDATO GREY  
**FRONT FLOOR GLASS CABINETS:** ALLUMINUM ANTRACITE AND BRONZE TRANSPARENT GLASS  
**CASE AND FRONT HORIZONTAL HANGING UNITS:** FRASSINO OSSIDATO GREY  
**PANELLING:** FRASSINO OSSIDATO GREY



PAG. 40-41



PAG. 46-47



PAG. 50-51



PAG. 56-57





MODULO **06**

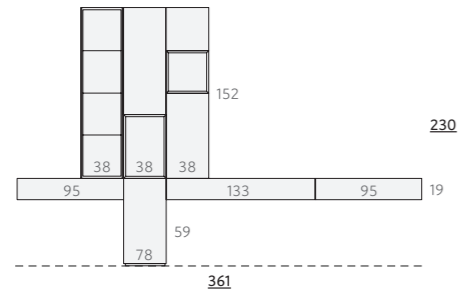

L. 361 H. 230 P. 45/38  
**SCOCHE E FRONTALI PENSILI ORIZZONTALI E PENSILI COLONNA:** SPAGO LACCATO OPACO  
**SCocca VETRINA PENSILE:** ASFALTO LACCATO OPACO  
**FRONTALI VETRINE PENSILI:** ALLUMINIO ANTRACITE E VETRO TRASPARENTE BRONZO  
**ELEMENTI A GIORNO:** FRASSINO OSSIDATO NATURAL

W.361 H. 230 D. 45/38  
**CASE AND FRONT HORIZONTAL HANGING UNITS AND HANGING VERTICAL UNITS:** SPAGO MAT LACQUER  
**CASE HANGING GLASS CABINETS:** ASFALTO MAT LACQUER  
**FRONT HANGING GLASS UNITS:** ALLUMINUM ANTRACITE AND BRONZE TRANSPARENT GLASS  
**OPEN UNITS:** FRASSINO OSSIDATO NATURAL



MODULO **06b**

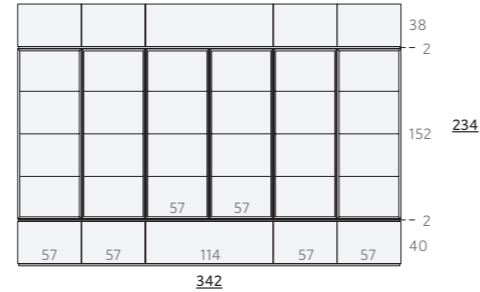

L. 342 H. 234 P. 38  
**SCOCHE E FRONTALI BASI E PENSILI ORIZZONTALI:** SPAGO LACCATO OPACO  
**SCOCHE VETRINE PENSILI:** FRASSINO OSSIDATO NATURAL  
**FRONTALI VETRINE PENSILI:** ALLUMINIO ANTRACITE E VETRO TRASPARENTE BRONZO  
**ELEMENTI A GIORNO:** SPAGO LACCATO OPACO

W. 342 H. 234 D. 38  
**CASE AND FRONT FLOOR/HORIZONTAL HANGING UNITS:** FRASSINO OSSIDATO NATURAL  
**FRONT GLASS HANGING UNITS:** ALLUMINUM ANTRACITE AND BRONZE TRANSPARENT GLASS  
**OPEN UNITS:** SPAGO MAT LACQUER



MODULO **07**

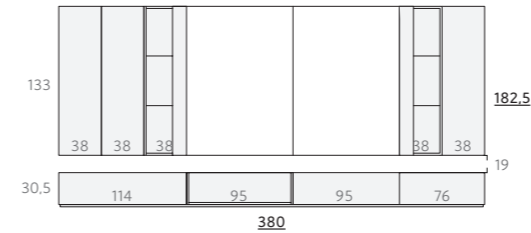

L. 380 H. 182,5 P. 53/38  
**SCOCHE E FRONTALI BASI ORIZZONTALI E PENSILI COLONNA:** ANTRACITE LACCATO OPACO  
**SCocca TERMINALI GIORNO E BASE A VASSOIO:** ECRÙ LACCATO OPACO  
**BOISERIE:** ANTRACITE LACCATO OPACO

W.380 H. 182,5 D. 53/38  
**CASE AND FRONT HORIZONTAL FLOOR UNITS AND VERTICAL HANGING UNITS:** ANTRACITE MAT LACQUER  
**CASE OPEN TERMINAL UNITS AND FLOOR TRAY UNIT:** ECRÙ MAT LACQUER  
**PANELLING:** ANTRACITE MAT LACQUER

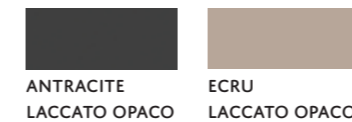

MODULO **08**

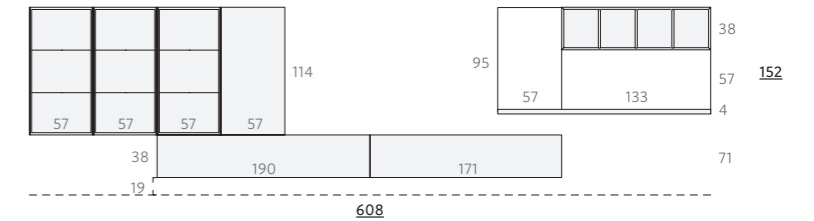

L. 608 H. 152 (171 DA TERRA) P. 45/38  
**FRONTALE PENSILI:** RESINA CEMENTO  
**SCOCHE PENSILI:** FANGO LACCATO OPACO  
**SCOCHE VETRINE PENSILI:** FRASSINO OSSIDATO NATURAL  
**FRONTALI VETRINE PENSILI:** ALLUMINIO ANTRACITE VETRO TRASPARENTE FUMÈ  
**ELEMENTO A GIORNO:** FANGO LACCATO OPACO  
**BOISERIE:** RESINA CEMENTO

W. 608 H. 152 (171 FROM FLOOR) D. 45/38  
**FRONT HANGING UNITS:** RESINA CEMENTO  
**CASE HANGING UNITS:** FANGO MAT LACQUER  
**CASE HANGING GLASS CABINETS:** FRASSINO OSSIDATO NATURAL  
**FRONT HANGING GLASS CABINETS:** ALLUMINUM ANTRACITE AND FUMÈ TRANSPARENT GLASS  
**OPEN UNITS:** FANGO MAT LACQUER  
**PANELLING:** RESINA CEMENTO

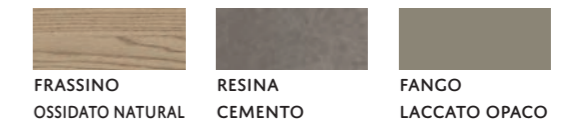

PAC. 68-69



PAC. 72-73



PAC. 82-83



PAC. 94-95



MODULO **08b**

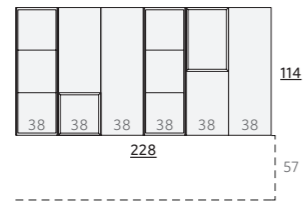

L. 228 H. 114 (171 DA TERRA) P. 45/38  
 SCOCHE E FRONTALI PENSILI: CENERE LACCATO OPACO  
 SCOCHE VETRINE PENSILI: FANGO LACCATO OPACO  
 FRONTALI VETRINE PENSILI: ALLUMINIO ANTRACITE E VETRO TRASPARENTE BRONZO  
 ELEMENTI A GIORNO: FANGO LACCATO OPACO

W. 228 H. 114 (171 FROM FLOOR) D. 45/38  
 CASE AND FRONT HNGING UNITS: CENERE MAT LACQUER  
 CASE HANGING GLASS CABINETS: FANGO MAT LACQUER  
 FRONT HANGING GLASS CABINETS: ALLUMINUM ANTRACITE AND BRONZE TRANSPARENT GLASS  
 OPEN UNITS: FANGO MAT LACQUER



MODULO **09**

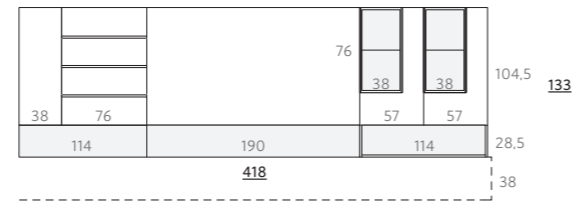

L. 418 H. 133 (171 DA TERRA) P. 45/38/28  
 FRONTALE E SCOCHE PENSILI ORIZZONTALI: CENERE LACCATO OPACO  
 SCOCHE VETRINE PENSILI E VASSOIO PENSILE: FRASSINO OSSIDATO BROWN  
 FRONTALI VETRINE PENSILI: ALLUMINIO ANTRACITE E VETRO TRASPARENTE BRONZO  
 BOISERIE: FRASSINO OSSIDATO BROWN E CENERE LACCATO OPACO  
 MENSOLE: VETRO TRASPARENTE BRONZO

W. 418 H. 133 (171 FROM FLOOR)  
 FRONT AND CASE HORIZONTAL HANGING UNITS: CENERE MAT LACQUER  
 CASE HANGING GLASS CABINETS AND HANGING TRAY: FRASSINO OSSIDATO BROWN  
 FRONT HANGING GLASS CABINETS: ALLUMINUM ANTRACITE AND BRONZE TRANSPARENT GLASS  
 PANELLING: FRASSINO OSSIDATO BROWN AND CENERE MAT LACQUER  
 SHELVING: BRONZE TRANSPARENT GLASS



MODULO **10**

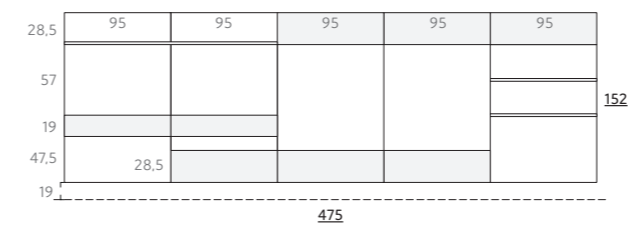

L. 475 H. 152 (171 DA TERRA) P. 45/38  
 FRONTALE PENSILI: FUMO LACCATO OPACO  
 SCOCCA PENSILI: FUMO LACCATO OPACO  
 MENSOLE: FUMO LACCATO OPACO  
 BOISERIE: CENERE LACCATO OPACO

W. 475 H. 152 (171 FROM FLOOR) D. 45/38  
 FRONT HANGING UNITS: FUMO MAT LACQUER  
 CASE HANGING UNITS: FUMO MAT LACQUER  
 SHELVING: FUMO MAT LACQUER  
 PANELLING: CENERE MAT LACQUER



PAG. 98-99



PAG. 104-105



PAG. 112-113





# Basi

## FLOOR UNITS

MODULARITÀ APPLICATA  
ALLE BASI ORIZZONTALI A TERRA  
O SOSPESE

MODULARITY APPLIED TO THE  
HORIZONTAL FLOOR/HANGING  
UNITS

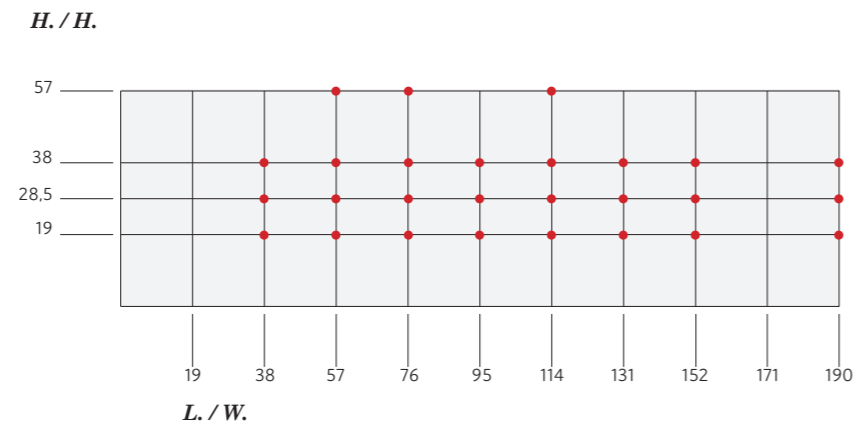

NOTA: PER H. BASI ORIZZONTALI + 2 CM. DI ZOCCOLO  
NOTICE: FOR HEIGHT HORIZONTAL FLOOR UNITS +2 CM PLINTH

# Librerie e pensili

## BOOKCASE AND HANGING UNITS

MODULARITÀ APPLICATA ALLE  
COLONNE VERTICALI A TERRA O  
SOSPESE

MODULARITY APPLIED TO THE  
VERTICAL FLOOR/HANGING UNITS

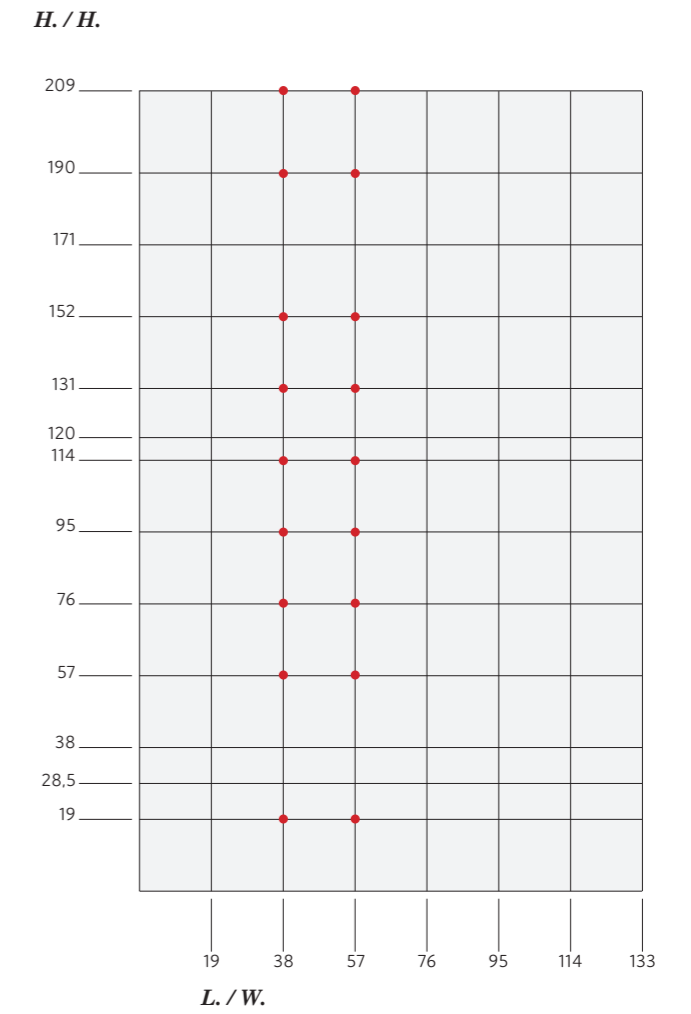

NOTA: H. BASI COLONNA VERTICALI + 2 CM. DI ZOCCOLO  
NOTICE: H. VERTICAL FLOOR UNITS +2CM PLINTH

Collezione  
collection

# Modulo

FINITURE

*Elenco finiture disponibili.*

FINISHING

List of the available finishing.



# Essenze

## WOODEN FINISHING

ROVERE TERMOCOTTO



ROVERE TERMOCOTTO

ROVERE TINTO

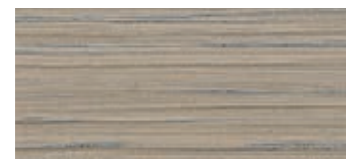

*cenere*



*tabacco*

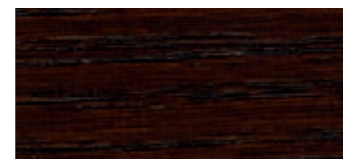

*moro*

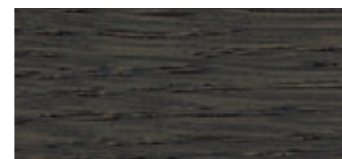

*grigio*



*rovere tavolato* \_ Rovere tavolato  
DISPONIBILE SOLO PER MENSOLE E TOP  
AVAILABLE ONLY FOR THE SHELVES AND TOP ITEMS

VARNISHED OAK

FRASSINO OSSIDATO



*natural*



*grey*



*brown*



*mud*

FRASSINO OSSIDATO

# Resine

## RESINS

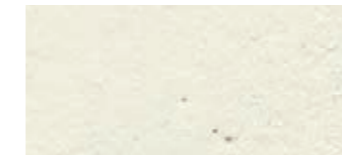

*bianco 01*

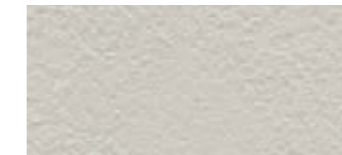

*tortora 04*

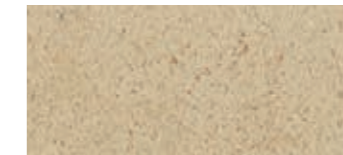

*sabbia 02*

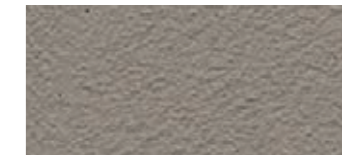

*visone 07*



*cemento 06*



*fumo 08*

# Specchi

## MIRRORS



*chiaro*



*bronzo*

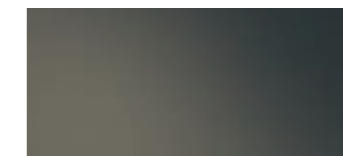

*fumè*



*bronzo acidato* \_ bronzo acidato



*acidato ice* \_ acidato ice

# Laccati

## LACQUERS

### FINITURE PERSONALIZZABILI NEI COLORI LACCATO

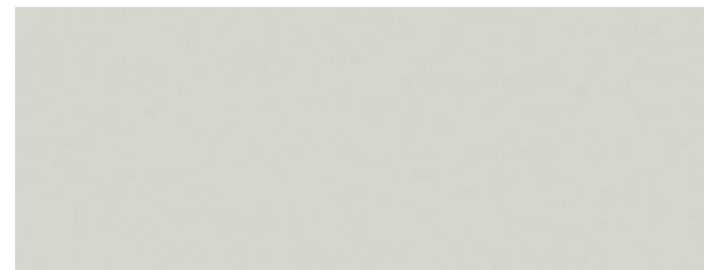

*laccati opachi/lucidi* \_ mat/high gloss lacquer

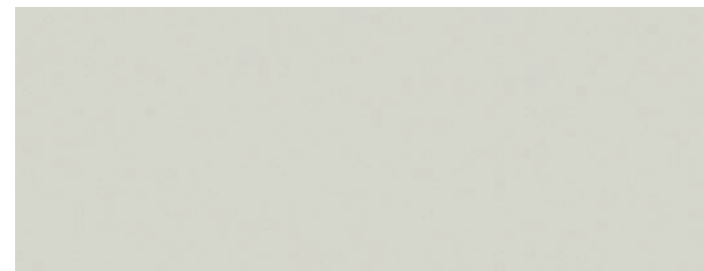

*vetro laccato opaco/lucido* \_ mat/high gloss lacquered glass

### LACCATI SPECIALI

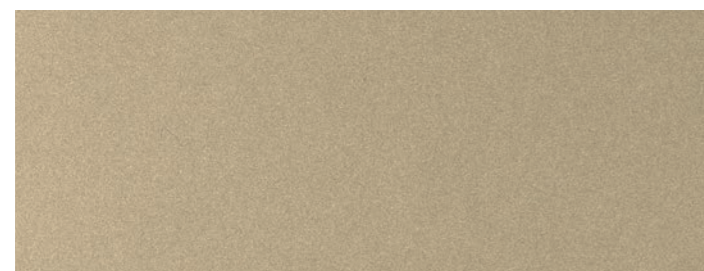

*champagne metal* \_ champagne metal

### CUSTOM FINISHING FOR LACQUERS

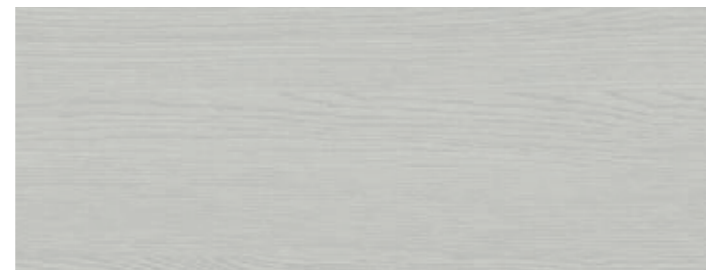

*frassino opaco* \_ mat ash

### SPECIAL LACQUERS

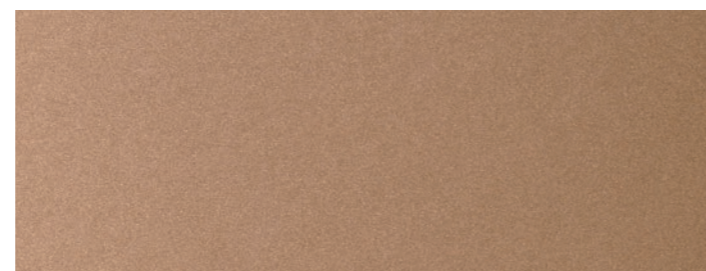

*rame metal* \_ rame metal



*124 bianco puro*



*101 panna*

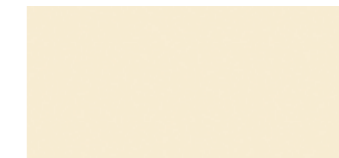

*127 burro*

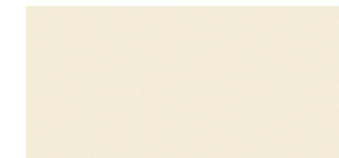

*447 vaniglia*



*448 platino*



*102 sahara*

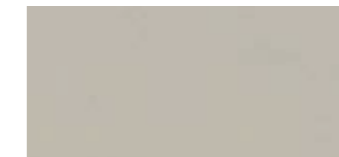

*442 corda*



*449 canapa*



*103 lino*

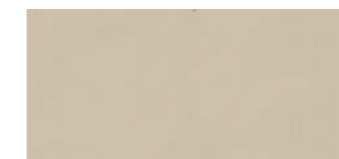

*446 conchiglia*



*445 ecrù*



*439 spago*

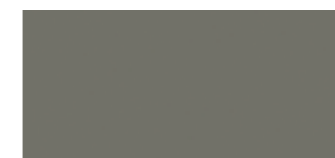

*450 talpa*



*441 fango*

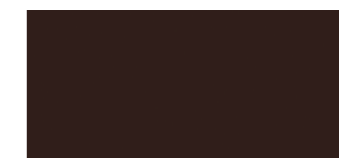

*125 moka*



*130 cenere*



*438 fumo*



*105 antracite*



*451 asfalto*



*440 salvia*



*111 arancio*



*116 rosso rubino*



*114 melanzana*



*434 lilla*



*437 avio*



*452 oltremare*



*Vetro lucido effetto marmo*  
HIGH GLOSS GLASS MARBLE EFFECT



*Carrara* \_ Carrara



*Calacatta* \_ Calacatta



*Emperador* \_ Emperador



*Sahara Noir* \_ Sahara Noir

*designer:*

S.T. Veneran / Luciano Trevisiol

*ad:*

Marco Bortolin

*graphic design:*

www.oecusdesign.it

*photo 3D:*

www.oecusdesign.it

*prepress:*

GM Studio 1 (VR)

*print:*

Grafiche Baggio

*Novembre 2020*



**Veneran mobili srl**

Via Nazionale 34/38 - 31050 Veduggio TV - Tel. +39 0423 7770 - Fax +39 0423 777177 - veneran@veneran.com



